



Garun Series

80 pieces battery cabinet

UPBPTA2422BX-AZ01B
UPBPTA2422CX-AZ01B

Installation and battery connection for 80 pieces EBM,
sequence (20+20) x 2



Thank you for purchasing our products!

Please read this manual before using the product.



Focusing on quality at competitive prices, **nJoy** designs consumer products for a better and enjoyable way into the digital world.

The battery pack is a product that works only with an UPS. The battery pack will provide or extend the backup time of your UPS.

Garun Series models that are compatible with this EBM model:

15K VA → Garun 15KL

20K VA → Garun 20KL

30K VA → Garun 30KL

40K VA → Garun 40KL

60K VA → Garun 60KL

80K VA → Garun 80KL

1 Installation and battery connection in sequence (20+20)x2

Step 1

Turn the cabinet's switch to OFF. Remove the top lid by sliding it upwards.

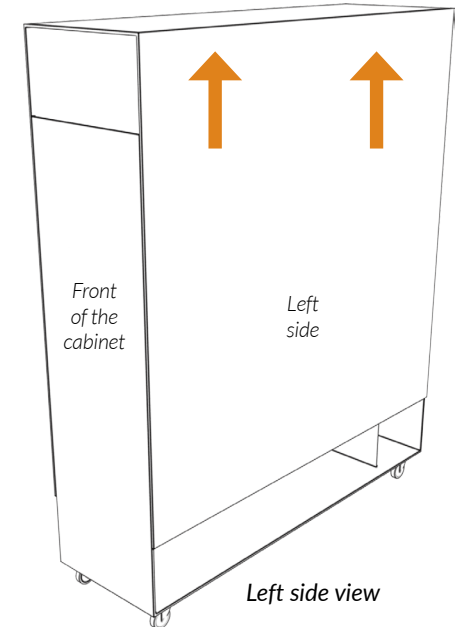

Left side view

Step 2

Remove the left-side pieces that help keep the batteries in place.

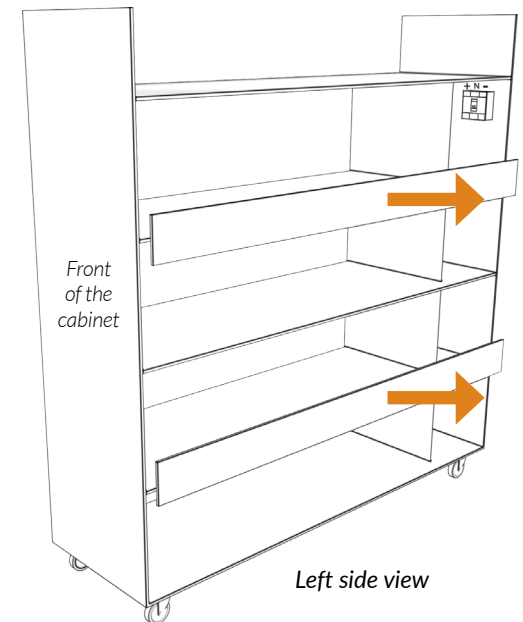

Left side view

Step 3

Find the first tray, second tray, third tray and fourth tray on which to place the batteries, as shown on the side picture. Place the batteries starting with the first tray and continue up on the respective trays in a total maximum of 80 pcs.

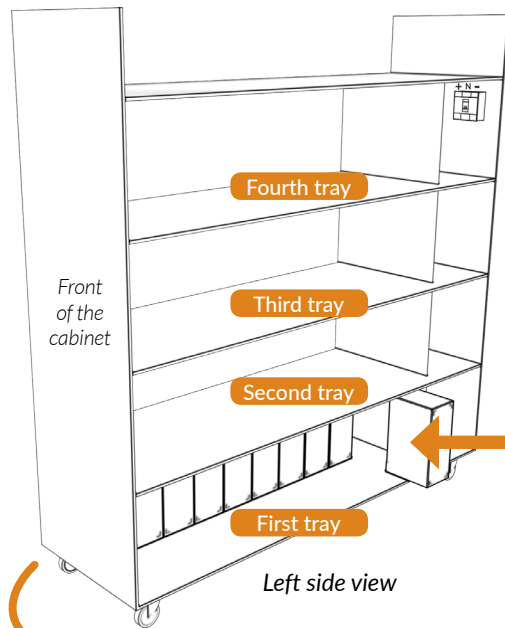

Step 4

Looking at the front of the cabinet, the batteries will be placed upwards:

4.1 Through the right side, the batteries will be placed vertically, with the terminals facing outwards and down.

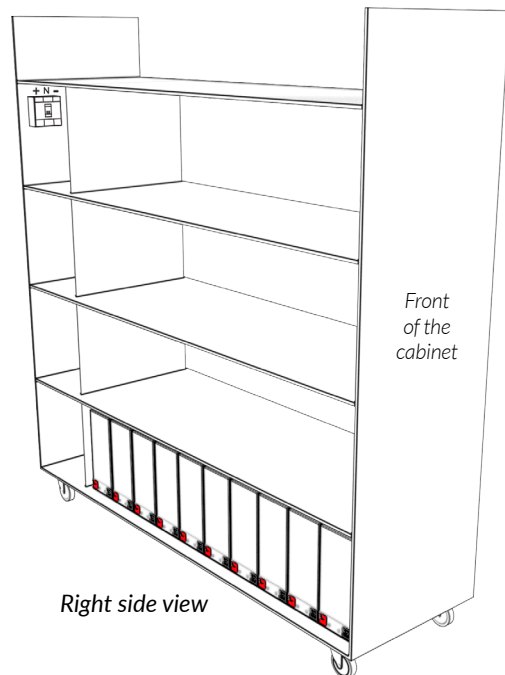

4.2 On the same tray, through the left side, place another set of 10 batteries, vertically, with the terminals facing outwards and down.

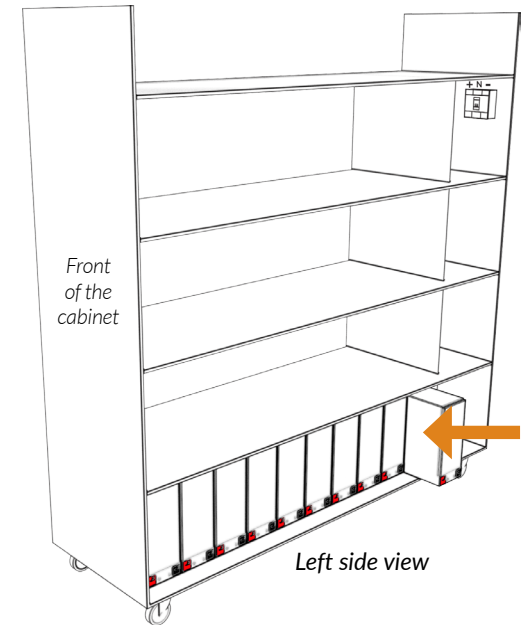

4.3 Start placing the batteries on the second tray, through the right side, vertically, with the terminals facing outwards and up.

4.4 Continue placing the batteries on the same tray, through the left side, vertically, with the terminals facing outwards and up.

4.5 Placement on the next two trays is similar to the first two.

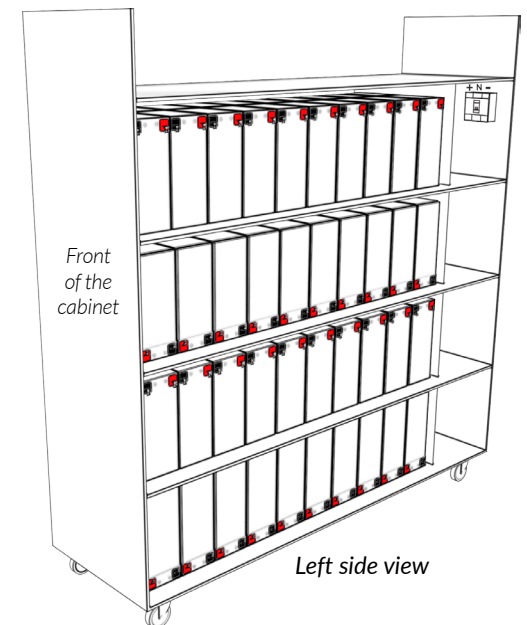

Step 5

Insert back the pieces that hold the batteries in place.

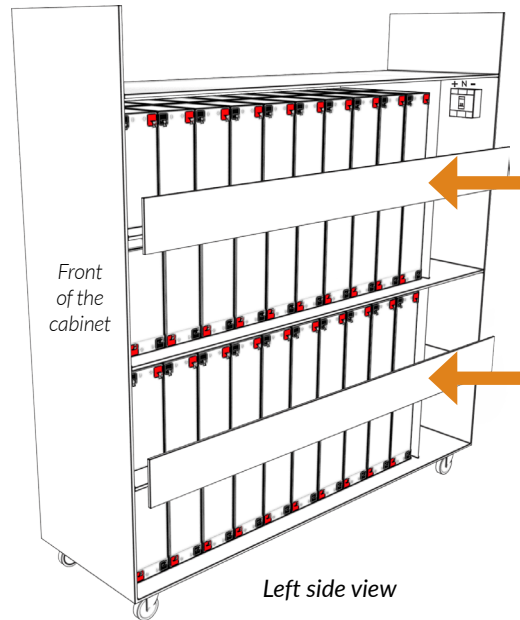

Step 6

Find the connection cables. Each cable is numbered from 1 to 6, with the following quantities for each cable type:

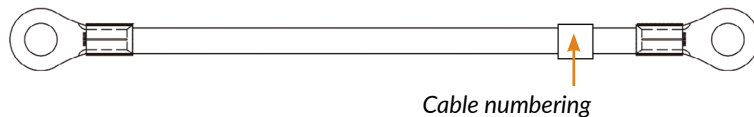

Nr.	Description	Pieces	Cable numbering
1	#10 AWG cable (Black)	72	1
2	#10 AWG cable (Black) - bound to the cabinet	2	2 (BAT-)
3	#10 AWG cable (Red) - bound to the cabinet	2	3 (BAT+)
4	#10 AWG cable (Black)	2	4
5	#10 AWG cable (Blue) - bound to the cabinet	4	5 (N)
6	#10 AWG cable (Black)	2	6

Step 7

The following connections are made (according to the diagram on pages 8-9).

7.1 Using the no.1 cables connect in series all the adjacent batteries, the (-, black) terminal of a battery connecting to the (+, red) terminal of the battery immediately adjacent.

7.2 Using the two black cable no. 2 from the cabinet (-, black) connect the free (-, black) terminals of the batteries on the right side of the cabinet on the second and fourth tray, as in the diagram.

7.3 Using the two red cable no. 3 from the cabinet (+, red), connect the free (+, red) terminals of the batteries on the left side of the cabinet on second and fourth tray, as shown.

7.4 Using black cables no. 4 connect the free battery terminals located on the first and second tray of the cabinet on the left (with one of cables), respectively on the same trays but on the right side with the other cable, as in the scheme.

7.5 Using the blue cables no. 5 from the cabinet connect to the free terminals of the batteries (+, red terminal) on the first and third tray of the cabinet, on the right side (with two of the cables). On the left side on the cabinet connect the other two blue cables from the cabinet to the free terminals of the batteries on the first and third tray (-, black terminal) as in the diagram.

7.6 Using black cables no. 6 connect the free terminals of the batteries located on the third and fourth tray of the cabinet on the left (with one of cables), respectively on the same trays but on the right side with the other cable, as in the scheme.

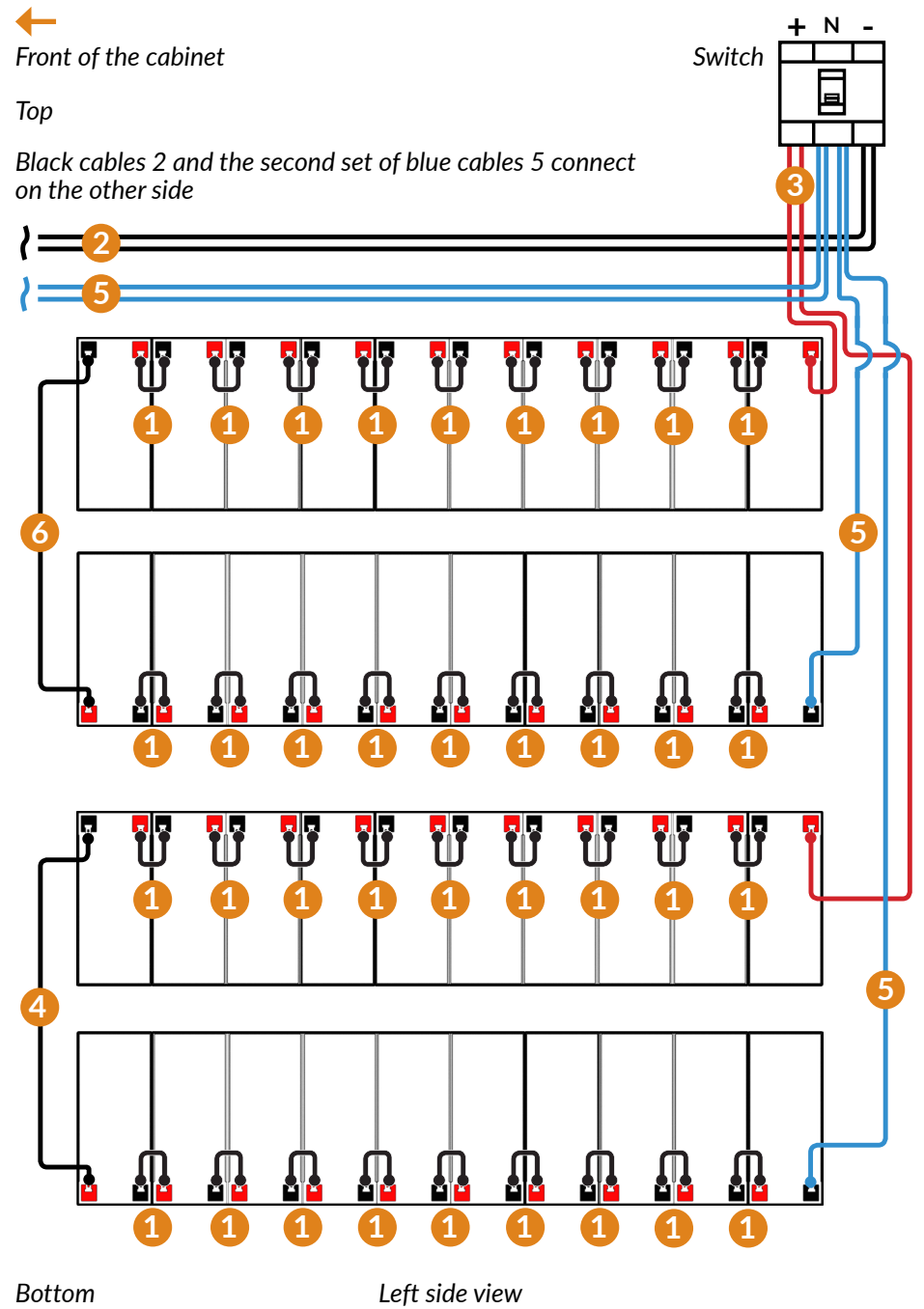
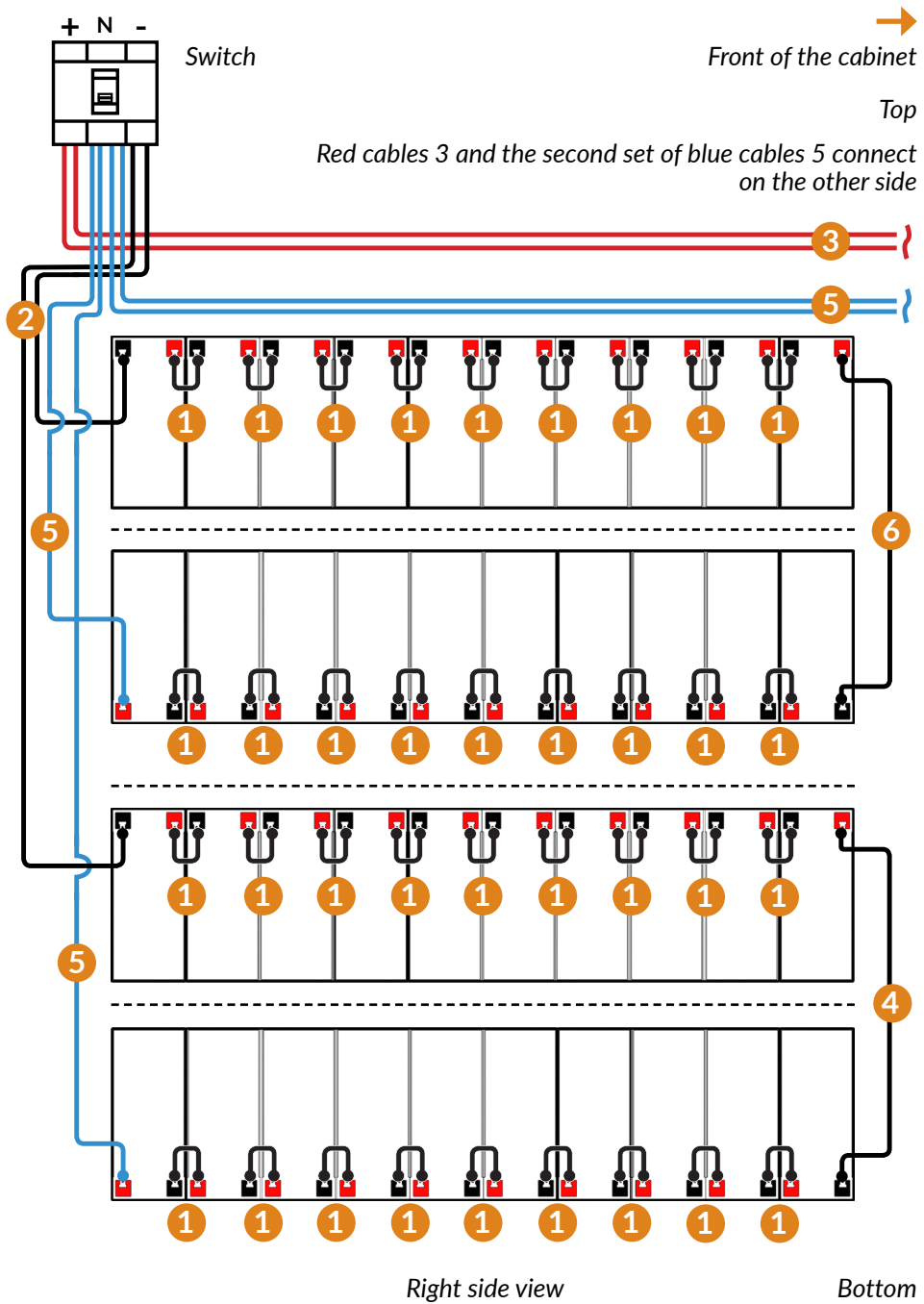

Step 8

Make sure the cables are correctly connected on each side, then slide the top lid back on and secure it in place.

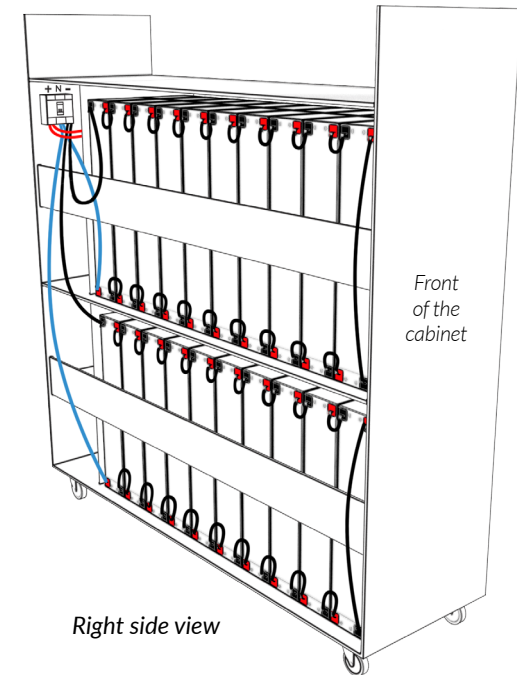
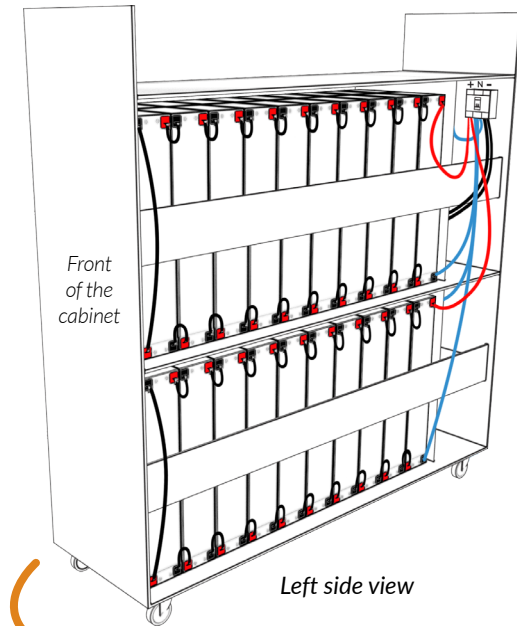

Step 9

Switch the power to ON. The EBM is now active and functioning.

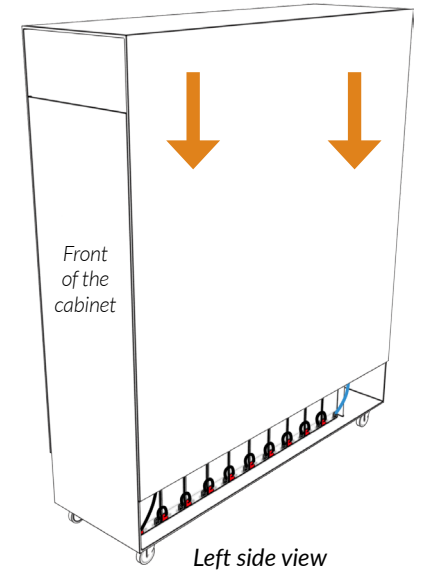

NOTE!

A If fewer batteries are used in the cabinet, in one of the configurations (16 + 16) x2, (17 + 17) x2, (18 + 18) x2, (19 + 19) x2, batteries will be appropriately distributed, and the connections will be made in a similar way, respecting the principle of symmetry and balance. The blue cable from the cabinet (cable no. 5) will be connected to a string with an equal number of batteries connected in series (16, 17 ... 19).

Example:

For a configuration (16 + 16) x2:

- 10 + 10 batteries will be on the first tray (10 on the right side, 10 on the left side);
- on the second tray 6 + 6;
- on the third tray 6 + 6;
- on the fourth tray 10 + 10.

B If you want to use only one string of batteries (16 + 16) x1, (17 + 17) x1, (18 + 18) x1, (19 + 19) x1, (20 + 20) x1, please populate only the first two trays with batteries and follow the same steps for connecting the cables. You will be using only one black cable, one red cable and two blue cables connected to the battery cabinet.

 Memo

.....

.....

.....

.....

.....

.....

.....

.....

.....

.....

.....

.....

.....

.....

.....

.....

.....

.....

.....

.....

.....

.....

.....



Disposal of Old Electrical & Electronic Equipment

(Applicable in the European Union and other European countries with separate collection systems)

This symbol on the product or on its packaging indicates that this product shall not be treated as household waste.

Instead it shall be handed over to the applicable collection point for the recycling of electrical and electronic equipment.

By ensuring this product is disposed of correctly, you will help prevent potential negative consequences for the environment and human health, which could otherwise be caused by inappropriate waste handling of this product.

The recycling of materials will help to conserve natural resources.

