

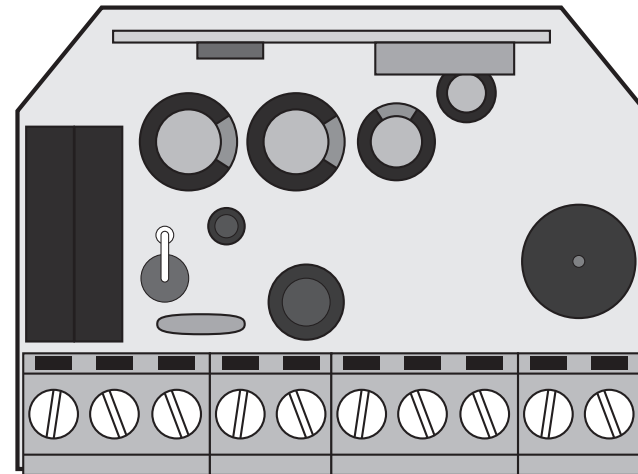

# MC70 EVO

## USER/INSTALLER MANUAL







# 00. CONTENT

## INDEX

<b>01. SAFETY INSTRUCTIONS</b>	<b>1B</b>
<b>02. CONNECTIONS SCHEME</b>	
CONNECTION TO A DOUBLE WALL SWITCH	4A
CONNECTION TO A SINGLE WALL SWITCH	4B
CONNECTION OF SEVERAL MC70 EVO CONTROL BOARDS - MASTER FUNCTION	5A
<b>03. THE CONTROL BOARD</b>	
TECHNICAL CHARACTERISTICS	6A
CONNECTOR'S DESCRIPTION	6A
<b>04. PROGRAMMING</b>	
PRE-PROGRAMMING INFORMATION	6B
REMOTE CONTROLS PROGRAMMING	7A
PROGRAMMING REMOTE CONTROLS THROUGH A ALREADY PROGRAMMED ONE	7A
PROGRAMMING OF REMOTE CONTROLS THROUGH SWITCH	7B
DELETE REMOTE CONTROLS	8A
CHANGE THE MOTOR DIRECTION	8B

# 01. SAFETY INSTRUCTIONS

## ATTENTION:

	This product is certified in accordance with European Community (EC) safety standards.
	This product complies with Directive 2011/65/EU of the European Parliament and of the Council, of 8 June 2011, on the restriction of the use of certain hazardous substances in electrical and electronic equipment and with Delegated Directive (EU) 2015/863 from Commission.
	(Applicable in countries with recycling systems). This marking on the product or literature indicates that the product and electronic accessories (eg. Charger, USB cable, electronic material, controls, etc.) should not be disposed of as other household waste at the end of its useful life. To avoid possible harm to the environment or human health resulting from the uncontrolled disposal of waste, separate these items from other types of waste and recycle them responsibly to promote the sustainable reuse of material resources. Home users should contact the dealer where they purchased this product or the National Environment Agency for details on where and how they can take these items for environmentally safe recycling. Business users should contact their vendor and check the terms and conditions of the purchase agreement. This product and its electronic accessories should not be mixed with other commercial waste.
	
	This marking indicates that the product and electronic accessories (eg. charger, USB cable, electronic material, controls, etc.) are susceptible to electric shock by direct or indirect contact with electricity. Be cautious when handling the product and observe all safety procedures in this manual.

# 01. SAFETY INSTRUCTIONS

## **GENERAL WARNINGS**

- This manual contains very important safety and usage information, very important. Read all instructions carefully before beginning the installation/usage procedures and keep this manual in a safe place that it can be consulted whenever necessary.
- This product is intended for use only as described in this manual. Any other enforcement or operation that is not mentioned is expressly prohibited, as it may damage the product and put people at risk causing serious injuries.
- This manual is intended firstly for specialized technicians, and does not invalidate the user's responsibility to read the "User Norms" section in order to ensure the correct functioning of the product.
- The installation and repair of this product may be done by qualified and specialized technicians, to assure every procedure are carried out in accordance with applicable rules and norms. Nonprofessional and inexperienced users are expressly prohibited of taking any action, unless explicitly requested by specialized technicians to do so.
- Installations must be frequently inspected for unbalance and the wear signals of the cables, springs, hinges, wheels, supports and other mechanical assembly parts.
- Do not use the product if it is necessary repair or adjustment is required.
- When performing maintenance, cleaning and replacement of parts, the product must be disconnected from power supply. Also including any operation that requires opening the product cover.
- The use, cleaning and maintenance of this product may be carried out by any persons aged eight years old and over and persons whose physical, sensorial or mental capacities are lower, or by persons without any knowledge of the product, provided that these are supervision and instructions given by persons with experienced in terms of usage of the product in a safe manner and who understands the risks and dangers involved.

- Children shouldn't play with the product or opening devices to avoid the motorized door or gate from being triggered involuntarily.

## **WARNINGS FOR TECHNICIANS**

- Before beginning the installation procedures, make sure that you have all the devices and materials necessary to complete the installation of the product.
- You should note your Protection Index (IP) and operating temperature to ensure that is suitable for the installation site.
- Provide the manual of the product to the user and let them know how to handle it in an emergency.
- If the automatism is installed on a gate with a pedestrian door, a door locking mechanism must be installed while the gate is in motion.
- Do not install the product "upside down" or supported by elements do not support its weight. If necessary, add brackets at strategic points to ensure the safety of the automatism.
- Do not install the product in explosive site.
- Safety devices must protect the possible crushing, cutting, transport and danger areas of the motorized door or gate.
- Verify that the elements to be automated (gates, door, windows, blinds, etc.) are in perfect function, aligned and level. Also verify if the necessary mechanical stops are in the appropriate places.
- The central must be installed on a safe place of any fluid (rain, moisture, etc.), dust and pests.
- You must route the various electrical cables through protective tubes, to protect them against mechanical exertions, essentially on the power supply cable. Please note that all the cables must enter the central from the bottom.
- If the automatism is to be installed at a height of more than 2,5m from the ground or other level of access, the minimum safety and health requirements for the use of work equipment workers at the work of Directive 2009/104/CE of European Parliament and of the Council of 16 September 2009.

# 01. SAFETY INSTRUCTIONS

- Attach the permanent label for the manual release as close as possible to the release mechanism.
- Disconnect means, such as a switch or circuit breaker on the electrical panel, must be provided on the product's fixed power supply leads in accordance with the installation rules.
- If the product to be installed requires power supply of 230Vac or 110Vac, ensure that connection is to an electrical panel with ground connection.
- The product is only powered by low voltage safety with central (only at 24V motors)

## WARNINGS FOR USERS

- Keep this manual in a safe place to be consulted whenever necessary.
- If the product has contact with fluids without being prepared, it must immediately disconnect from the power supply to avoid short circuits, and consult a specialized technician.
- Ensure that technician has provided you the product manual and informed you how to handle the product in an emergency.
- If the system requires any repair or modification, unlock the automatism, turn off the power and do not use it until all safety conditions have been met.
- In the event of tripping of circuits breakers or fuse failure, locate the malfunction and solve it before resetting the circuit breaker or replacing the fuse. If the malfunction is not repairable by consult this manual, contact a technician.
- Keep the operation area of the motorized gate free while the gate is in motion, and do not create strength to the gate movement.
- Do not perform any operation on mechanical elements or hinges if the product is in motion.

## RESPONSABILITY

- Supplier disclaims any liability if:
  - Product failure or deformation result from improper installation use or maintenance!
  - Safety norms are not followed in the installation, use and maintenance of the product.
  - Instructions in this manual are not followed.
  - Damaged is caused by unauthorized modifications
  - In these cases, the warranty is voided.

### **MOTORLINE ELECTROCELOS SA.**

Travessa do Sobreiro, nº29  
4755-474 Rio Côvo (Santa Eugénia)  
Barcelos, Portugal

## SYMBOLS LEGEND:



• Important safety notices



• Useful information



• Programming information



• Potentiometer information



• Connectors information



• Buttons information

## 02. CONNECTIONS SCHEME

### CONNECTION TO A DOUBLE WALL SWITCH

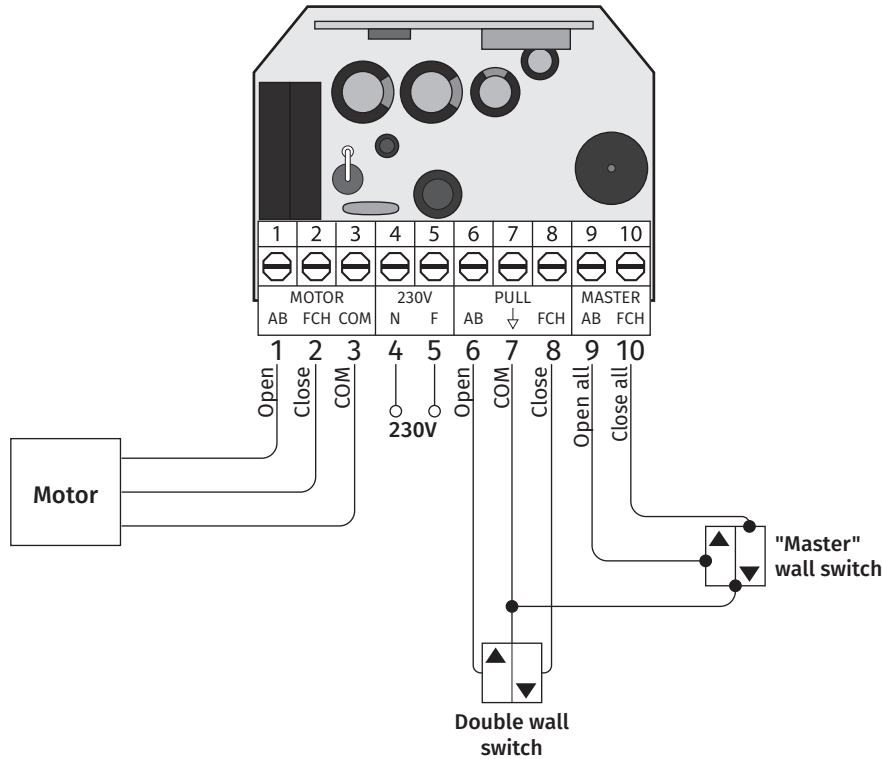

**i** All wall switches (local or master) are pushbuttons.

## 02. CONNECTIONS SCHEME

### CONNECTION TO A SINGLE WALL SWITCH

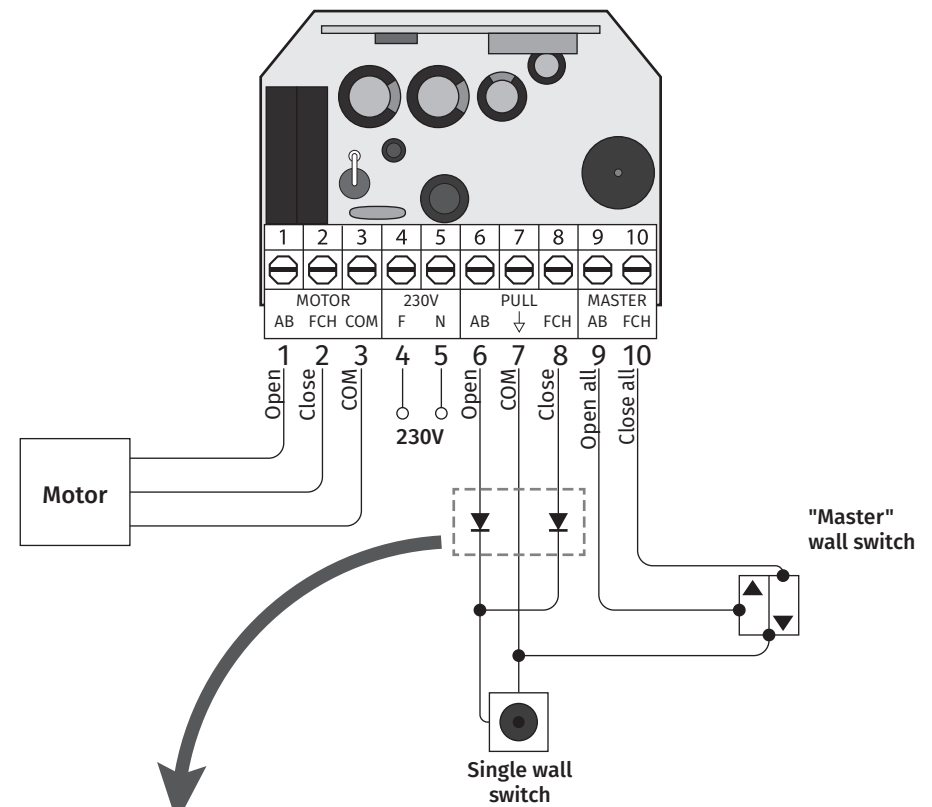

**!** To use a single push button simultaneously with "Master" push buttons, it is necessary to place diodes on the inputs of the local button.

**i** All wall switches (local or master) are push buttons.

## 02. CONNECTIONS SCHEME

### CONNECTION OF SEVERAL MC70 EVO CONTROL BOARDS - MASTER FUNCTION



The MC70 EVO control board MASTER function allows to connect and control several MC70 EVO control boards in the same wall switch (MASTER switch). In this way, whenever a Master switch button is pressed, all the interconnected control boards send a impulse to the motors to start the maneuver at the same time.

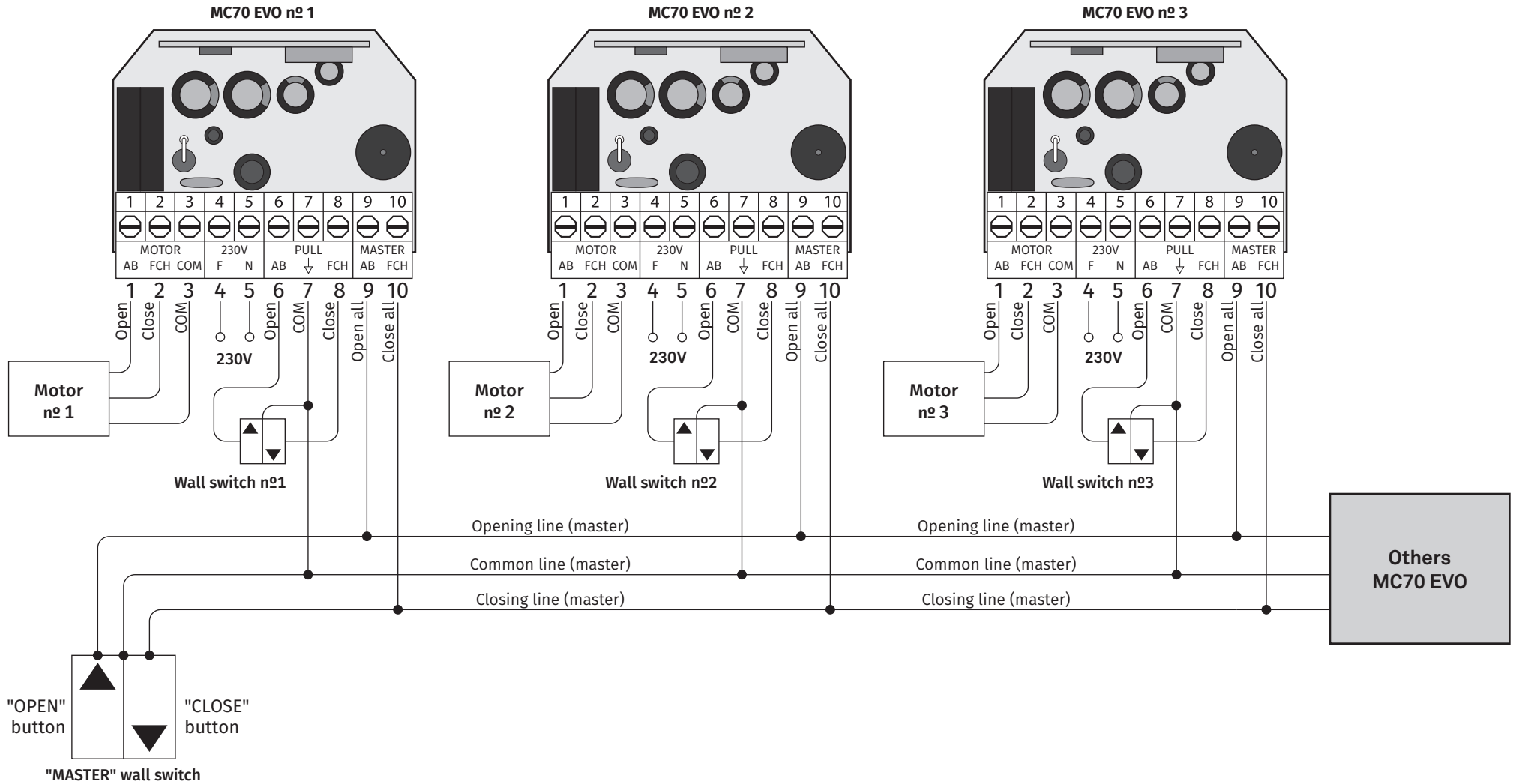

## 03. THE CONTROL BOARD

### TECHNICAL CHARACTERISTICS

This control board was developed to control TUB/Rolling motors. Its small size allows it to be installed in junction boxes, existing behind electrical switches (push buttons). It has 2 inputs for 1 or 2 buttons, one for local control and the other for centralized control, interconnecting several MC70 EVO control boards in the same push button (MASTER switch).

It allows operation with remote controls through 1 or 3 buttons, and all programming is done remotely, with only access to the power supply or a pushbutton needed to program the 1st remote control.

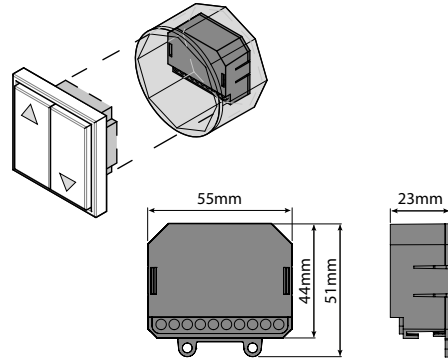

• Power Supply	230Vac 50-60Hz
• Motor's output	230Vac; 750W Max
• Built-in radio receiver	433,92 MHz
• Working temperature	-20°C to 70°C
• Nº of channels	120 remote controls
• Code type	Rolling Code
• Protection degree	IP44
• Fixed maximum working time per maneuver	4 min
• Control board measurements with box	56x44x23mm
• Box material	ABS

### CONNECTOR'S DESCRIPTION

CN1	01 • Motor output - OPENING
	02 • Motor output - COMMON
	03 • Motor output - CLOSING
	04 • 230V power supply (phase)
	05 • 230V power supply (neutral)
	06 • Wall switch connection - OPENING (NA)
	07 • Wall switch connection - COMMON
	08 • Wall switch connection - CLOSING (NA)
	09 • Wall switch connection - MASTER - OPENING (NA)
	10 • Wall switch connection - MASTER - CLOSING (NA)
<b>Attention: The MASTER switch connects the common wire in the 07 connector</b>	

## 04. PROGRAMMING

### PRE-PROGRAMMING INFORMATION

#### • REMOTE CONTROL PROGRAMMING TYPE

The control board allows the programming of two operating modes in remote controls: 1 button or 3 buttons.

<b>1 BUTTON</b>	You can program any button on the remote, which will send all orders to the control board. Example: Open - Stop - Close - Stop -Open (...)
<b>3 BUTTONS</b>	The programmed remote control will work with the buttons: <b>OPEN   CLOSE   STOP</b> . Each button will send a different order to the control board.

To know the buttons OPEN, STOP and CLOSE of the various remote controls, check the following schemes:

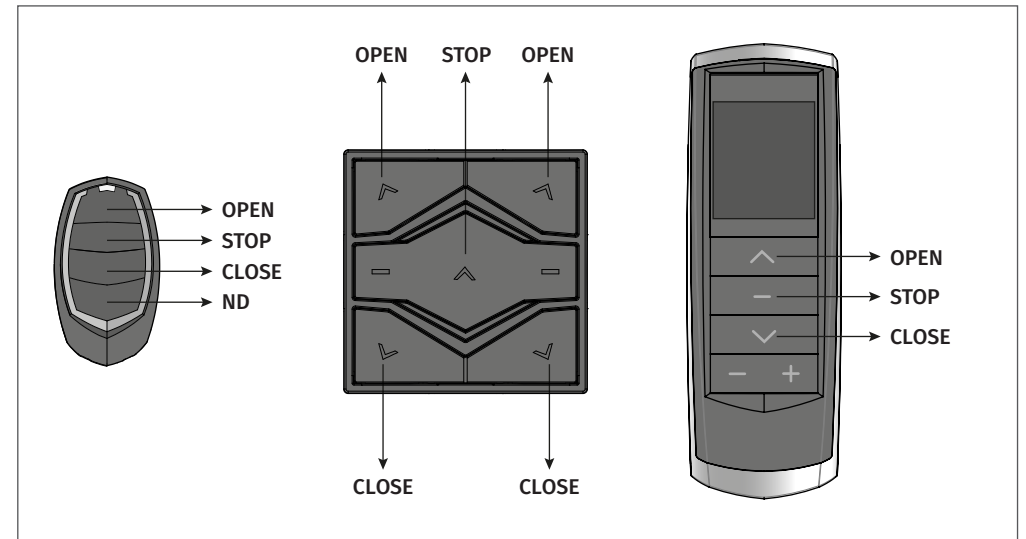

#### • WALL SWITCH

The control board allows the connection of pressure switches with one or two buttons. To start a maneuver, just do a simple 1 second pulse at the desired button.

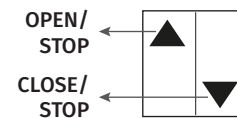

##### DOUBLE SWITCH

It has two buttons, one for opening and one for closing.  
During opening or closing maneuver, a click on the contrary button to the motor movement will stop this maneuver.

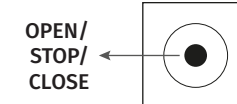

##### SINGLE SWITCH

It has one button, one for opening and one for closing.  
Clicking the button during opening/closing will stop motor movement.

## 04. PROGRAMMING

### REMOTE CONTROLS PROGRAMMING

This control board only allows programming MOTORLINE rolling code remote controls by a maximum of 120 remote controls. When programming the 121th remote control, the control board emits 1 beep to signal that the memory is full.

It is possible to program the first remote control through the control board power supply or via a push button. When you have an remote control already programmed, you can use it to open the memory of the control board at distance and program new remote controls.

#### **Program new remote control (3 buttons):**

- 01** • Press and hold the OPEN button of the remote control you want to program.
- 02** • Connect the control board to a 230V power supply.
- 03** • Keep the OPEN button pressed for 10 seconds, during which the control board emits 5 slow beeps.
- 04** • After 10 seconds, the control board emits 3 quick beeps confirming the programming success. Release the remote control button to finish programming the 3 buttons.
- 05** • If desired, you can add more remote controls for 10 seconds. If you press an already programmed remote control, you will hear long, fast beeps.
- 06** • After 10 seconds without any activity, the programming exits, signaled by 3 beeps.

#### **Program a new remote control (1 button):**

- 01** • Press and hold the OPEN button of the remote control you want to program.
- 02** • Connect the control board to a 230V power supply.
- 03** • Keep the OPEN button pressed for 10 seconds, during which the control board emits 5 slow beeps.
- 04** • After these 10 seconds, the control board emits 3 quick beeps.
- 05** • Keep the OPEN button pressed for another 6 seconds, during which the control board emits 3 slow beeps.
- 06** • After the total 16 seconds (10+6), the control board emits 3 quick beeps confirming the programming success.
- 07** • If desired, you can add more remote controls for 10 seconds. If you press an already programmed remote control, you will hear long, fast beeps.
- 08** • After 25 seconds without any activity, the programming exits, signaled by 3 beeps.

### PROGRAMMING REMOTE CONTROLS THROUGH A ALREADY PROGRAMMED ONE

#### **Program a new remote control (3-button) through another already programmed:**

- 01** • Press and hold the OPEN button of an already programmed remote control for 15 seconds.
- 02** • After 15 seconds, the control board emits 5 quick beeps. Release the already programmed remote control button  
(If you continue to press the button, the control board will signal with long and fast beeps).
- 03** • Press and hold the OPEN button of the remote control you want to program.
- 04** • Keep the OPEN button pressed for 10 seconds, during which the control board emits 5 slow beeps.
- 05** • After 10 seconds, the control board emits 3 quick beeps confirming the programming success. release the remote control button to finish programming the 3 buttons.
- 06** • If desired, you can add more remote control for 10 seconds. If you press a remote control already programmed hears long, fast beeps.
- 07** • After 10 seconds without any activity, the programming exits, signaled by 3 beeps.

## 04. PROGRAMMING

### PROGRAMMING REMOTE CONTROLS THROUGH A ALREADY PROGRAMMED ONE

#### **Program a new remote control (1 button) through another already programmed:**

- 01** • Press and hold the OPEN button of an remote control already programmed for 15 seconds.
- 02** • After 15 seconds, the control board emits 5 quick beeps. Release the button of the remote control already programmed.
- 03** • Press and hold the OPEN button of the remote control you want to program.
- 04** • Keep the OPEN button pressed for 10 seconds during which the control board emits 5 slow beeps. After this time, the control board emits 2 fast beeps.
- 05** • Keep the OPEN button pressed for another 6 seconds, during which the control board emits 3 slow beeps.
- 06** • After the total 16 seconds (10+6), the control board emits 3 quick beeps confirming the programming success.
- 07** • If you want, you can add more remote controls for 10 seconds. If you press a remote control already programmed hears long, fast beeps.
- 08** • After 10 seconds without any activity, the programming exits, signaled by 3 beeps.



If the remote control already programmed has 3 buttons, press the up button. If it's just one button, press the programmed button.

### PROGRAMMING OF REMOTE CONTROLS THROUGH SWITCH

#### **Program a new remote control (1 button) using a double switch:**

- 01** • Press and hold the OPEN and CLOSE buttons of the switch for 15 seconds.
- 02** • After 15 seconds, the control board emits 8 quick beeps. Release the OPEN and CLOSE buttons on the switch.
- 03** • Press and hold the OPEN button of the remote control you want to program.
- 04** • Keep the OPEN button pressed for 10 seconds, during which the control board emits 5 slow beeps.
- 05** • After these 10 seconds, the control board emits 3 quick beeps.
- 06** • Keep the OPEN button pressed for another 6 seconds, during which the control board emits 3 slow beeps.
- 07** • After the total 16 seconds (10+6), the control board emits 3 quick beeps confirming the programming success.
- 08** • If you want, you can add more remote controls for 10 seconds. If you press an already programmed remote control, you will hear long, fast beeps.
- 09** • After 10 seconds without any activity, the programming exits, signaled by 3 beeps.

#### **Program a new remote control (1 button) via a single switch:**

- 01** • Press and hold the switch button for 15 seconds.
- 02** • After 15 seconds, the control board emits 5 quick beeps. Release the OPEN and CLOSE buttons on the switch.
- 03** • Press and hold the OPEN button of the remote control you want to program.
- 04** • Keep the OPEN button pressed for 10 seconds, during which the control board emits 5 slow beeps.
- 05** • After these 10 seconds, the control board emits 3 quick beeps.
- 06** • Keep the OPEN button pressed for another 6 seconds, during which the control board emits 3 beeps slow.
- 07** • After the total 16 seconds (10+6), the control board emits 3 quick beeps confirming the success of the schedule.
- 08** • If you want, you can add more remote controls for 10 seconds. If you press a remote control already programmed hears long, fast beeps.
- 09** • After 25 seconds without any activity, the programming exits, signaled by 3 beeps.



## 04. PROGRAMMING

### PROGRAMMING OF REMOTE CONTROLS THROUGH SWITCH

---

#### Program a new remote control (3 buttons) using a double switch:

- 01 • Press and hold the switch button for 15 seconds.
- 02 • After 15 seconds, the control board emits 5 quick beeps. Release the already programmed remote control button (if keep pressing the button the control board will signal with long, fast beeps).
- 03 • Press and hold the OPEN button of the remote control you want to program.
- 04 • Keep the OPEN button pressed for 10sec, during which the control board emits 5 slow beeps.
- 05 • After 10 seconds, the control board emits 3 quick beeps confirming the programming success.
- 06 • If you want, you can add more remote controls for 10 seconds. If you press a remote control already programmed hears long, fast beeps.
- 07 • After 10 seconds without any activity, the programming exits, signaled by 3 beeps.

#### Program new remote control (3 buttons) via single switch:

- 01 • Press and hold the switch button for 15 seconds.
- 02 • After 15 seconds, the control board emits 5 quick beeps. Release the already programmed remote control button (if keep pressing the button the control board will signal with long, fast beeps).
- 03 • Press and hold the OPEN button of the remote control you want to program.
- 04 • Keep the OPEN button pressed for 10 seconds, during which the control board emits 5 slow beeps.
- 05 • After 10 seconds, the control board emits 3 quick beeps confirming the programming success.
- 06 • If you want, you can add more remote controls for 10 seconds. If you press a remote control already programmed hears long, fast beeps.
- 07 • After 10 seconds without any activity, the programming exits, signaled by 3 beeps.

### DELETE REMOTE CONTROLS

---

#### Delete all remote controls using an already programmed remote control:

- 01 • Press continuously the OPEN and CLOSE buttons of an already programmed remote control.
- 02 • Connect the control board to a 230V power supply.
- 03 • Keep the OPEN and CLOSE buttons pressed for 10 seconds, during which the control board emits 5 slow beeps.
- 04 • After 10 seconds, the control board emits 1 beep 2 seconds confirming the programming success.

#### Erase all remote controls via a double switch:

- 01 • Press and hold the OPEN and CLOSE buttons of the switch.
- 02 • Connect the 230V power supply to the control board.
- 03 • Keep the OPEN and CLOSE buttons pressed for 10 seconds, during which the control board emits 5 slow beeps.
- 04 • After 10 seconds, the control board emits 4 quick beeps warning you to release the button.
- 05 • After 10 seconds, when releasing the button, the control board emits 1 long beep (2 seconds) signaling the success of the operation.
- 06 • After 16 seconds from the beginning of the operation, if you do not release the button, the control board emits 3 beeps in 3 seconds, indicating an error in the operation.

## 04. PROGRAMMING

### CHANGE THE MOTOR DIRECTION

---

- 01 • Press and hold the CLOSE button of an already programmed remote control.
- 02 • Connect the control board to a 230V power supply.
- 03 • Keep the CLOSE button pressed for 10 seconds, during which the control board emits 5 slow beeps.
- 04 • After 10 seconds, the control board emits 1 long beep 2 seconds confirming the programming success.