

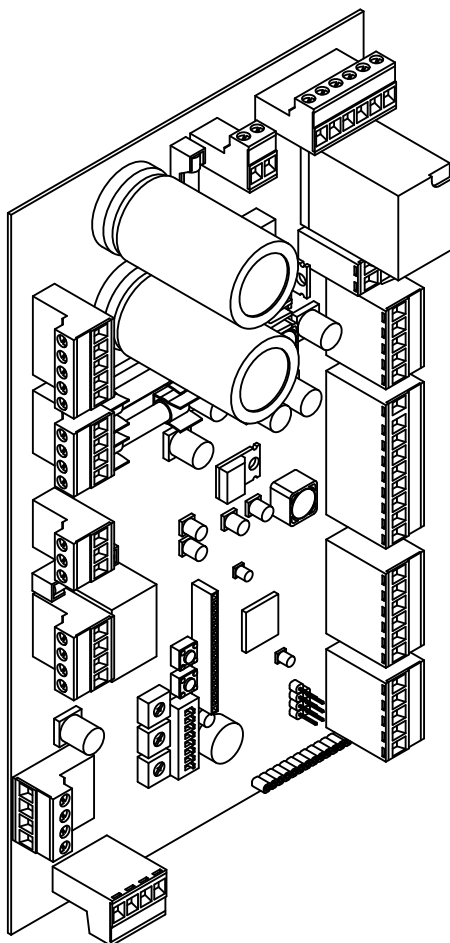

## CP1 CP2 CP4 CP1S CP2S CP4S CP1K CP2K CP4K CP1SK CP2SK CP4SK



The undersigned Mr. Luigi Benincà, legal representative of the company **Rise S.r.l.** - Via del Capitello, 42 - 36035 Marano Vicentino (VI) – in the capacity of manufacturer declares that the product:

**CP1/CP2/CP4**  
**CP1S/CP2SCP4S**  
**CP1K/CP2K/CP4K**  
**CP1SK/CP2SK/CP4SK**

- EMC Directive 2004/108/EC and following amendments  
- Low Voltage Directive 2006/95/EC and following amendments  
and that all norms and technical specifications mentioned below have been applied:

- EN 61000-6-4 (2007)
- EN 61000-3-2 (2006)
- EN 61000-3-3 (1995) + A1 (2001) + A2 (2005) + IS1 (2005)
- EN 61000-6-2 (2005)
- EN 60529 (1991) + A1 (2000)
- EN 60204-1 (2006)

Last two figures of the year when EC has been used: 09

Marano Vicentino, 16/12/2010.

The legal representative

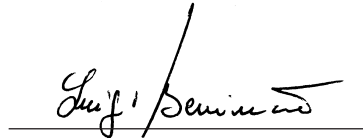

A handwritten signature in black ink, appearing to read 'Luigi Benincà', is written over a horizontal line.

Fig. 1 -CP1/CP1S/CP1SK

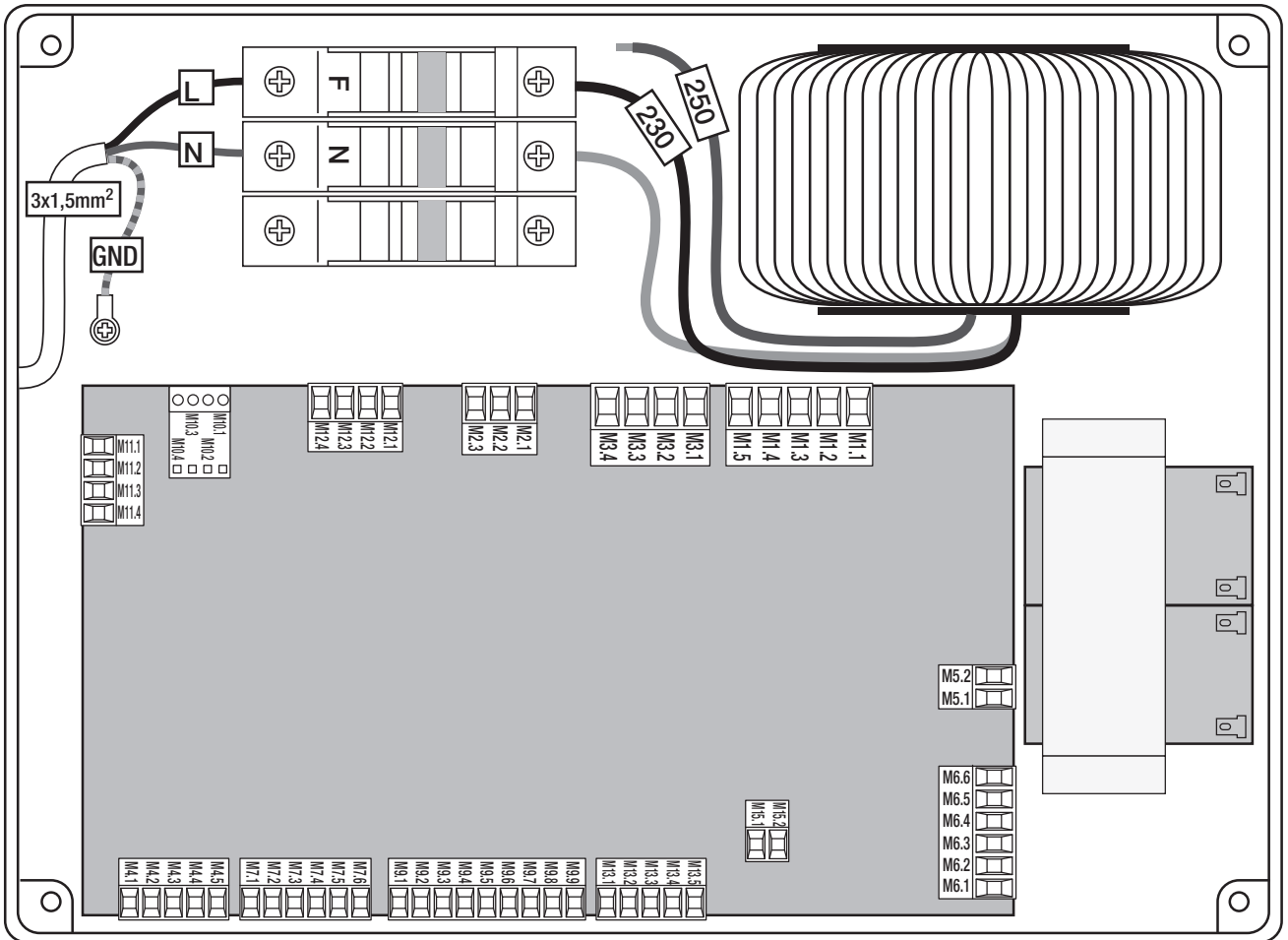

Fig. 2 -CP2/CP2S/CP2SK

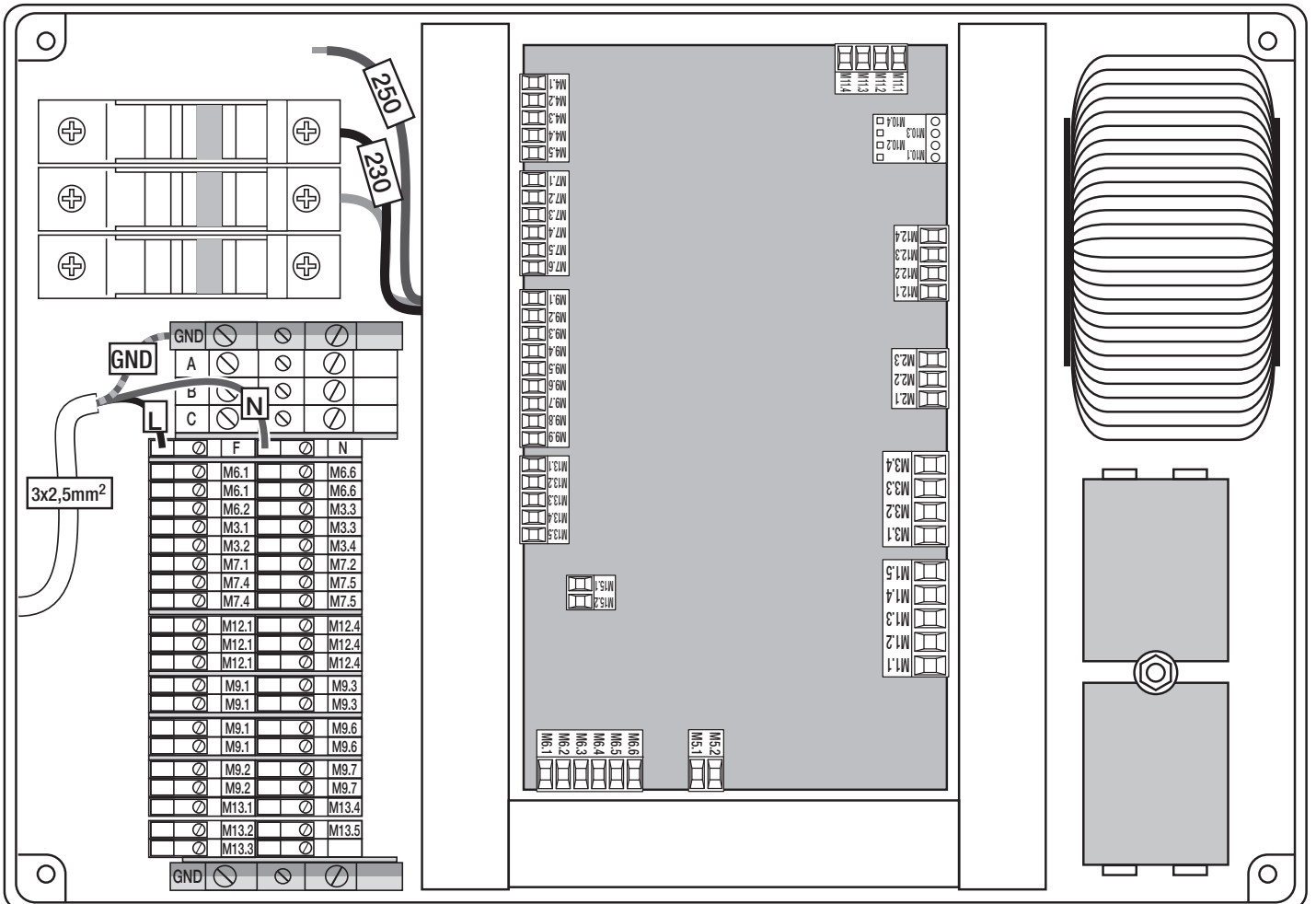

Fig. 3 -CP4/CP4S/CP4SK

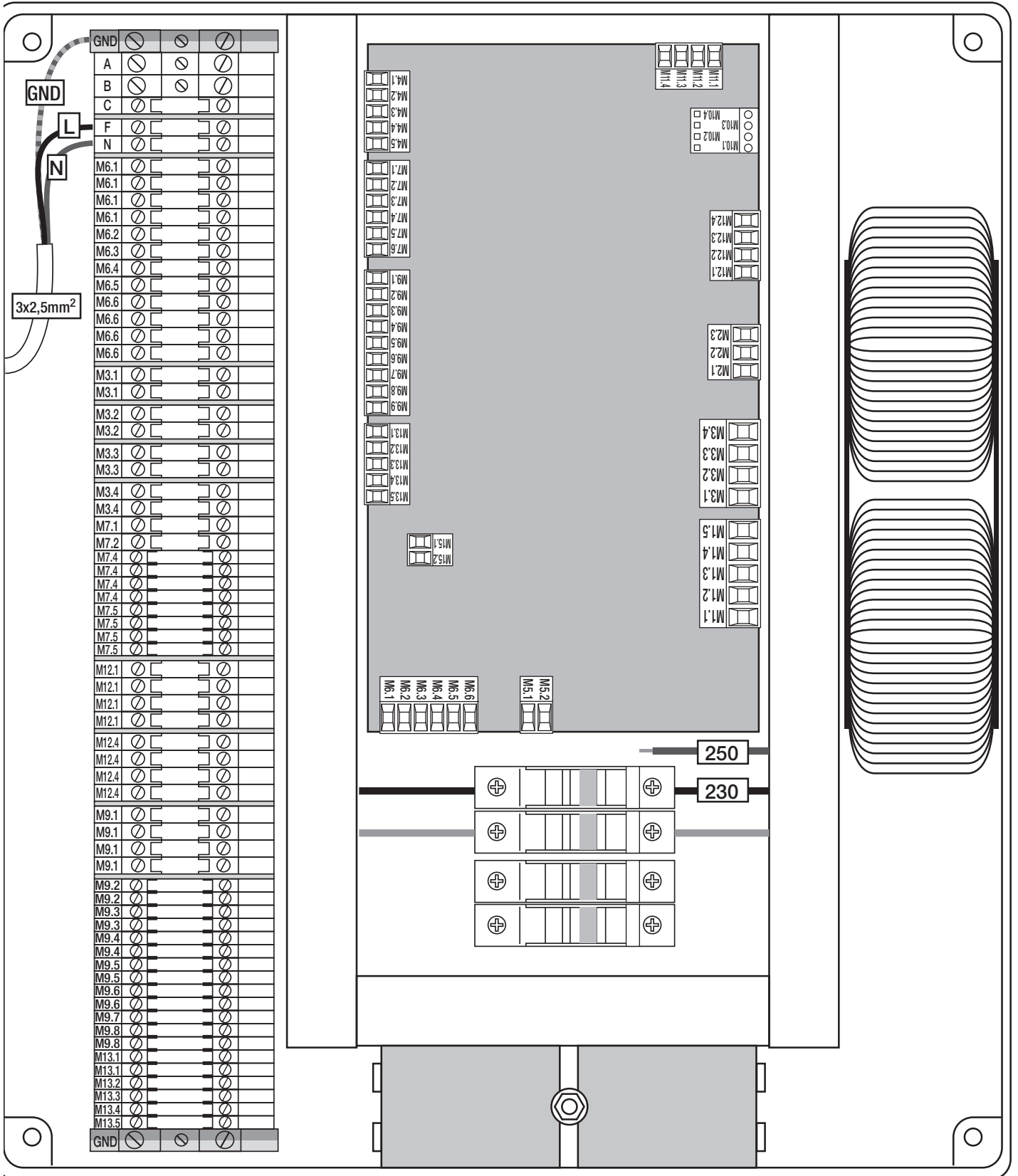



Fig. 6 -CP1/CP1S/CP1SK - Cabling for 1 bollard

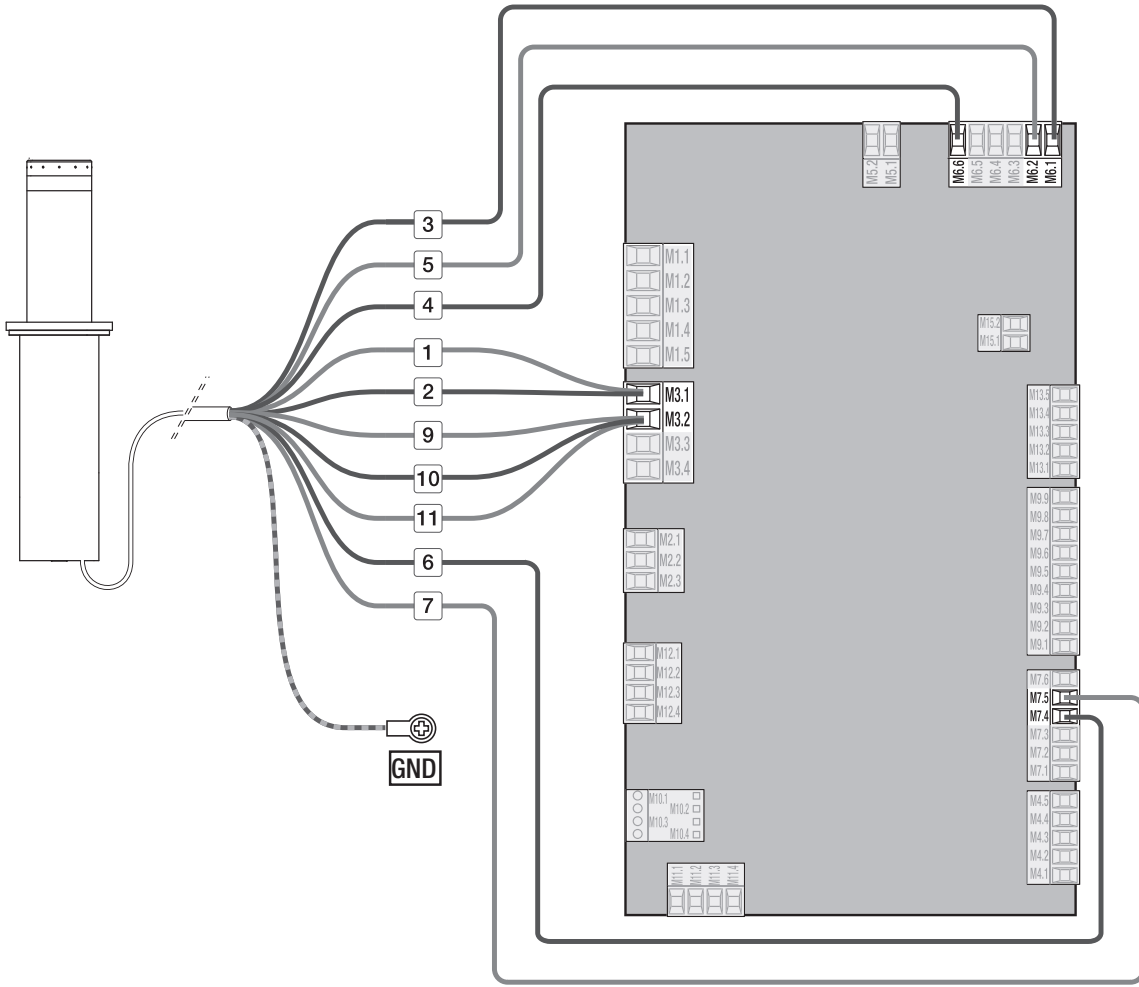

Fig. 7 -CP2/CP2S/CP2SK - Cabling for 2 bollards

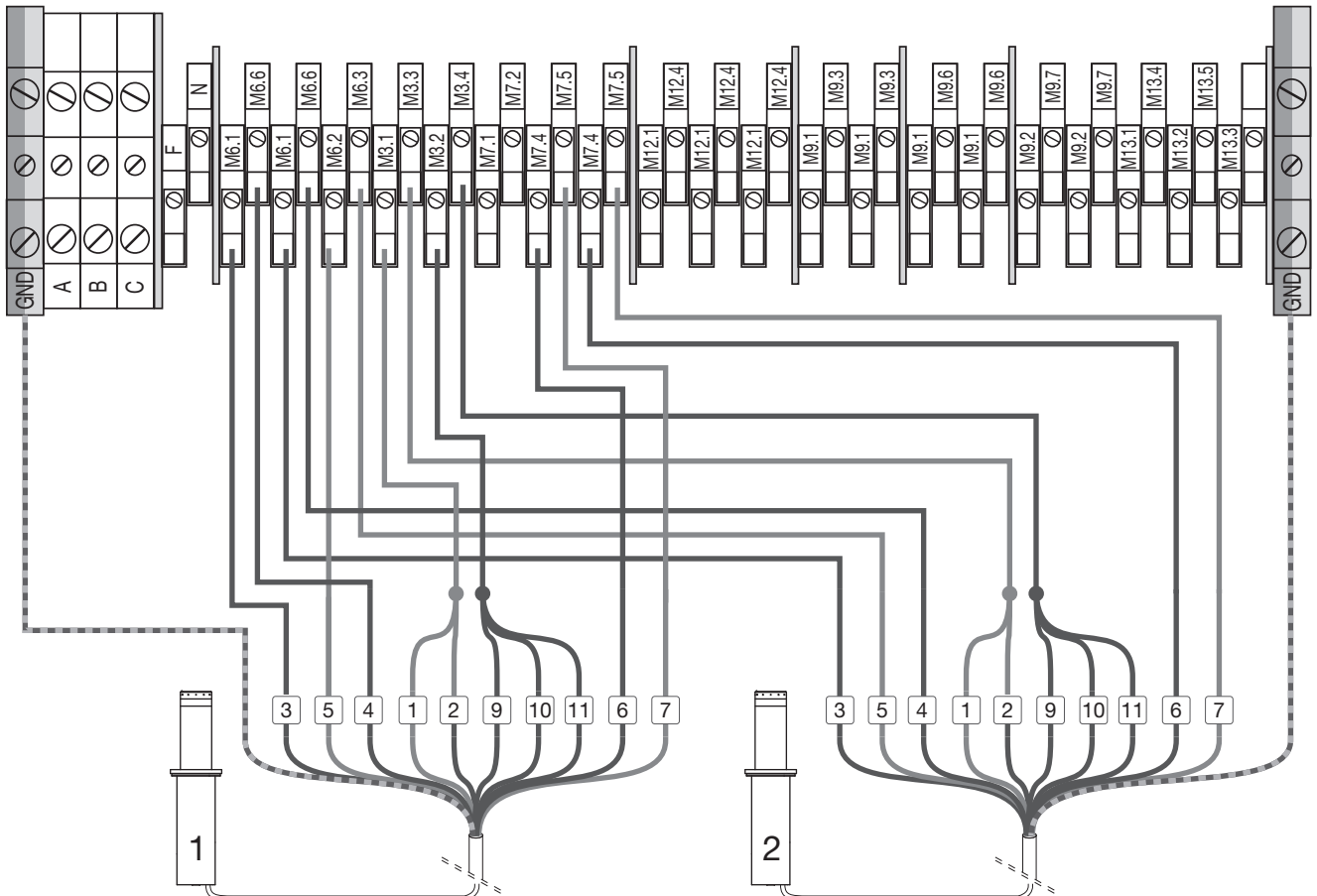
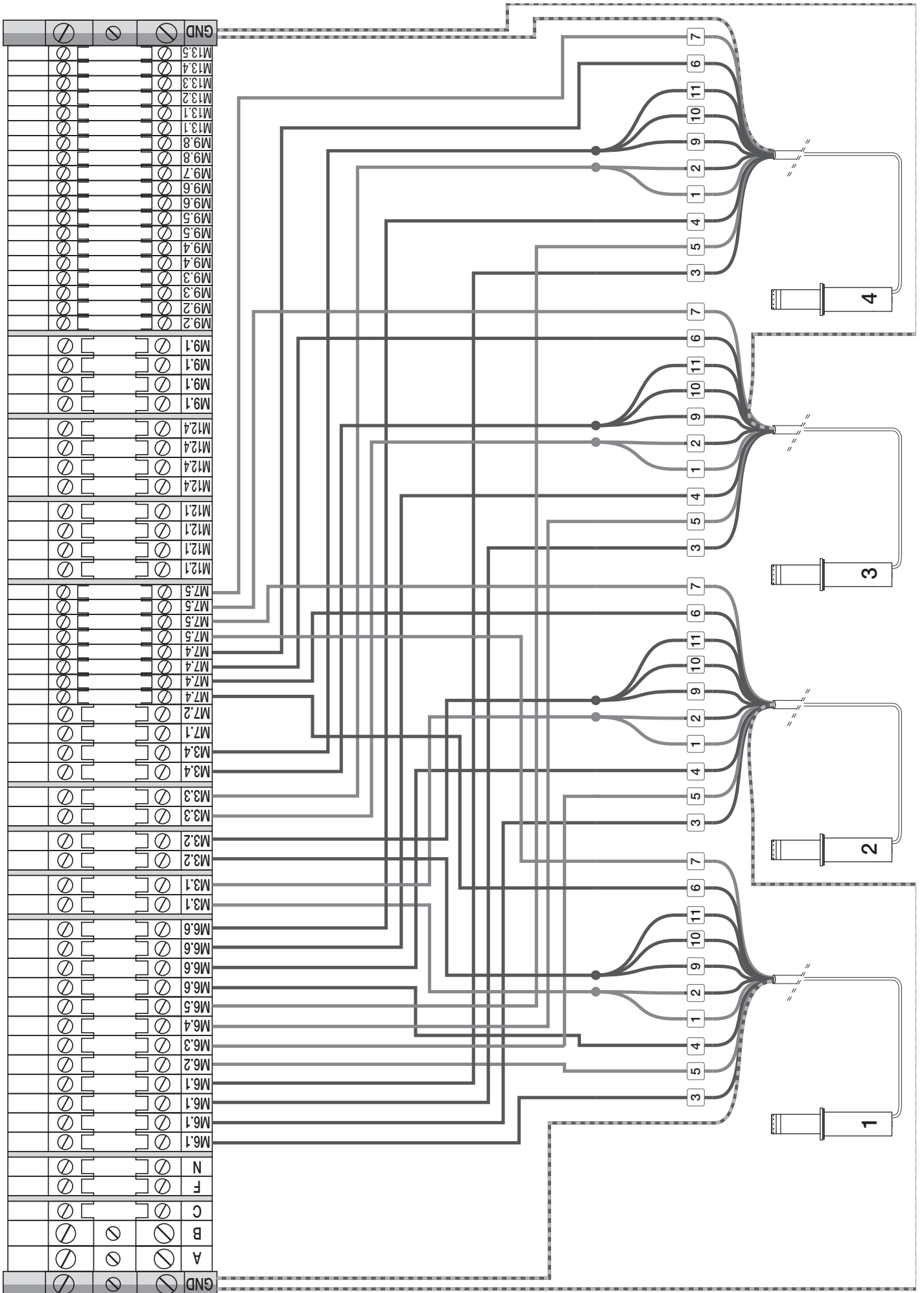

Fig. 8 - CP4/CP4S/CP4SK - Cabling for 4 bollards



**GENERAL INFORMATION**

Control unit for one or more bollards in the Vigilant and Force series, available in several versions:

- CP1 unit for 1 Vigilant 500/l bollard (Fig.1)
- CP2 unit for 2 Vigilant 500/l bollards (Fig.2)
- CP4 unit for 4 Vigilant 500/l bollards (Fig.3)

- CP1S unit for 1 Vigilant 800/l or Force 525/l-Force 825/l bollard (Fig.1)
- CP2S unit for 2 Vigilant 800/l or Force 525/l-Force 825/l bollards (Fig.2)
- CP4S unit for 4 Vigilant 800/l or Force 525/l bollards (Fig.3)

All the units above can also be provided with a pre-cabled emergency battery unit (UPS) CP1K-CP2K-CP4K and CP1SK-CP2SK-CP4SK.

All the units have CPU control logics (Fig.4).

All the Force and Vigilant bollards have a POWER control board situated under the cover of the cylinder (Fig. 5).

Connect the control unit and bollard using the cable with IP68 quick connector, which comes in various lengths according to the distance between the unit and the bollard.

**ELECTRICAL CONNECTIONS**

Refer to the wiring diagram for the number of bollards to be connected to the unit:

- Fig.6 Connection of CP1/CP1S/CP1K/CP1SK to 1 bollard.
- Fig.7 Connection of CP2/CP2S/CP2K/CP2SK to 2 bollards.
- Fig.8 Connection of CP4/CP4S/CP4K/CP4SK to 4 bollards.

If using more than 1 bollard, **EACH BOLLARD MUST BE ASSIGNED A DIFFERENT ADDRESS ON THE POWER BOARD** using the DIP1 switch shown in Fig. 5.

When connecting a single bollard, the wires should be attached directly to the extractable connectors on the CPU board (as shown in the diagrams).

In the case of units CP2 and CP4, the CPU board is connected to a terminal block in line that replicates the numbers of the connectors on the CPU board.

A note on 250V power supply: the unit supplied is usually for a mains voltage of 230V. If the mains voltage is more than 230V (240/250V), simply remove the wire (marked 230V) between the transformer and the output of the fuse holder (L), and in its place connect the wire marked 250V, as shown in Figures 1/2/3.

The CPU control board is the same for all versions of the unit. The functions of the various inputs/outputs and operating logics are described further on. In the interest of simplicity, please refer to the illustrations of the CP1 board. The connections and functions are, in any case, the same for the CP2 and CP4 units.

**IMPORTANT:** The units for 2 and 4 bollards have an ABC terminal block for controlling use of the bollard even when the board is broken or there is no power supply. Refer to the section on the "ABC Terminal Block".

At the end of this manual are various wiring diagrams for all the units. These illustrate the connections between the CPU and the power supply, the transformer, the electric brake batteries and an optional relay (KA1) for automatic lowering in the event of a power cut\*. Instructions are also given on how to connect the M10 terminal block to the control relay of the green/red light.

*The bollard is normally held in place by an electric brake. In the absence of power supply on CP1/2/4 board, the batteries feed the electric brake allowing the descent of the bollard. This function is performed automatically when the relay KA1 is installed.*

**Advice for installation**

- a) The electrical installation and the operating logic must conform with the regulations in force.
- b) It is advisable to keep the power cable (motor, power supply) separate from the control cables (buttons, photocells, radio); to avoid interference it is preferable to provide and use two separate sheaths (see EN 60204-1 15.1.3).
- c) Check all the connections made again before powering up.
- d) Check that the Dip Switch settings are as desired.
- e) The N.C. inputs that are not used must remain free.

**ATTENTION!**

**The faston and/or M5 connector is disconnected from the batteries upon delivery of the unit.**

**Reconnect to the batteries only after connecting the power.**

**FUNCTION OF THE CPU INPUTS/OUTPUTS**

**Inputs/Outputs function**

There are terminal boards for connection:

**Terminal board M9 - pin 9.1-9.9**

**8 digital control inputs** of which:

**4 inputs** to control the rising/descent of the bollards in "STEP by STEP" mode (when the key is pressed, if the bollard is down it is lifted and vice-versa)

**2 inputs** for general control:

Input 9.6: "ALL DOWN" all the bollards connected to the control unit go down IRRESPECTIVE OF THEIR POSITION

Input 9.7: "ALL UP" all the bollards connected to the control unit rise IRRESPECTIVE OF THEIR POSITION. It is recommended to have these controls always available to synchronise the bollards or to make an emergency descent.

Input 9.8: "PROTECTION INVERSION". Input with N.O. contact for photocell or external control device. During ascent maneuver, the intervention of this input causes the immediate reversal of the maneuver. To be used as additional protection to other protections (loops and / or photocells).

All the inputs are of the "clean contact" (N.O.) type so they may be controlled by all the control modules in clean contact with output relays such as radio control receivers, transponder receivers, numerical keypad receivers, normal up/down buttons and any module with a clean contact relay at output: it is sufficient to connect the common wire of the terminal board **M9 pin 9.1 - Com in** to the desired control.

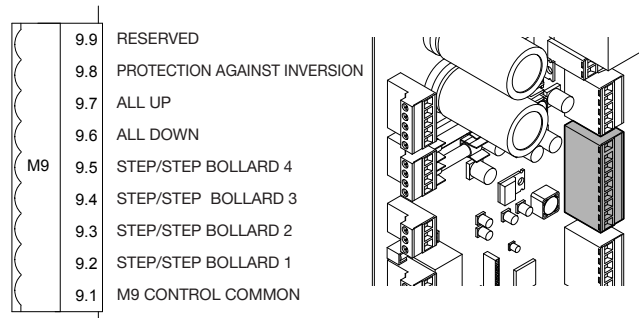

**Terminal board M13 - pin 13.1-13.5**

Input terminal block N.C. contacts for Protection devices (loops or Photocell).

Always use the contact M13.1/M13.2 for general controls. In the case of step by step functions on configuring the "SP1", up to 4 independent safety devices for each bollard can be used.

ALWAYS FOLLOW the configuration order related to the bollard:

- LOOP INPUT 1> BOLLARD 1
- LOOP INPUT 2> BOLLARD 2
- LOOP INPUT 3> BOLLARD 3
- LOOP INPUT 4> BOLLARD 4

General controls: LOOP INPUT 1> BOLLARD 1+2+3+4

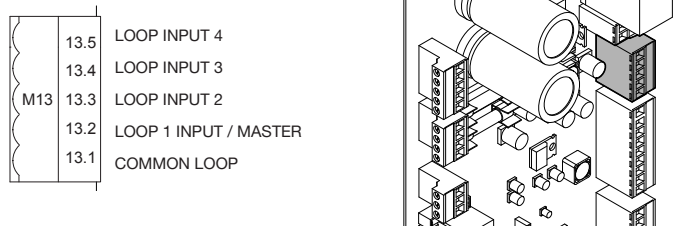

**Terminal board M6 - pin 6.1-6.6**

**Emergency terminal board:** for making the bollards go down in the event of a power cut and/or faulty boards there is a **RED button** on the board for making an emergency descent (electronic faults); in this case the software is bypassed and the bollards are positioned at ground level by holding the button down for the necessary time; on the electromechanical box that houses the control unit there may be further terminals for releasing and lifting the bollards, for removing the cover and changing the power boards, the motor, etc. ... in the case where these are faulty and no electronic command or software is working - (at least the motor brake must be working, the wiring must not be interrupted and the batteries must be charged).

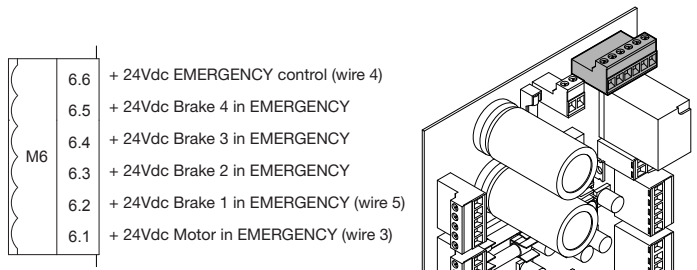



**Terminal board M15 - pin 15.1-15.2**

**Automatic descent terminal:** this is a contact parallel to the button above; it may be connected to a clean NC contact of a relay controlled directly by the main power supply at 230 volt~. If there is no input power, this contact closes and lowers all the bollards connected to the same control unit.

**ATTENTION!**

**If the main power supply is absent for prolonged periods (more than 6/8 hours), it is recommended to disconnect the battery faston and to put them back into service when the mains supply returns (the bollards remain down and in rest position without any danger); otherwise, as for all antitheft devices and UPS backup systems, the batteries could be spoiled and would have to be replaced.**

The system has been designed to be always powered 24 hours a day; it works with the UPS (if present) for brief interruptions in the power supply (a few hours); if it is deactivated or switched off for long periods, it is necessary to set the bollards "all down" in rest position and to disconnect the fuse holders and battery contacts. When power returns it is sufficient to put the control unit back into service with a very simple operation, turning on the main switch if present, or reconnecting the fuse holders and the batteries.

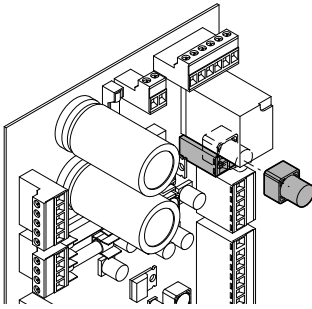

**Terminal board M5 - pin 5.1-5.2**

An automatic battery charger is built into the control unit, able to charge and keep buffered two 12 Volt batteries in series (24 Volt line) of various sizes; the batteries are needed to use the emergency release/functions in the absence of 230 Volt mains power or when there are malfunctions of the boards, and for the **OPTIONAL UPS** function which feeds the control unit and all the Power boards integrated in the bollards and all the modules in the box in the absence of 230 Volt mains power.

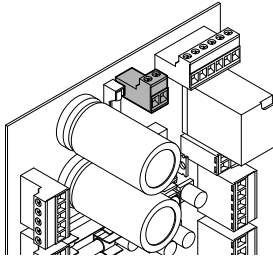
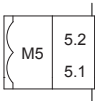

**Terminal board M7 - pin 7.1-7.6**

**Communication between POWER boards and CPU RS-485** communication bus between a control unit and up to 4 POWER boards (built into the bollard), a second RS-485 bus is contemplated for future implementations; **the length of the cable between the control unit and each bollard must be limited possibly within 20 metres (10-15 recommended).**

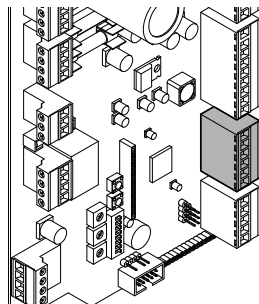
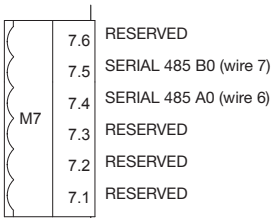

**Terminal board M3 - pin 3.1-3.2-3.4-3.4 - Power supply output for bollard**

Connect the bollard to be controlled to M3 terminal board:

**Pin 3.1 (use also 3.3 on CP2/CP4) :**

**Pin 3.1:** Positive power supply (+ wires 1, 2 from the bollard) **+32Volt DC1 OUT Supply.**

**Pin 3.2 (use also 3.4 on CP2/CP4):**

Negative power supply (- wires 9, 10, 11 from the bollard) **-GND Supply.**

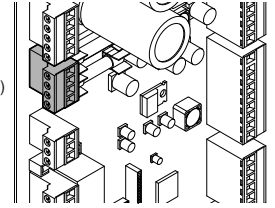
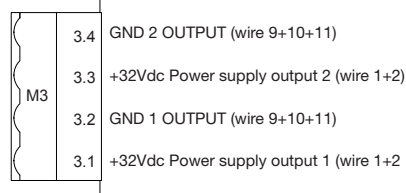

**M4 terminal block - pin 4.1-4.5**

By placing the jumper on this terminal, you can enable or disable certain features.

**M4.1-M4.2: ANTI-REFRESH.** Bridging these two terminals activate the anti-refresh function which is to prevent re-running an up command when the bollard is already up or down command if it is already down. To be Used when a large number of users are operating the bollard by mean of remote control.

**M4.1-M4.3: PRE-WARNING FLASHING TIME.** Bridging these two terminals the TR3 trimmer adjust the time scale from 0s to 100s.

In absence of jumper the time scale range from 0s to 10s.

**M4.1-M4.4: IGNORE SAFETY.** Bridging these two terminals will enable the bollard to raise even if the NC contact of the protection (loop or photocell) is open. It thus bypasses the security input, exclusively to be used to test the proper functioning of safety devices in case of malfunctions.

Valid only with configurations from SP2 to SP6.

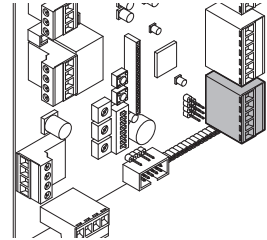
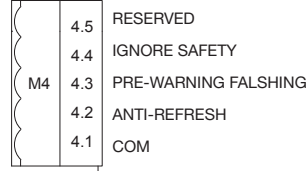

**Terminal board M11 - pin 11.1-11.4 Output for 24 Vdc/1A max buzzer .**

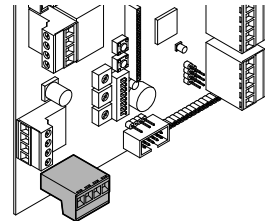
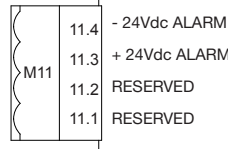

**Terminal block M12**

**Pin 12.1-12.4 Fixed output for power of external modules 24 Vdc/1A.**

**Pin 12.2-12.4 Step by Step output 24Vdc/1A max controlled by the third channel of the integrated radio receiver.**

**Pin 12.3-12.4 Step by Step output 24Vdc/1A max controlled by the third channel of the integrated radio receiver.**

The two outputs are in parallel and switch simultaneously with the third radio channel.

**Traffic light board control for 2 traffic lights:** 1<sup>st</sup> normally red on the outside changing to green on the outside, 2<sup>nd</sup> normally red on the inside changing to green on the inside according to the work cycle.

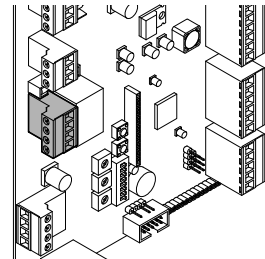
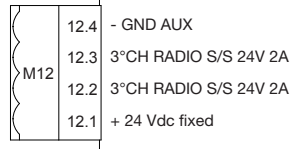

**Terminal board M10 - pin 10.1-10.4**

**Traffic light board control for 2 traffic lights:** 1<sup>st</sup> normally red changing to green, 2<sup>nd</sup> normally red changing to green according to the work cycle.

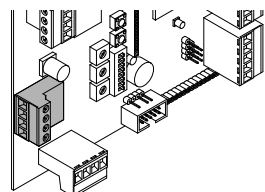

Note:

If you use RISE LED traffic light, simply link the connector to the M10 terminal which automatically controls the lights and the alimentation of the traffic light.  
 If you are using a 230V standard traffic light it is necessary to use the relay as shown in the wiring diagrams (last pages of the manual)

**Trimmer Function**

**TR1 Trimmer :** Adjust the automatic rising time, after the intervention of loops and photocells, adjustable from 6 to 66 seconds

**TR2 Trimmer :** Adjust the switching time of traffic lights. The switching time from RED to GREEN, after the complete lowering movement of the bollard, adjustable from 0 (instant switching) to 30 seconds.

**TR3 Trimmer:** Adjust the maneuver pre-warning time from 0, up to 10 seconds. If there is a bridge between M4.1 and M4.3 terminals, the pre-warning flashing time becomes adjustable from 0 to 100 seconds.

The buzzer, connected to M11.3/M11.4 terminals, or the red light of the traffic light, pre-warns the movement.

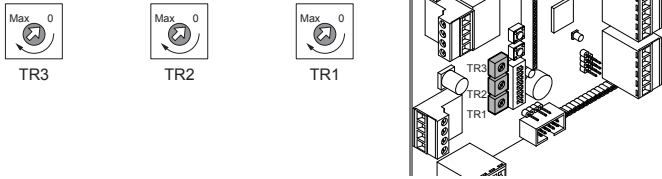

**Fuses - F2, F3, F4, F6**

- F2, F3:** 20/25A Slow 6x32 - Fuse protecting the bollard motor supply.
- F4:** 3.15A Fast 5x20 - Fuse protecting the buffer battery charge.
- F6:** 3.15A Slow 5x20 - Fuse protecting 24V external modules.

**Diagnostics:**

**RED LED:** normally off, if fast blinking the power supply is missing due to an interrupted fuses line or the 18 Vac supply, to M2.1/M2.2 terminals for auxiliary 24 Vdc on M12 terminal block, is missing.

**YELLOW LED:** Indicates the RS485 data bus between the CPU and the bollard. Normally flashes quickly with a short break every second to indicate the CPU/bollard communication in progress. For each command, the LED turns off for about 3 seconds and then resumes flashing quickly with breaks.

**GREEN LED:** Indicates the activity on the receiver RR.WBS, eventually installed on the CPU. It flashes for 0.5s after each activation on one of the 4 available channels.

**BLUE LED:** If on, it indicates that M13.2 contact input loop 1 master is closed, loop connected in stand-by position. When a metal mass is detected, the LED turns off.

**BUZZER:** Located in the CPU board. Report with two frequencies battery status and consequently the operation of the integrated charger and all the fuses inside and outside, UPS contactor, relay and any device that may refer to the system with battery / charger.  
**FAST SOUND:** Indicates the alarm status overcharging of the battery, short circuit of battery charger, contactor UPS connected incorrectly (or stucked contacts), incorrect connection of the positive pole.  
**SLOW SOUND:** Indicates the status of low battery or short circuit, or more likely an interrupted fuse. Verify by consulting the wiring diagram (at the end of this manual) corresponding to the type of system used.

**MAGNETIC LOOPS:** The loop detectors have integrated diagnostic, refer to the manual supplied with the loop.

**POWER FAILURE:** The main power can be monitored by the Ethernet kit ET1 and the Automatic Lowering Device "AUT" (orange relay) located close to the main line fuses. The NO contact can be connected to one of the 4 inputs of Ethernet Device "ET1", to check the status of the main power.

**BOLLARDS STATUS:** Through the ET1 Ethernet device, connecting the traffic light output and a NO/NC relay is possible to display the bollards status UP/DOWN through an Ethernet port, with the color corresponding to the state of traffic lights (GREEN/DOWN, RED/UP)

**CPU RED BUTTON:** Allows you to check the status of the batteries / chargers, electric brake and mechanical components of the bollard.

**POWER BOARD:** Located into the bollard. If the buzzer, located into the bollard, sounds at fast rate, but the bollard doesn't accept a rising command, but only a lowering one, it means that the system is in thermal protection due to overheating.

**Dip Switch Function**

Inside the control unit there is a module with 8 Dip Switches for choosing various operation and parameterisation modes such as the descent speed, the maximum travel 500 / 800mm, the lifting mode with magnetic coils/photocells, timing functions and other modes.

C	B	A	Cycle	Coil logic Vigilant 500 / Force 525
0	0	0	SP0	Disabled (manual function)
0	0	1	SP1	1 <sup>st</sup> Module 1 <sup>st</sup> Coil - Consent for manual lifting D1-2-3-4
0	1	0	SP2	1 <sup>st</sup> Module 1 <sup>st</sup> Coil - Lifts D1-2-3-4 after the time TR1 if the coil is free (Armed cyc. D1).
0	1	1	SP3	Likewise SP2 + an engaged/free "coil impulse" immediate lifting with fixed time 3 sec.
1	0	0	SP4	Likewise SP3 + reversal if an IN-ALL_DOWN command is given when the bollard is being raised.
1	0	1	SP5	Likewise SP4 + closing cycle in case of power failure (for omologation)
1	1	0	SP6	Likewise SP4 - closing coil signal 3 seconds (reset time TR1 for every event)
1	1	1	SP7	Reserved

C	B	A	Brake level Vigilant 500 / Force 525
0	0	0	Minimum brake
0	0	1	Medium brake 1
0	1	0	Medium brake 2
0	1	1	Medium brake 3
1	0	0	Medium brake 4
1	0	1	Medium brake 5
1	1	0	Medium brake 6
1	1	1	Maximum brake

C	B	A	Brake level Vigilant 800 / Force 825
0	0	0	Minimum brake
0	0	1	Medium brake 1
0	1	0	Medium brake 2
0	1	1	Medium brake 3
1	0	0	Medium brake 4
1	0	1	Medium brake 5
1	1	0	Medium brake 6
1	1	1	Maximum brake

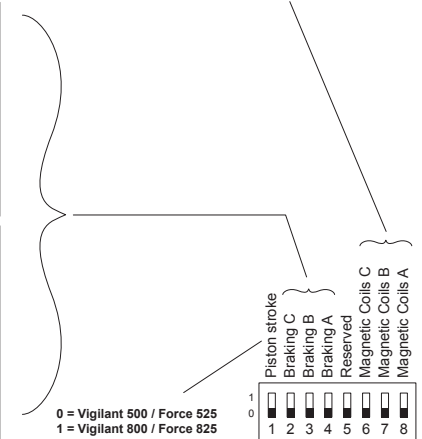

**Standard installation diagram.**

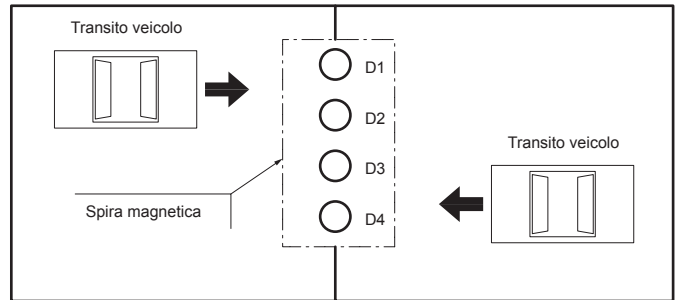

Connect the photocell / loop detector to M13.1/M13.2 terminals, the contact must be NC (normally closed) in stand-by, without any obstacle detected by the two devices.

**Magnetic Coils Logic:**

**Configuration 000 SP0**

The control is completely manual, no loop or protective device is connected. The raising and lowering commands are given by an operator at site.

**Configuration 001 SP1**

This basic configuration needs the presence of an operator at site to give the raising command to the bollards. If an obstacle is on the loop, the raising command is always ignored.

This configuration is recommended where the automatic rising is not requested. It's also recommended, in case of step by step command, this set up in installation with more than one bollard connected to the same CPU board.

In this case, using one loop for each bollard, it is possible to use the following additional inputs:

- M13.1/M13.3 for bollard no. 2
- M13.1/M13.4 for bollard no. 3
- M13.1/M13.5 for bollard no. 4

**IMPORTANT: If you are using a global command connected to M9.1/M9.2, it is necessary to bridge the other inputs (M9.1/M9.3, M9.1/M9.4, M9.1/M9.5) and connect the loops to the master input M13.1/M13.2**

### Configuration 010 SP2

The 4 bollards are lowered by a global "ALL DOWN" control (remote control, button, etc...); only in this case does the automatic lifting cycle begin. The lifting time set by the Trimmer TR1 begins (about 6 to 66 seconds). At the end of the set time: if the spire or photocell is "free" (contact closed), consent is given and the bollard rises automatically; if the coil is "engaged", the bollard stays down even after the set time has elapsed; as soon as the coil is "free" (contact closed), with time already elapsed, the bollard rises immediately.

### Configuration 011 SP3

Similar to the preceding SP2 as regards the management of consent and lifting; in addition there is the "Rapid Closing" logic: after the bollard has been lowered, the countdown begins for the lifting time set by the Trimmer TR1 as for SP2, but if the coil intercepts a lifting impulse "Open-Close" "Coil engaged - Coil free", the bollard lifts "immediately" after a fixed time of three seconds without waiting for the residual time set by TR1.

### Configuration 100 SP4

The same as for the SP3 for managing the commands and raising the bollard; it also has a "MONITOR" which, if it intercepts a global "ALL DOWN" command as the bollard is raised, reverses the process and moves the bollard back down.

NB1: If the "ALL\_DOWN" input is re-closed, the coil time is reset and the counter restarts.

NB2: If the "ALL\_DOWN" input is intercepted when the bollard is being raised, the process is reversed and the bollard moves back down.

NB3: If the coil 1 intercepts a vehicle during the rising time of the bollard, the right-about comes on line.

### Configuration 101 SP5

Same operation as SP4 but without fast automatic raising cycle (3 seconds). The automatic raising cycle occurs after the pre-set time.

In addition, in case of power failure for more than 3 seconds, the bollard makes an "automatic raising cycle": it lowers completely and then it raises up automatically by an "ALL UP" command.

This happens only if the loop detector/photocell is not detecting any obstacle and if the "GLOBAL DOWN" command is not closed.

The system makes the automatic raising cycle after 20 seconds from the complete lowering of the bollard, during this time it makes a double check of the status of loop detectors/photocells and GLOBAL DOWN command, the traffic light remains red.

This function makes the bollard immune to the "voltage dips", especially when it is connected to the AUT relay (automatic lowering device), in absence of power supply (M15 terminal).

Whenever an obstacle is detected by a loop or an "ALL DOWN" command is given, the set time TR1 is reset (function with the longest evacuation time)

NB1: If the "ALL\_DOWN" input is re-closed, the coil time is reset and the counter restarts.

NB2: If the "ALL\_DOWN" input is intercepted when the bollard is being raised, the process is reversed and the bollard moves back down.

NB3: If the coil 1 intercepts a vehicle during the rising time of the bollard, the right-about comes on line.

### Configuration 110 SP6

The same as for the SP4 for managing the commands and raising the bollard except that it doesn't make a fast lift (3 seconds) if intercepts a signal from the coil:

Signal of rise "OPEN --> CLOSE" > "Coil engaged --> Coil free".

But every event resets the coil time TR1 (works with the max time of clearing out of the passage).

Whenever an obstacle is detected by a loop or an "ALL DOWN" command is given, the set time TR1 is reset (function with the longest evacuation time)

NB1: If the "ALL\_DOWN" input is re-closed, the coil time is reset and the counter restarts.

NB2: If the "ALL\_DOWN" input is intercepted when the bollard is being raised, the process is reversed and the bollard moves back down.

NB3: The bollard can rise only after the time count TR1 if it is not resetted from the "ALL DOWN" command or the coil1 input, in this case the bollard stays down and it can't rise.

NB4: If the coil 1 intercepts a vehicle during the rising time of the bollard, the right-about comes on line.

## FUNCTION OF THE POWER INPUTS/OUTPUTS

The POWER board has 5 terminal blocks. Some of the inputs/outputs are already connected to the output cable with quick connector. Other inputs/outputs are connections in the bollard.

Below is a description of the terminal blocks and, in the case of connection to a connector, the respective numbers on the connecting cable.

In some cases several output wires are connected to a single connector; in this case the wires are also grouped together at the connection on the control unit.

### Terminal block M1 - Power supply from CPU unit

M1.1: + Power supply input +32Vdc (Wire 1+2).

M1.2: - GND power supply (Wire 9+10-11).

M1.3: - Earth connection in bollard.

### Terminal block M2 - Motor Encoder connection

M2.1: - GND Encoder - white.

M2.2: + 5Vcc Encoder - red.

M2.3: EB phase B Encoder - blue.

M2.4: EA phase A Encoder - green.

### Terminal block M3 - RS-485 serial connection

M3.1: A RS-485 (Wire 6).

M3.2: B RS-485 (Wire 7).

### Terminal block M4 - Buzzer and anti-freeze element connection

M4.1: + Anti-freeze element

M4.2: - Anti-freeze element

M4.3: + Buzzer (brown wire).

M4.4: - Buzzer (white wire).

Connections for optional accessories pre-installed.

### Terminal block M5 - Motor-Electric brake-Emergency connection

M5.1: + Motor in emergency (Wire 3).

M5.2: + Emergency control (Wire 4).

M5.3: + Brake in emergency (Wire 5)

M5.4: - Jaw brake

M5.5: + Jaw brake

M5.6: + 24Vdc motor internal connection (white)

M5.7: - 24Vdc motor internal connection (brown)

## ABC TERMINAL BLOCK

The ABC terminal block, for models CP2 and CP4, permits use of the bollards when there is a fault with the POWER unit by powering the bollard motors directly, bypassing the control electronics.

If the motors and respective electric brakes are working, it is possible to lift the bollards PARTIALLY for accessing the POWER boards.



- The ABC terminal block must only be used by a qualified technician.
- DO NOT, FOR ANY REASON, FULLY RAISE THE BOLLARD up to the end of its stroke as to do so can damage the 24Vdc motor irreparably.
- Follow this procedure raising the bollard to a maximum of 50% of its stroke for opening the cover and servicing the POWER unit.
- An eye must be kept on the bollards when they are being raised.
- The bollards must all be fully lowered; the procedure cannot be executed if even one bollard is partly or fully raised. Lower any bollards that are raised using the automatic lowering contact.

Follow these instructions one step at a time:

#### 1 - Turn off the power.

2 - Use the 2.5 mm<sup>2</sup> cable to bridge the B-C connectors and connect a temporary N.O.\* (normally open) contact between connectors A and B (as illustrated).

\*Use a button of at least 15A or, preferably, a thermal magnetic circuit breaker of at least 20A. Using buttons of a lower capacity could damage the motors irreparably in the event of the contacts sticking.

3 - Turn the power back on again. Keeping an eye on the bollards, press and hold the NO button; release the button as soon as the bollards are about half-way up.

4 - Turn off the power. Now that the bollards are partly raised, it is possible to access the POWER units.

#### 5 - Remove all the connections on the ABC terminal block

Channel 3 ORANGE LED - performs the switching of 24V M12.2/M12.3 terminals.

Channel 3 YELLOW LED - activate the anti-panic function through M11.3/M11.4 siren output terminals.

If the bollards refuse to move, the motors are clearly at fault. You will need to remove the entire bollard from its foundation box.

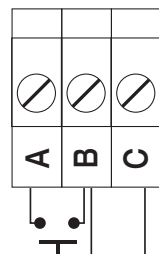

### INTEGRATED RECEIVER

The unit can, on request, be provided with a 3 channel radio module with a frequency of 433.92MHz able to store up to 64 rolling-code transmitters or 1 programmable code.

An antenna (ANT) is pre-installed on the board suitable for most installations. If you need to install an external antenna, connect the signal wire to the ANT wire and the jumper to the M4.1 connector.

The two channels are automatically associated to the functions:

Channel 1 LED RED: All DOWN - all the bollards are lowered.

Channel 2 LED GREEN All UP - all the bollards are raised.

Channel 3 ORANGE LED - performs the switching of 24V M12.2/M12.3 terminals.

Channel 3 YELLOW LED – activate the anti-panic function through M11.3/M11.4 siren output terminals.

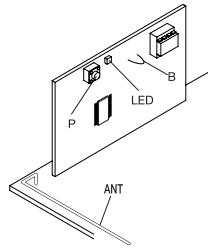

### STORING THE TRANSMITTERS

It is possible to select the type of transmitter with bridge B:

with the bridge closed: rolling-code only.

with the bridge open: rolling-code and programmable.

How to store a transmitter:

- 1 Press button P on the radio receiver
- 2 The LED turns red for about 3 seconds, turns off and then on again.  
To store a transmitter in the first channel (ALL DOWN bollard function), press the button of the transmitter you wish to save within 5 seconds.
- 3 If you press the P button on the receiver again, the LED turns GREEN for about 3 seconds, turns off and then on again.  
To store a transmitter in the second channel (ALL UP bollard function), press the button of the transmitter you wish to save within 5 seconds.
- 4 If you press the P button on the receiver again, the LED turns ORANGE for about 3 seconds, turns off and then on again.  
Do not save transmitters during this phase. The function is reserved for other uses.
- 5 If you press the P button on the receiver again, the LED turns off and the receiver exits the teach-in mode.

To reset the receiver:

Turn off the power, press button P and hold it down while turning the power on again.

The LED turns red and is steady for 5 seconds before flashing and alternating in colour; release the button. The receiver is now reset and all the transmitters are cancelled.



### CP1S

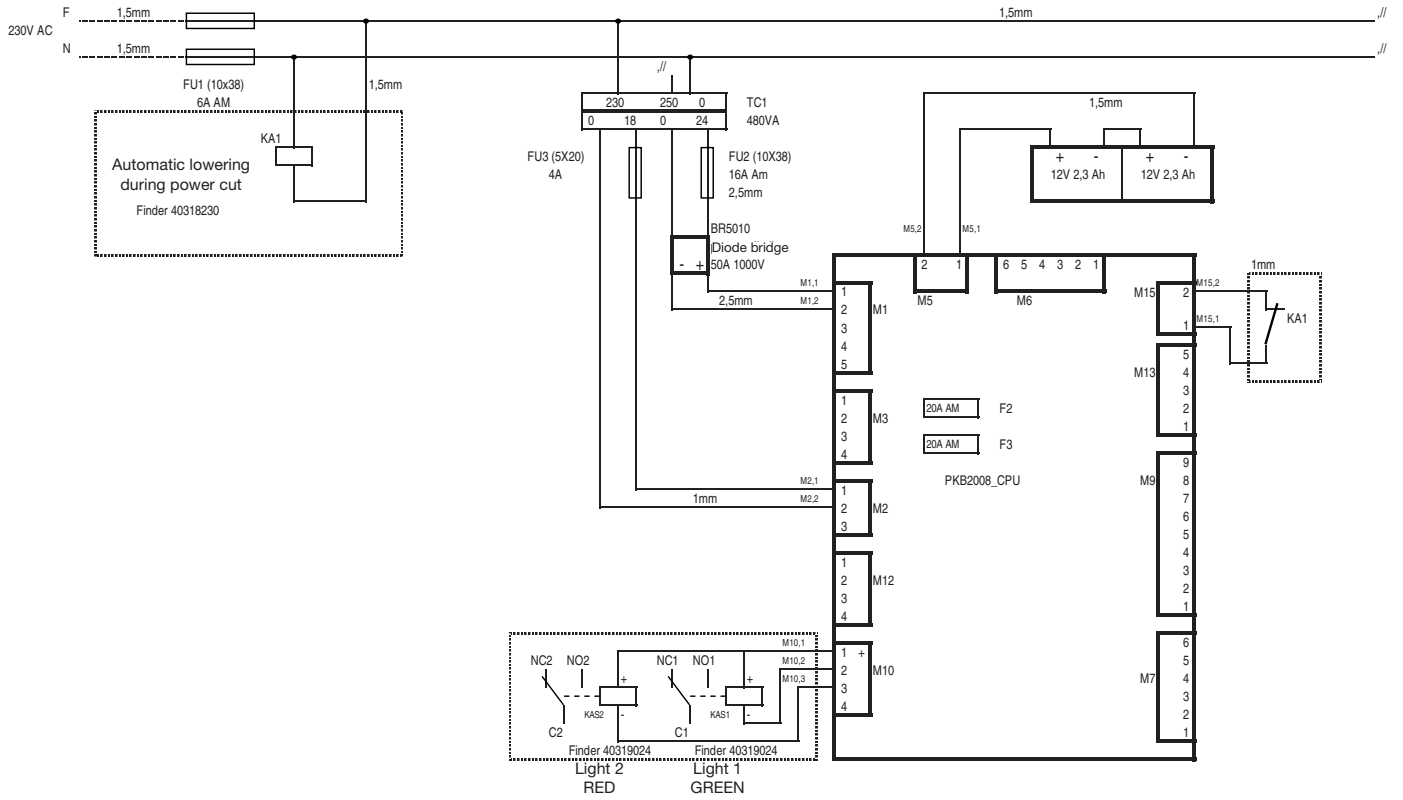

### CP1SK

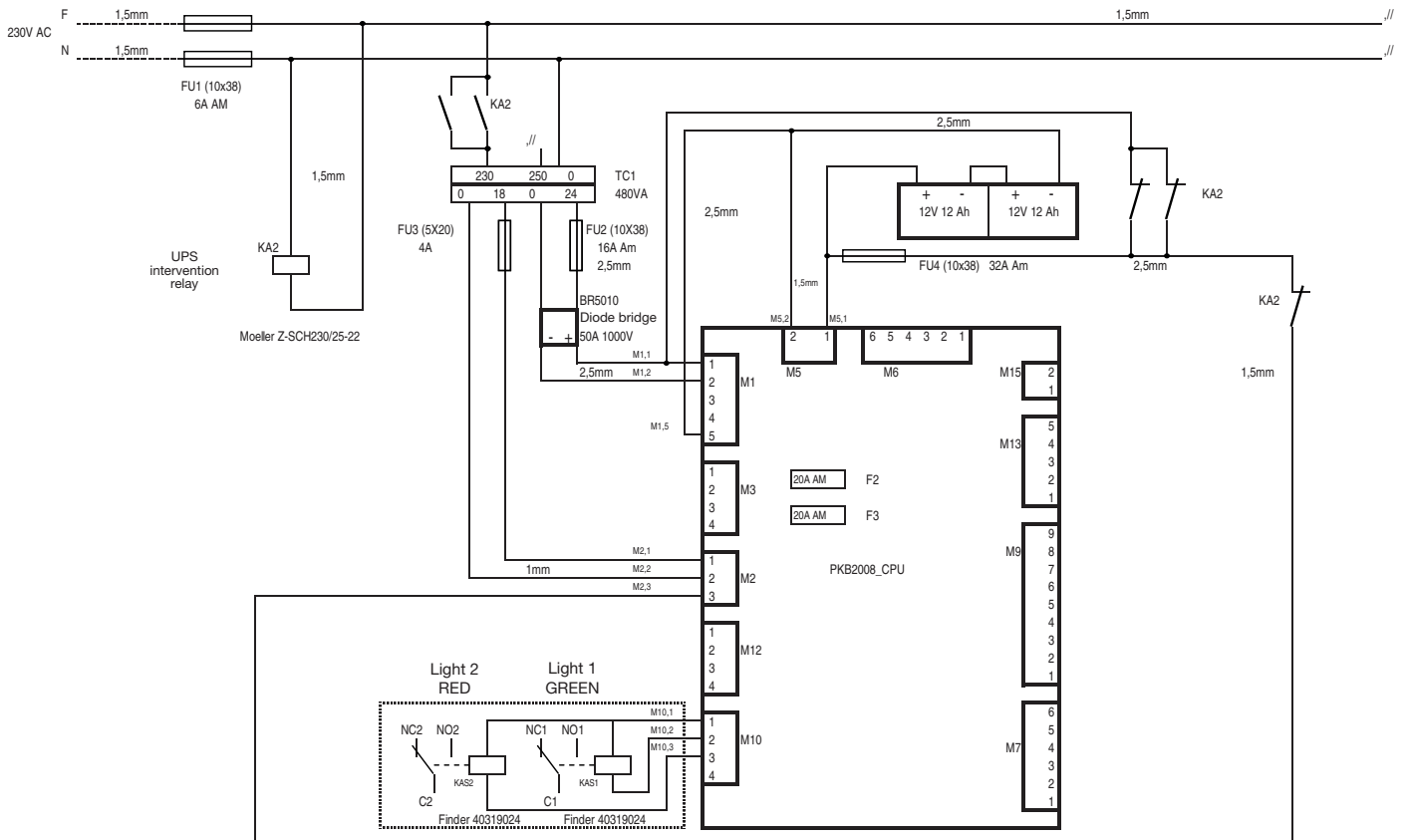

CP2

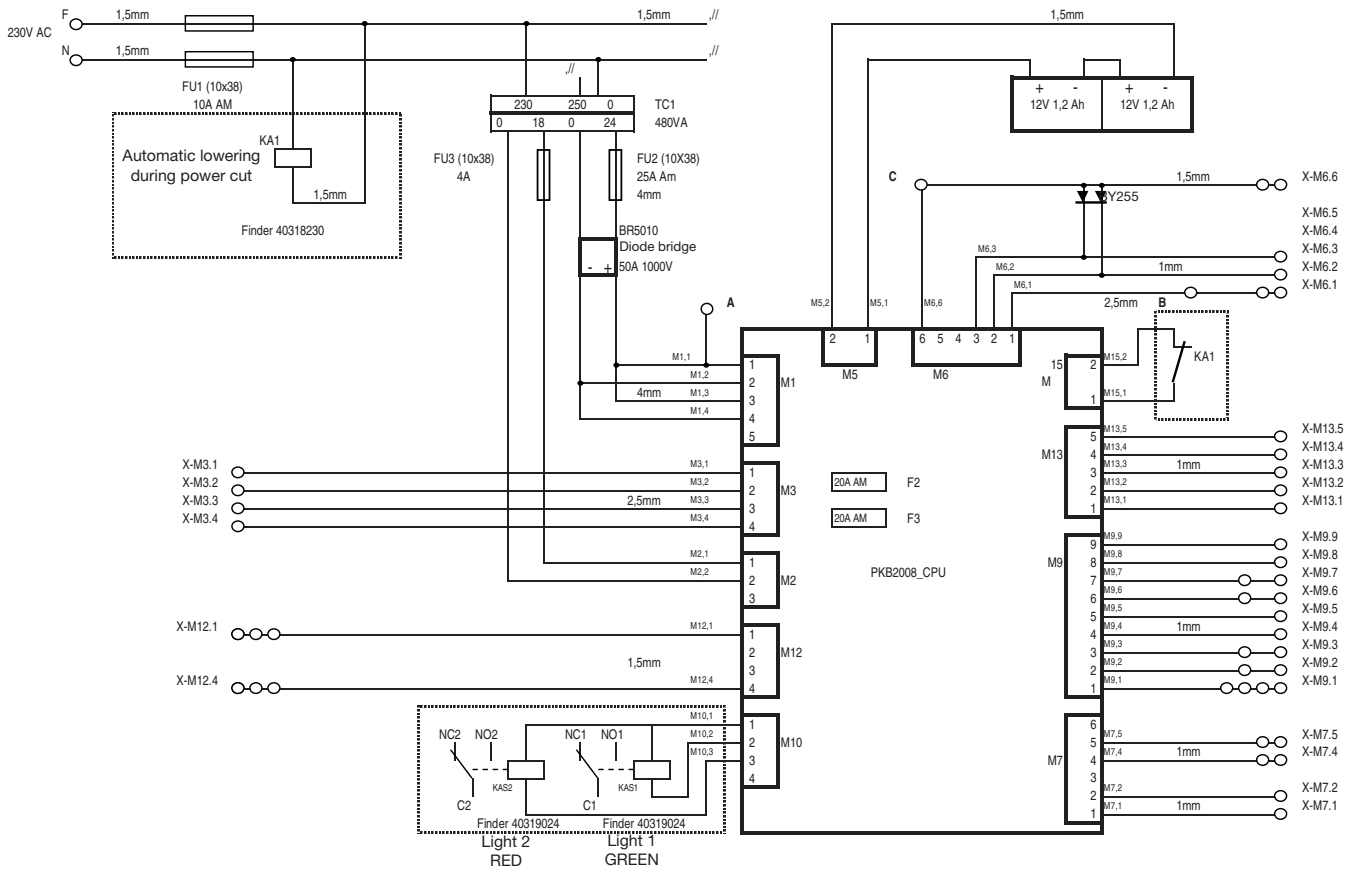

CP2K

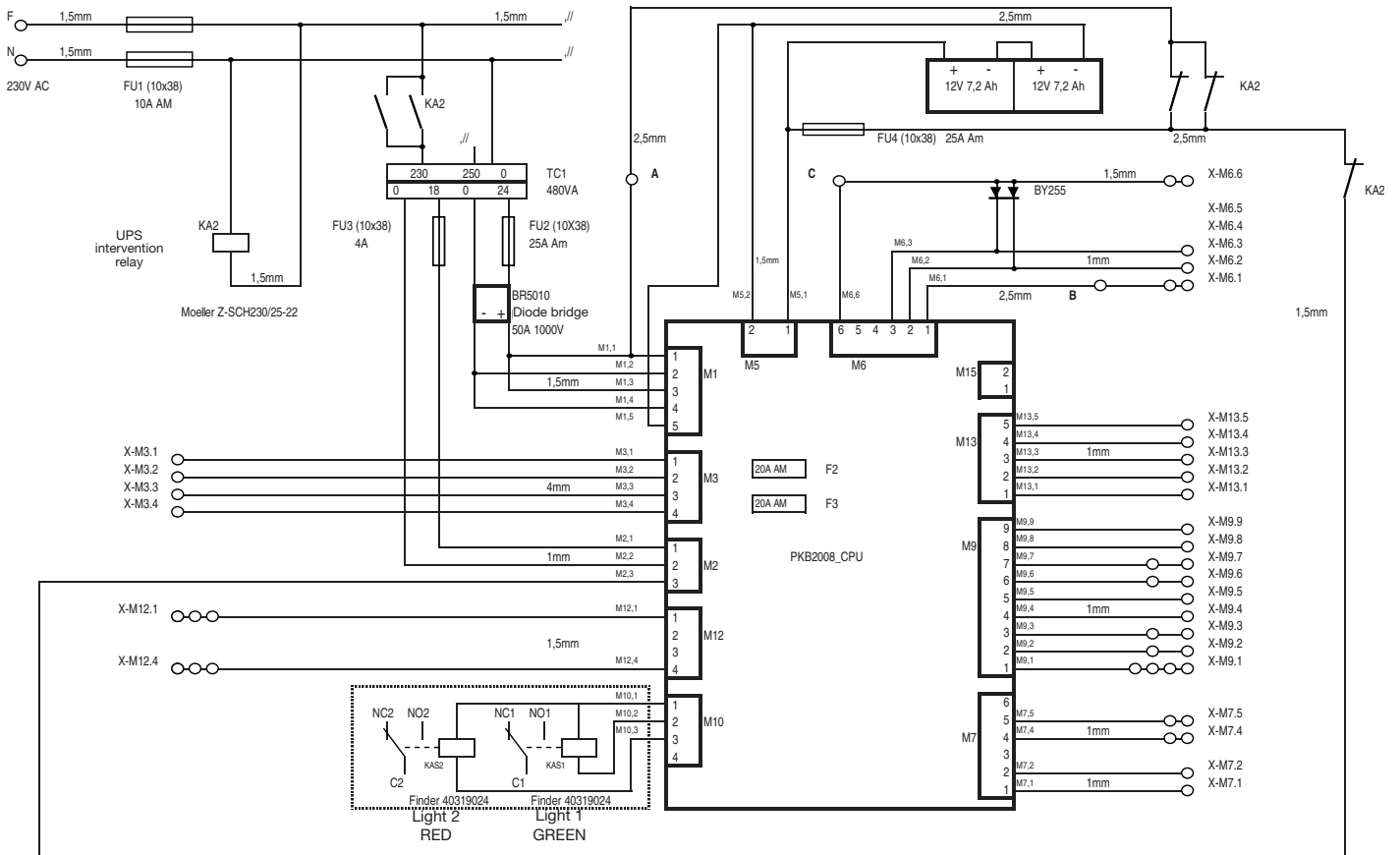

CP2S

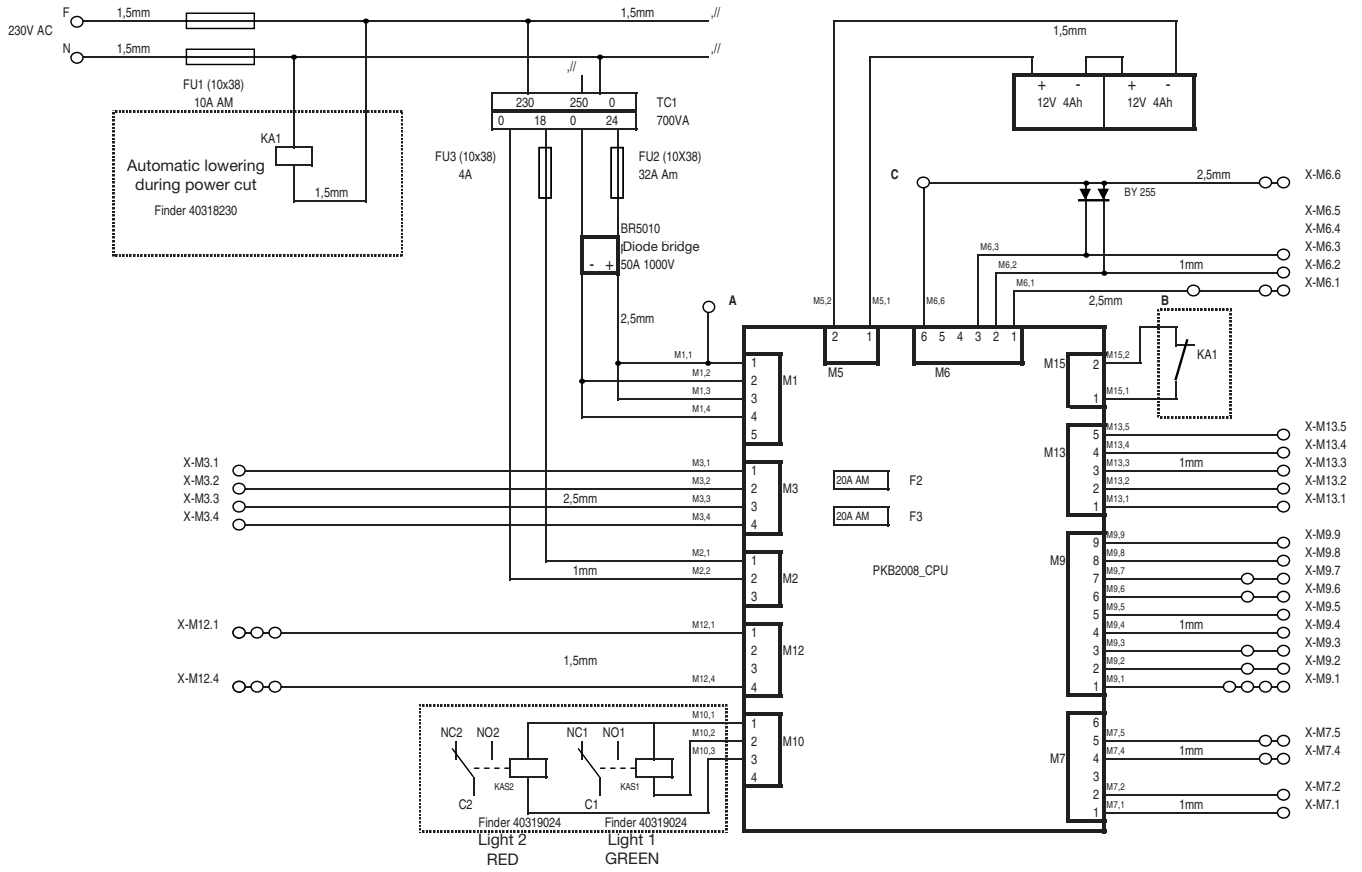

CP2SK

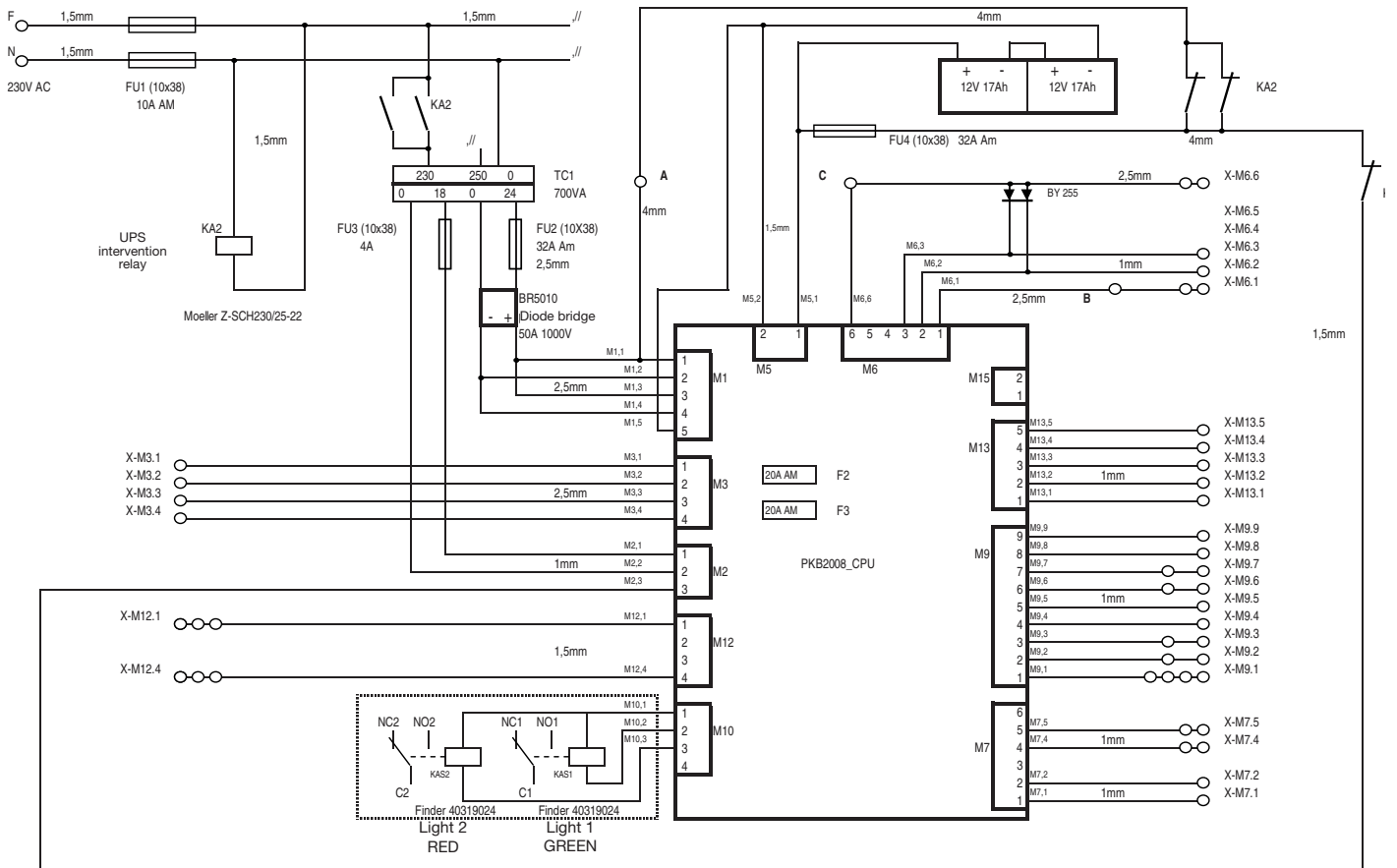



CP4

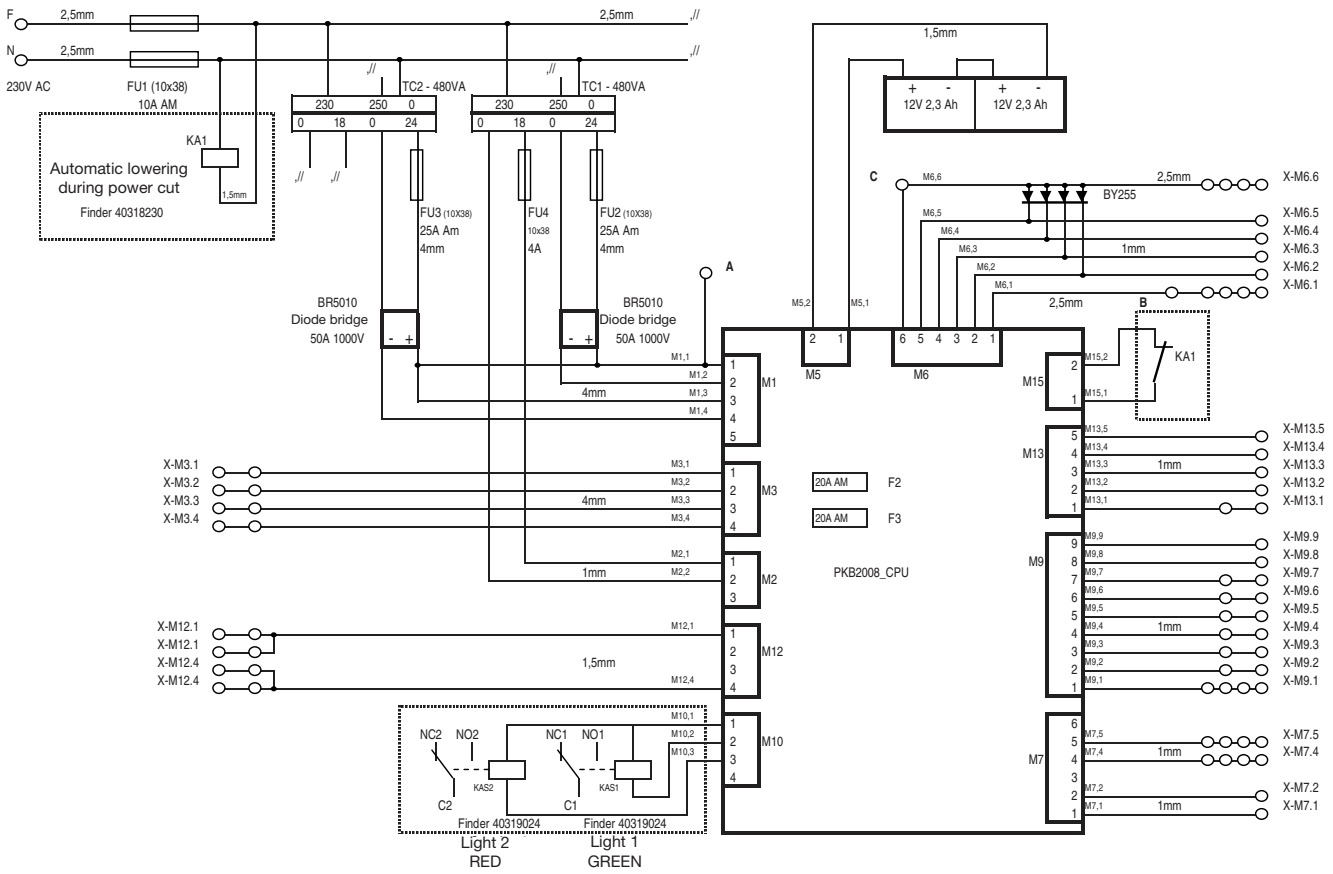

CP4K

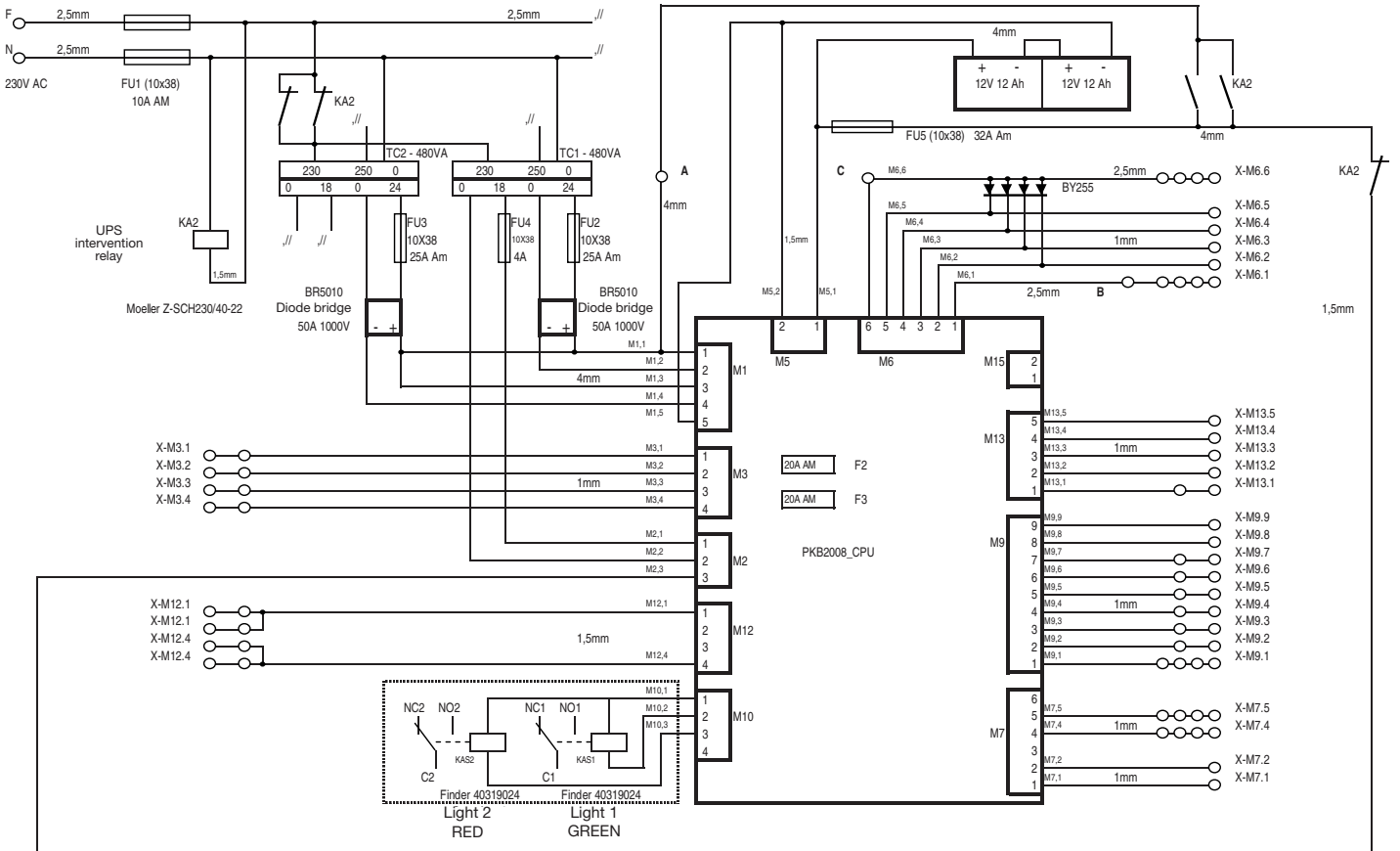

CP4S

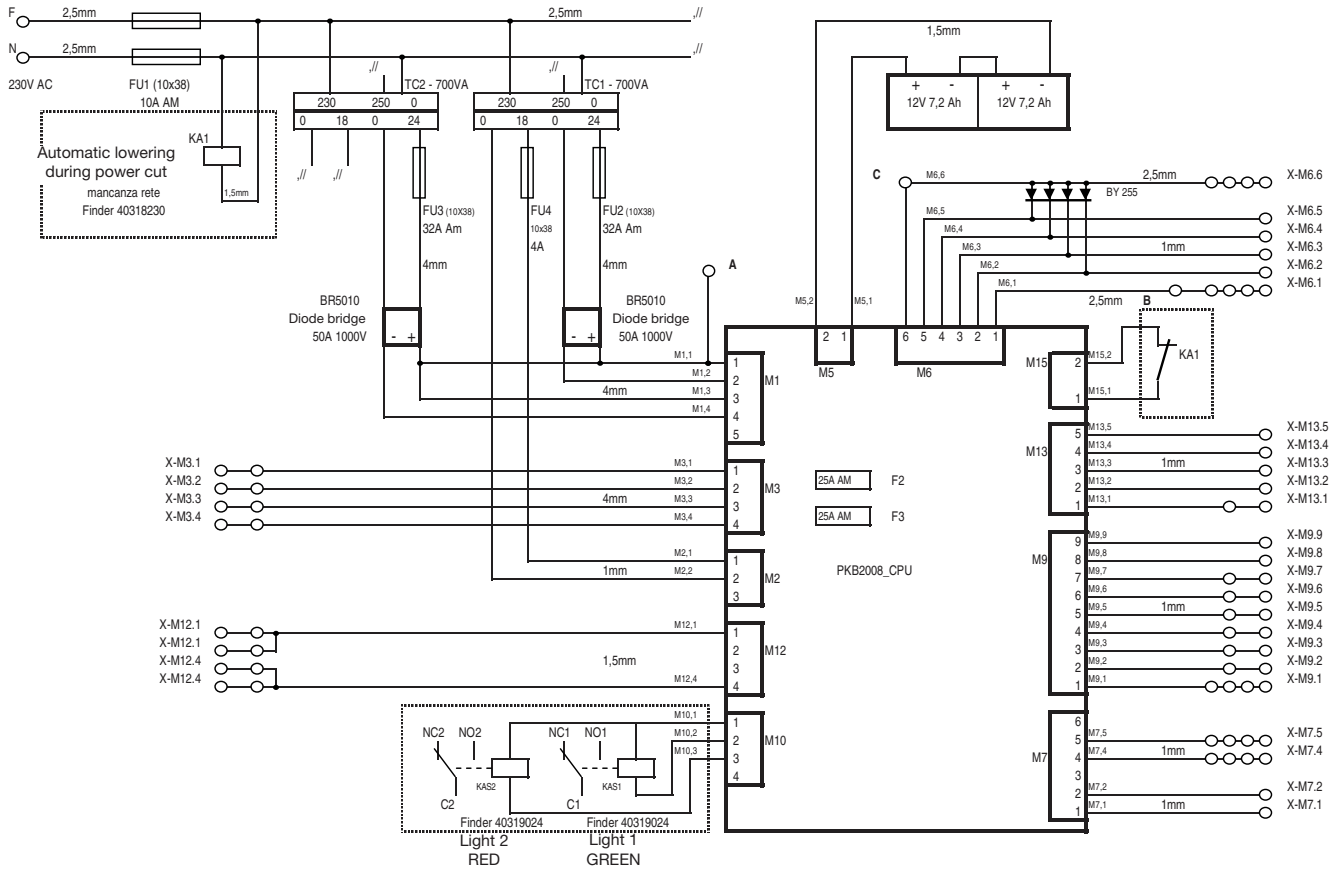

CP4SK

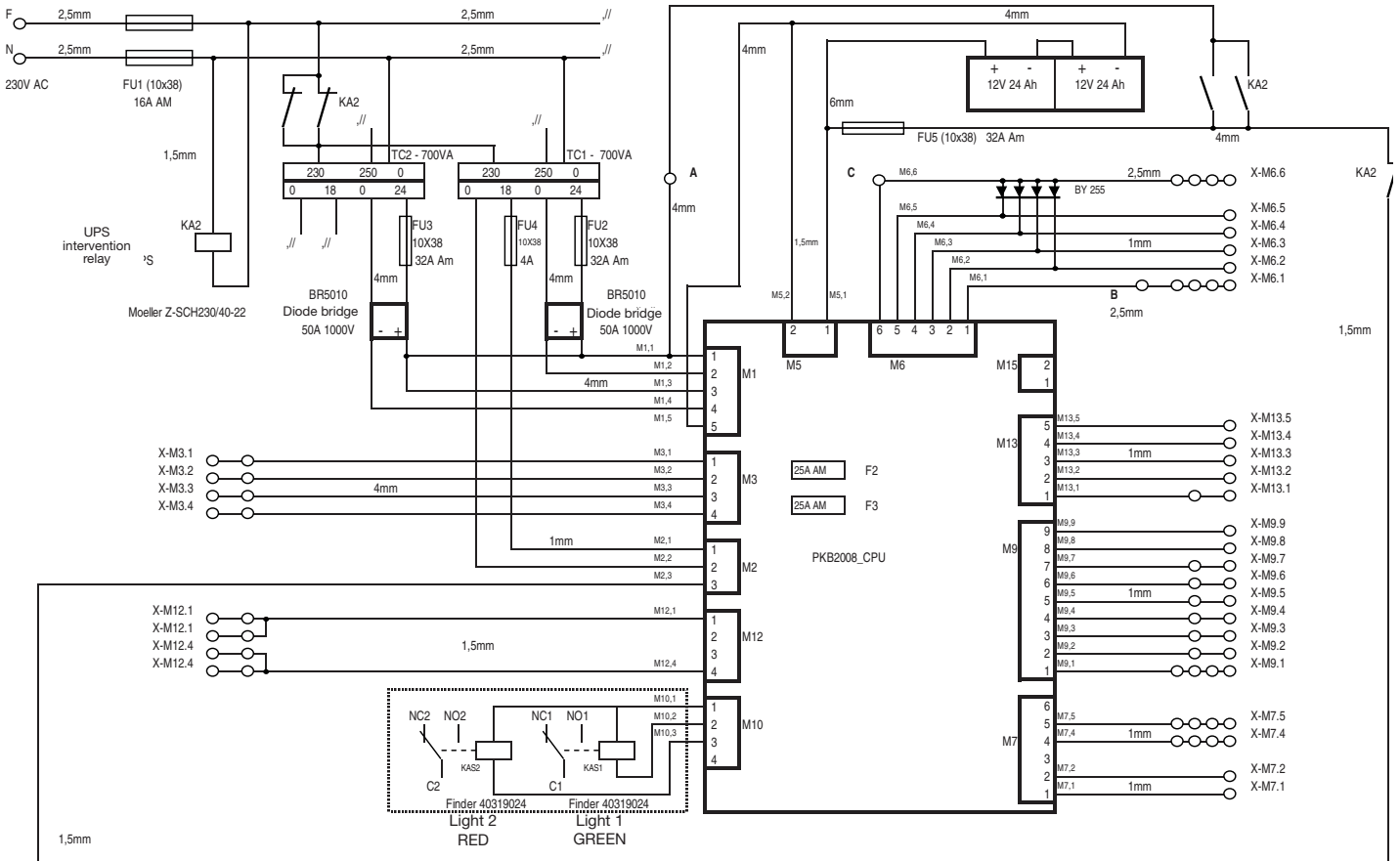

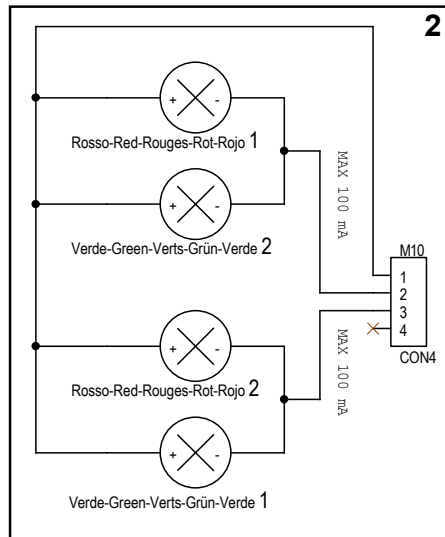
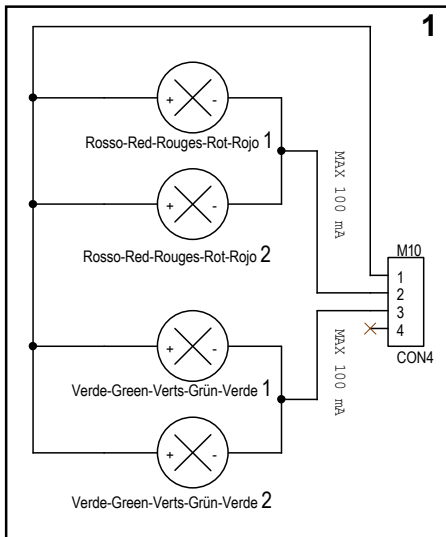
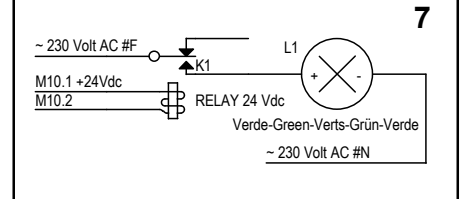
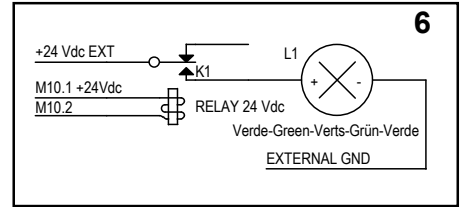
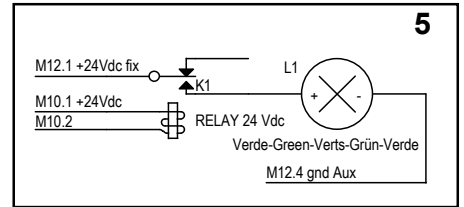
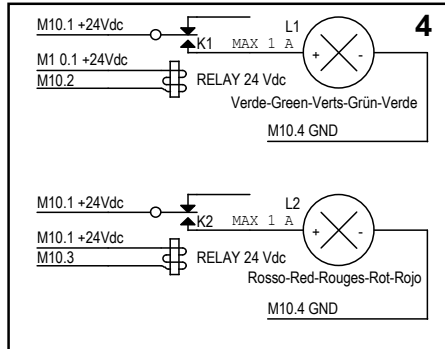
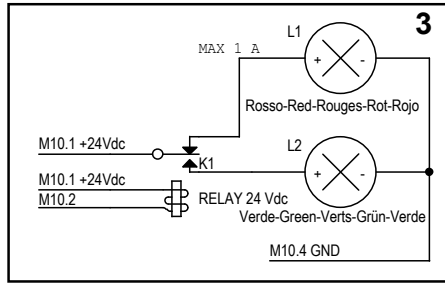
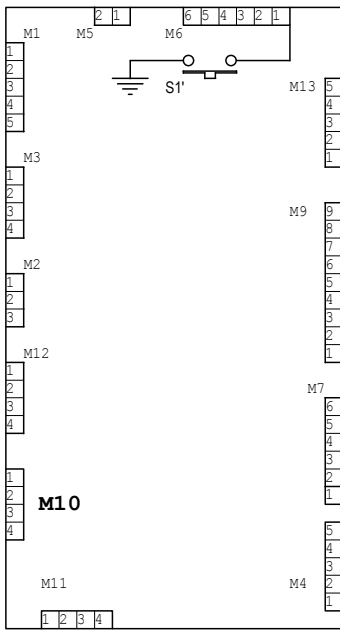

**M10 Terminal**

The output M10 can control one or more traffic lights in parallel (GREEN/ RED synchronized) or alternated passages(traffic light 1 Red/ Traffic light 2 Green or vice versa)

**S1 Push Button**

Input for emergency lowering in case of power failure.

**Diagram 1:**

Connecting of two traffic lights with low absorption (100 mA max) in parallel (GREEN1/GREEN2 or RED1/RED2).

**Diagram 2:**

Connecting of two traffic lights with low absorption (100 mA max) for alternated passages (GREEN1/RED2 or RED1/GREEN2).

**Diagram 3:**

Connection of one 24V 1A max traffic light powered by the CPU board with one switching relay.

**Diagram 4:**

Connection of two 24V 1A max traffic lights powered by the CPU board with two relays connected to the outputs GREEN/RED of the control board CPU.

**Diagram 5:**

Connection of two 24V traffic lights powered by the auxiliary output of the CPU board M12.1-12.4, controlled by the relay of the green output of the control board.

**Diagram 6:**

Connecting of 24V traffic lights powered separately, controlled by a relay connected to the GREEN output of the control board.

Connection of the RED light, the same as green light, M10.3 terminal.

**Diagram 7:**

Connection of one 230 V traffic light powered by main supply, controlled by a relay connected to the GREEN output of the control board.

Connection of the RED light, the same as green light, M10.3 terminal.

**Manual operation:**

When the bollard is down, the traffic light is green (M10.2: ON / M10.3: OFF).  
When the bollard starts raising, the traffic light becomes red (M10.2: OFF / M10.3: ON).  
At the beginning of lowering cycle, the traffic light remains RED, only once the bollard is completely down, the traffic light becomes green, according to the time set on TR2 trimmer (evacuation zone transit time).

**Automatic operation:**

Bollard lowered from global command (M9.6), when it is completely down, the traffic light becomes GREEN (M10.2: ON / M10.3: OFF) after the evacuation set time on TR2 Trimmer.

Approximately 3,5 seconds before starting the automatic raising cycle, the traffic light becomes RED (warning function), once the bollard is completely up, the traffic light remains RED (M10.2: OFF / M10.3: ON). Note: The warning of 3.5 seconds can be added to the pre-flashing time, adjustable by TR3 trimmer.

## CONNECTING TRAFFIC TLC2

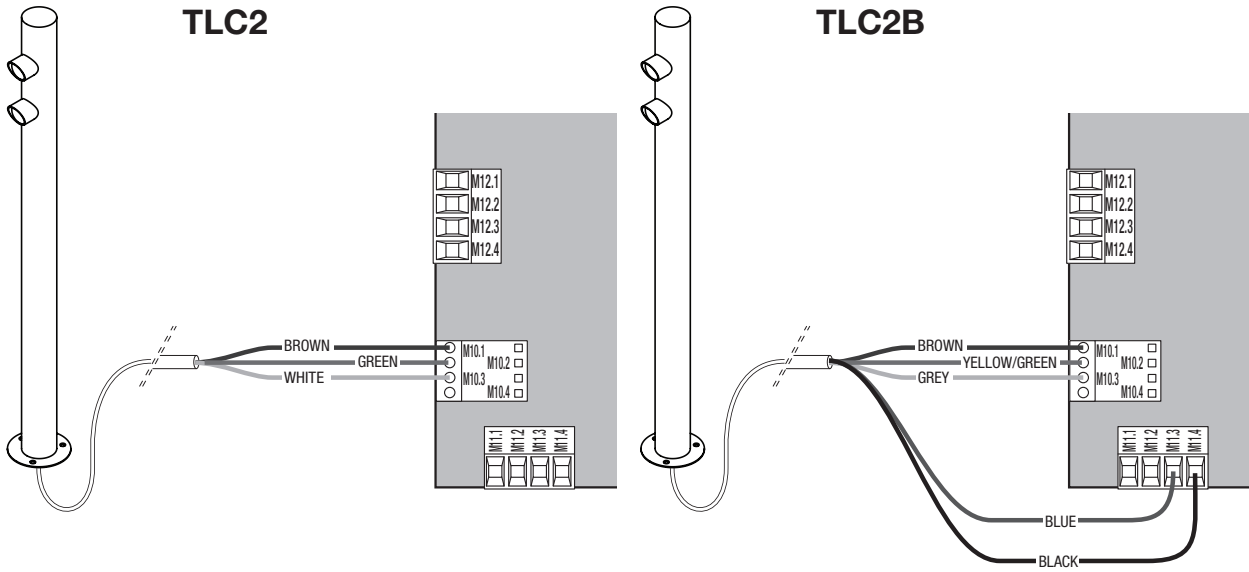

## DIMENSIONS AND CHARACTERISTICS OF THE CONTROL PANELS BOXES

**IP56 Protection Level**  
**Locking with metalscrews**

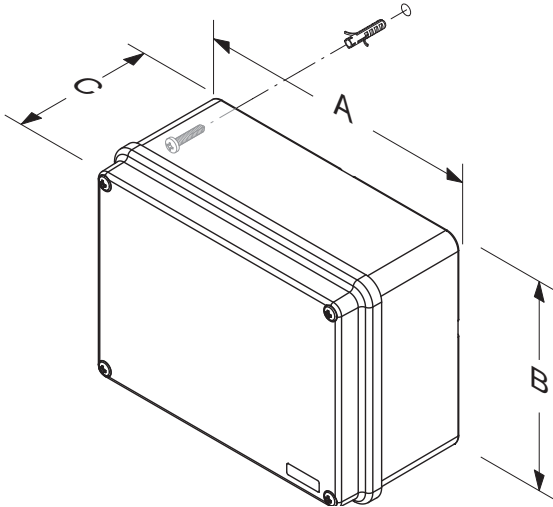

Dimensions (mm)			
Model	A	B	C
CP 1	300	220	120
CP 2	380	300	120
CP 4	460	380	120

IP68 Cable glands installed		
Model	Network Connection	Bollards Connection
CP 1	1 PG 13,5	1 PG 16
CP 2	1 PG 13,5	2 PG 16
CP 4	1 PG 13,5	4 PG 16

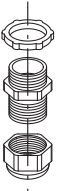

# RISE

■  
**Rising**  
**Bollards**  
**Evolution**