

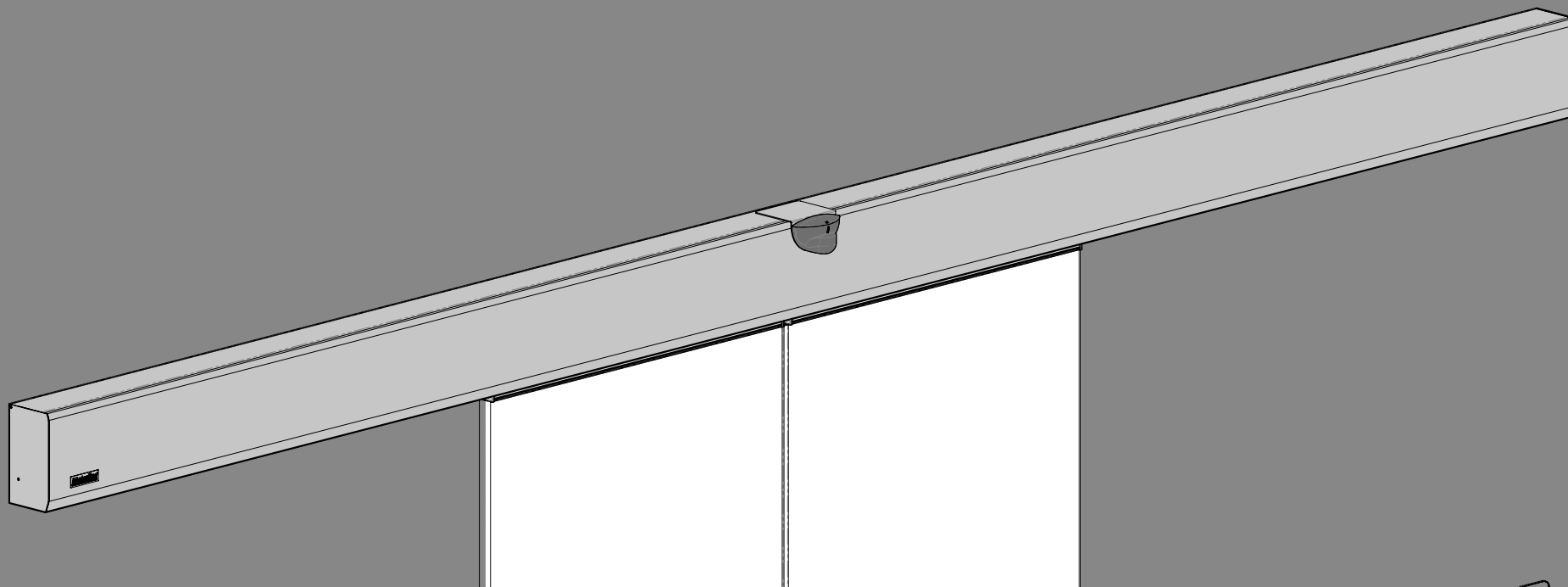

KAPVSP

USER'S / INSTALLER'S MANUAL



00. CONTENT

INDEX

01. SAFETY INSTRUCTIONS

STANDARDS TO FOLLOW 1B

02. CONNECTIONS SCHEME

SCHEME A - MR27 AND M1601 RADARS WITH PHOTOCELLS MODULE 4

SCHEME B - MR27 AND M1601 RADARS WITHOUT PHOTOCELLS MODULE 5

SCHEME C - 2 M1601 RADARS WITH PHOTOCELLS MODULE 6

SCHEME D - 2 M1601 RADARS WITHOUT PHOTOCELLS MODULE 7

SCHEME E - 2 MR27 RADARS WITHOUT PHOTOCELLS MODULE 8

03. THE DOOR

TECHNICAL CHARACTERISTICS 9A

DOOR COMPONENTS 9B

MEASURES 10A

UNLOCK 11B

04. INSTALLATION

PRE-INSTALLATION 11B

SAFE INSTALLATION 12A

GLASS INSTALLATION ON THE SAFE 14A

GUIDES INSTALLATION 15A

STOPPERS ADJUSTMENT 15B

COMPONENTS 16A

110V/230V CONNECTION 16A

SECURITY BATTERIES 16B

05. PROGRAMMING

CONTROL BOARD 17A

SELECTOR 19A

06. MAINTENANCE

BELT 20A

OTHER INFORMATION 20B

07. TROUBLESHOOTING

MALFUNCTION DIAGNOSIS 21

01. SAFETY INSTRUCTIONS

STANDARDS TO FOLLOW



This product is certified in accordance with European Community (EC) safety standards.



This product complies with Directive 2011/65/EU of the European Parliament and of the Council, of 8 June 2011, on the restriction of the use of certain hazardous substances in electrical and electronic equipment.



(Applicable in countries with recycling systems).
This marking on the product or literature indicates that the product and electronic accessories (eg. Charger, USB cable, electronic material, controls, etc.) should not be disposed of as other household waste at the end of its useful life. To avoid possible harm to the environment or human health resulting from the uncontrolled disposal of waste, separate these items from other types of waste and recycle them responsibly to promote the sustainable reuse of material resources. Home users should contact the dealer where they purchased this product or the National Environment Agency for details on where and how they can take these items for environmentally safe recycling. Business users should contact their vendor and check the terms and conditions of the purchase agreement. This product and its electronic accessories should not be mixed with other commercial waste.



This marking indicates that the product and electronic accessories (eg. charger, USB cable, electronic material, controls, etc.) are susceptible to electric shock by direct or indirect contact with electricity. Be cautious when handling the product and observe all safety procedures in this manual.

01. SAFETY INSTRUCTIONS

GENERAL WARNINGS

- This manual contains very important safety and usage information, very important. Read all instructions carefully before beginning the installation/usage procedures and keep this manual in a safe place that it can be consulted whenever necessary.
- This product is intended for use only as described in this manual. Any other enforcement or operation that is not mentioned is expressly prohibited, as it may damage the product and put people at risk causing serious injuries.
- This manual is intended firstly for specialized technicians, and does not invalidate the user's responsibility to read the "User Norms" section in order to ensure the correct functioning of the product.
- The installation and repair of this product may be done by qualified and specialized technicians, to assure every procedure are carried out in accordance with applicable rules and norms. Nonprofessional and inexperienced users are expressly prohibited of taking any action, unless explicitly requested by specialized technicians to do so.
- Installations must be frequently inspected for unbalance and the wear signals of the cables, springs, hinges, wheels, supports and other mechanical assembly parts.
- Do not use the product if it is necessary repair or adjustment is required.
- When performing maintenance, cleaning and replacement of parts, the product must be disconnected from power supply. Also including any operation that requires opening the product cover.
- The use, cleaning and maintenance of this product may be carried out by any persons aged eight years old and over and persons whose physical, sensorial or mental capacities are lower, or by persons without any knowledge of the product, provided that these are supervision and instructions given by persons with experienced in terms of usage of the product in a safe manner and who understands the risks and dangers involved.
- Children shouldn't play with the product or opening devices to avoid

the motorized door or gate from being triggered involuntarily.

WARNINGS FOR TECHNICIANS

- Before beginning the installation procedures, make sure that you have all the devices and materials necessary to complete the installation of the product.
- You should note your Protection Index (IP) and operating temperature to ensure that is suitable for the installation site.
- Provide the manual of the product to the user and let them know how to handle it in an emergency.
- If the automatism is installed on a gate with a pedestrian door, a door locking mechanism must be installed while the gate is in motion.
- Do not install the product "upside down" or supported by elements do not support its weight. If necessary, add brackets at strategic points to ensure the safety of the automatism.
- Do not install the product in explosive site.
- Safety devices must protect the possible crushing, cutting, transport and danger areas of the motorized door or gate.
- Verify that the elements to be automated (gates, door, windows, blinds, etc.) are in perfect function, aligned and level. Also verify if the necessary mechanical stops are in the appropriate places.
- The central must be installed on a safe place of any fluid (rain, moisture, etc.), dust and pests.
- You must route the various electrical cables through protective tubes, to protect them against mechanical exertions, essentially on the power supply cable. Please note that all the cables must enter the central from the bottom.
- If the automatism is to be installed at a height of more than 2,5m from the ground or other level of access, the minimum safety and health requirements for the use of work equipment workers at the work of Directive 2009/104/CE of European Parliament and of the Council of 16 September 2009.
- Attach the permanent label for the manual release as close as possible

01. SAFETY INSTRUCTIONS

to the release mechanism.

- Disconnect means, such as a switch or circuit breaker on the electrical panel, must be provided on the product's fixed power supply leads in accordance with the installation rules.
- If the product to be installed requires power supply of 230Vac or 110Vac, ensure that connection is to an electrical panel with ground connection.
- The product is only powered by low voltage safety with central (only at 24V motors)

WARNINGS FOR USERS

- Keep this manual in a safe place to be consulted whenever necessary.
- If the product has contact with fluids without being prepared, it must immediately disconnect from the power supply to avoid short circuits, and consult a specialized technician.
- Ensure that technician has provided you the product manual and informed you how to handle the product in an emergency.
- If the system requires any repair or modification, unlock the automatism, turn off the power and do not use it until all safety conditions have been met.
- In the event of tripping of circuits breakers or fuse failure, locate the malfunction and solve it before resetting the circuit breaker or replacing the fuse. If the malfunction is not repairable by consult this manual, contact a technician.
- Keep the operation area of the motorized gate free while the gate in motion, and do not create strength to the gate movement.
- Do not perform any operation on mechanical elements or hinges if the product is in motion.

RESPONSABILITY

- Supplier disclaims any liability if:
 - Product failure or deformation result from improper installation

use or maintenance!

- Safety norms are not followed in the installation, use and maintenance of the product.
- Instructions in this manual are not followed.
- Damaged is caused by unauthorized modifications
- In these cases, the warranty is voided.

SYMBOLS LEGEND:



• Important safety notices



• Useful information



• Programming information



• Potentiometer information



• Connectors information



• Buttons information

02. CONNECTIONS SCHEME

SCHEME A - MR27 AND M1601 RADARS WITH PHOTOCELLS MODULE

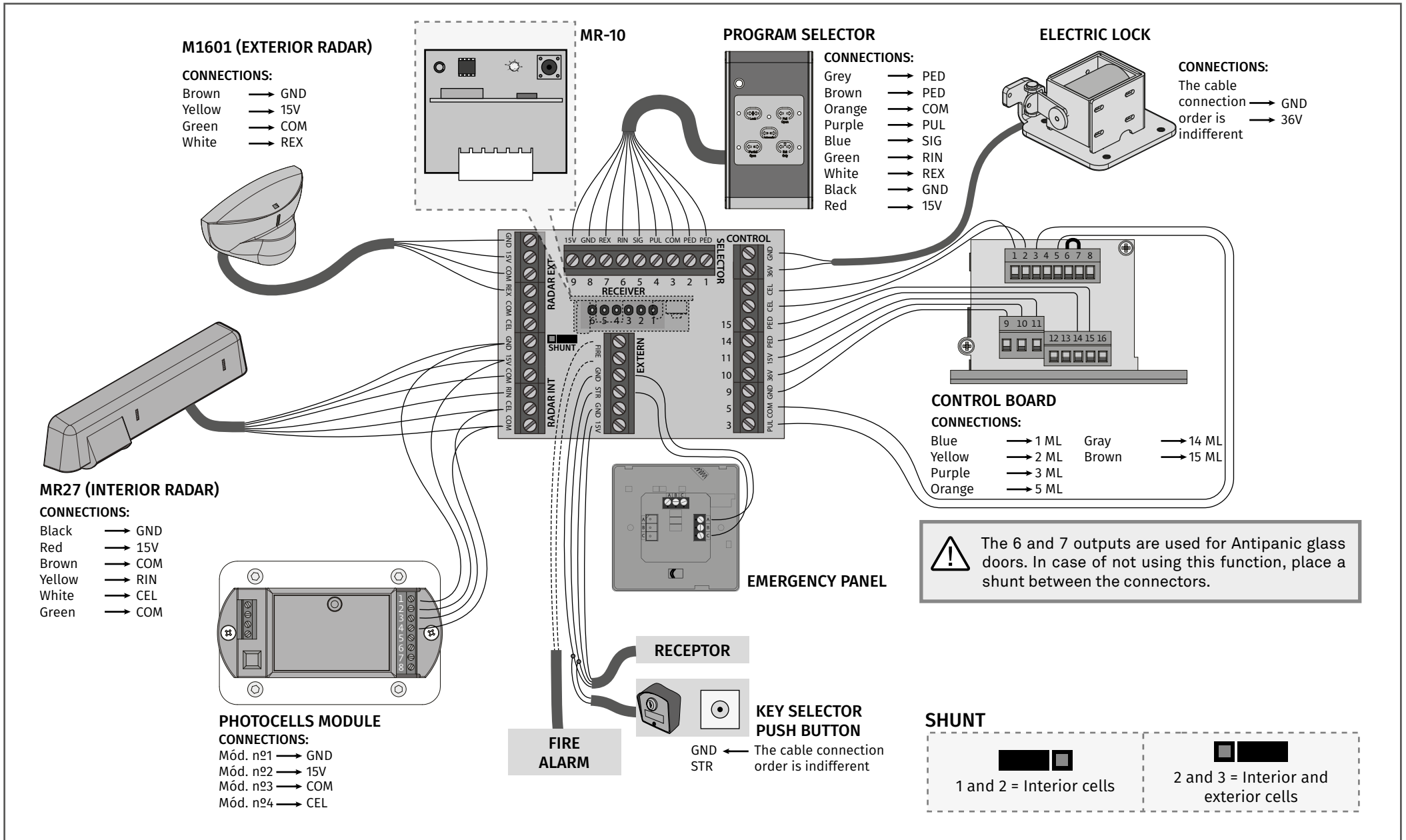

02. CONNECTIONS SCHEME

SCHEME B - MR27 AND M1601 RADARS **WITHOUT** PHOTOCELLS MODULE

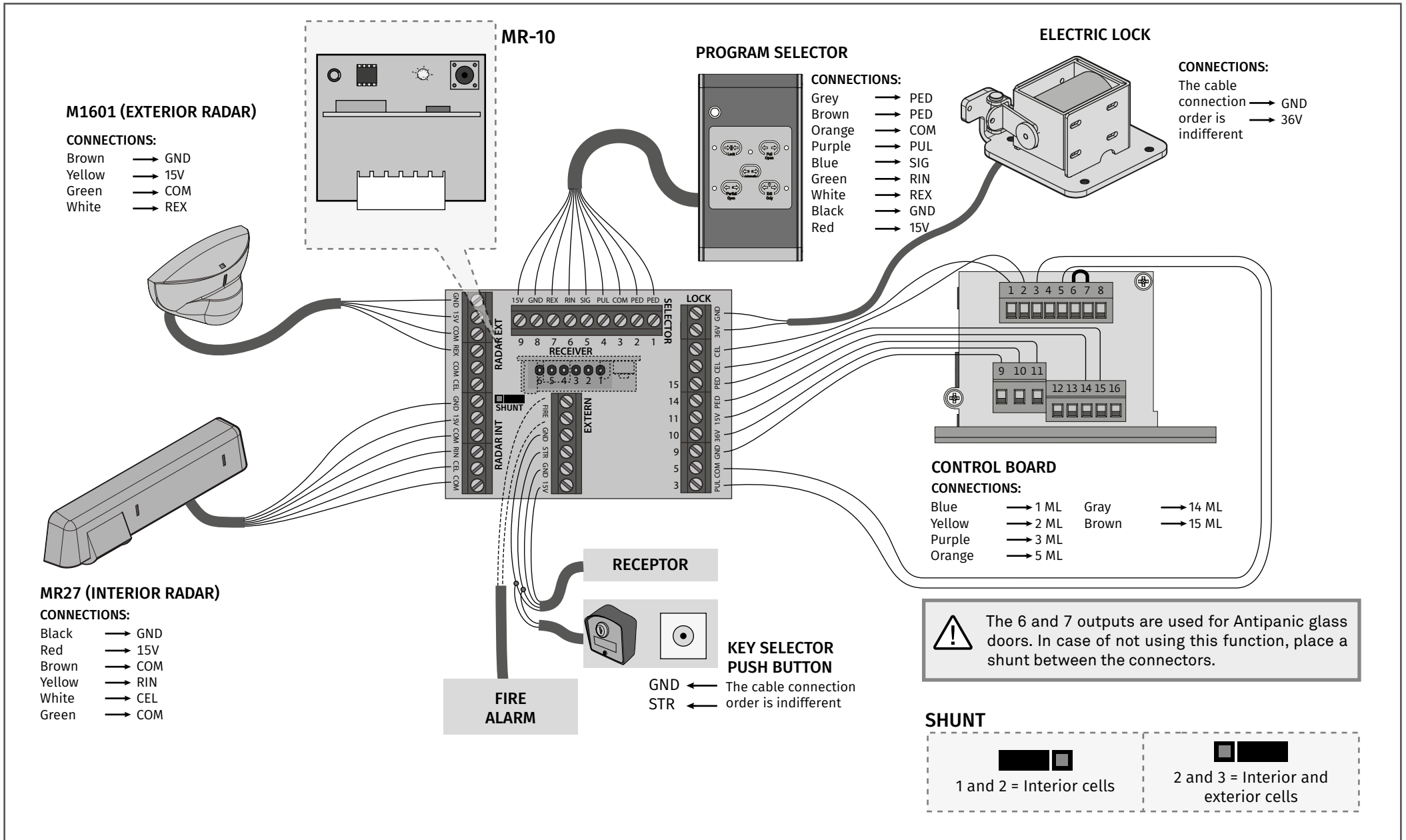

02. CONNECTIONS SCHEME

SCHEME C - 2 M1601 RADARS WITH PHOTOCELLS MODULE

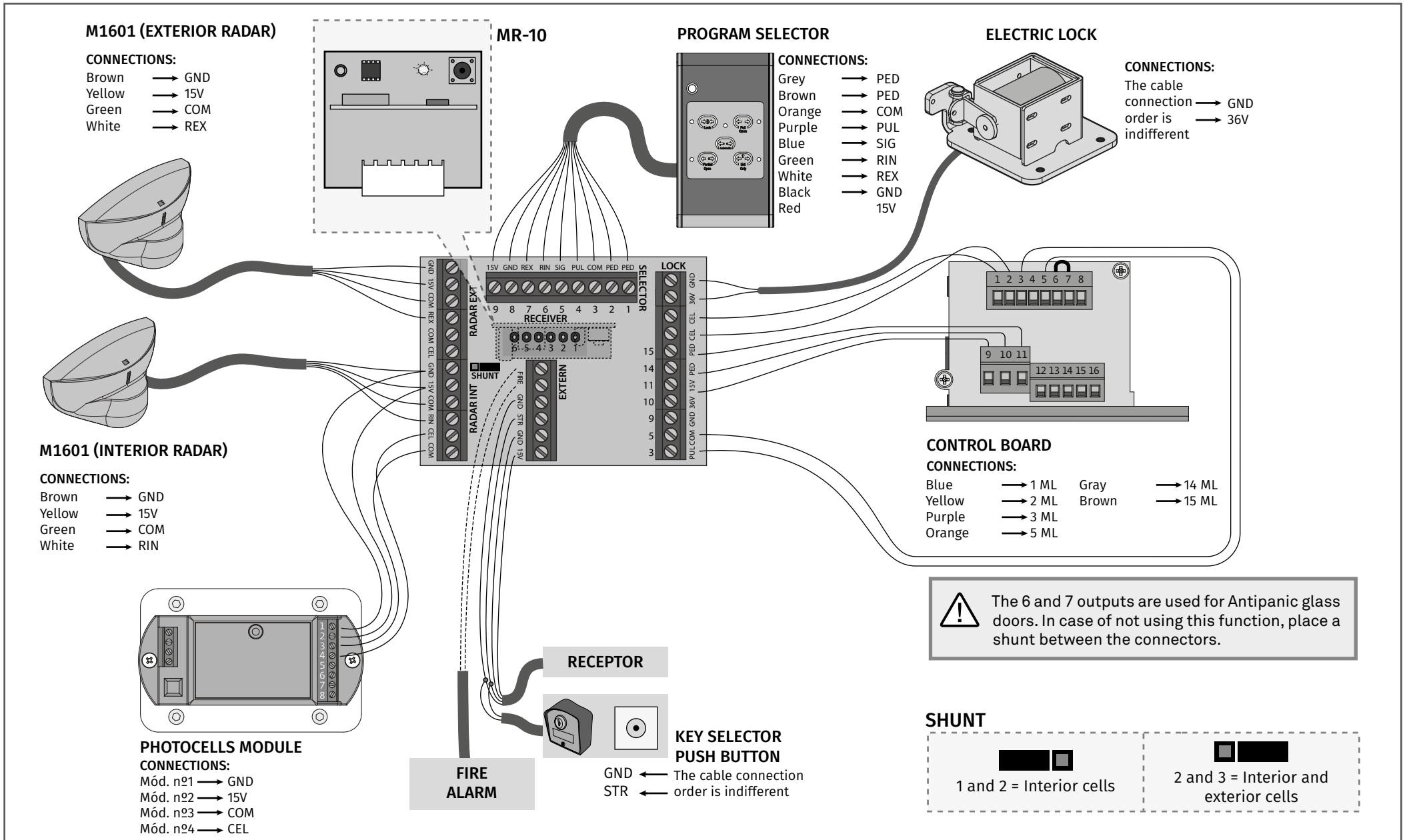

02. CONNECTIONS SCHEME

SCHEME D - 2 M1601 RADARS **WITHOUT** PHOTOCELLS MODULE

M1601 (EXTERIOR RADAR)

- CONNECTIONS:**
 Brown → GND
 Yellow → 15V
 Green → COM
 White → REX

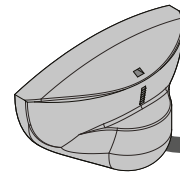
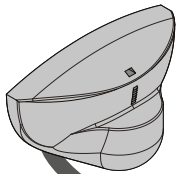

M1601 (INTERIOR RADAR)

- CONNECTIONS:**
 Brown → GND
 Yellow → 15V
 Green → COM
 White → RIN

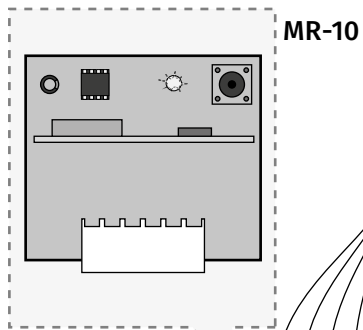

PROGRAM SELECTOR

- CONNECTIONS:**
 Grey → PED
 Brown → PED
 Orange → COM
 Purple → PUL
 Blue → SIG
 Green → RIN
 White → REX
 Black → GND
 Red → 15V

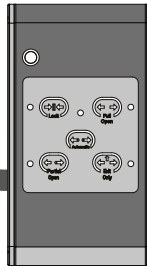

ELECTRIC LOCK

- CONNECTIONS:**
 The cable connection → GND
 order is → 36V
 indifferent

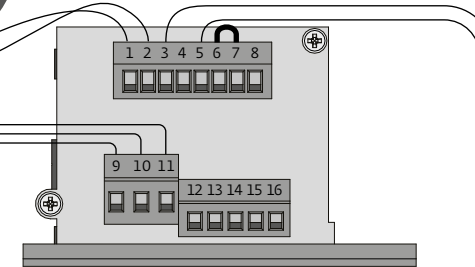
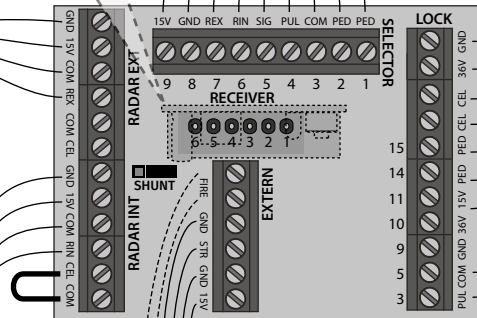
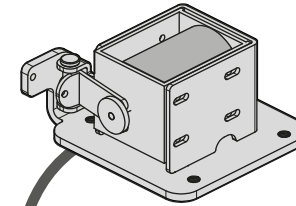

CONTROL BOARD

- CONNECTIONS:**
 Blue → 1 ML
 Yellow → 2 ML
 Purple → 3 ML
 Orange → 5 ML
 Gray → 14 ML
 Brown → 15 ML

RECEPTOR

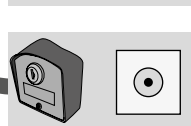

FIRE ALARM

KEY SELECTOR PUSH BUTTON

- GND ←
 STR ←
 The cable connection order is indifferent

! The 6 and 7 outputs are used for Antipanic glass doors. In case of not using this function, place a shunt between the connectors. If you do not use photocells and MR27 Radar, put a shunt in connectors 1 and 2.

SHUNT



02. CONNECTIONS SCHEME

SCHEME E - 2 MR27 RADARS **WITHOUT** PHOTOCELLS MODULE

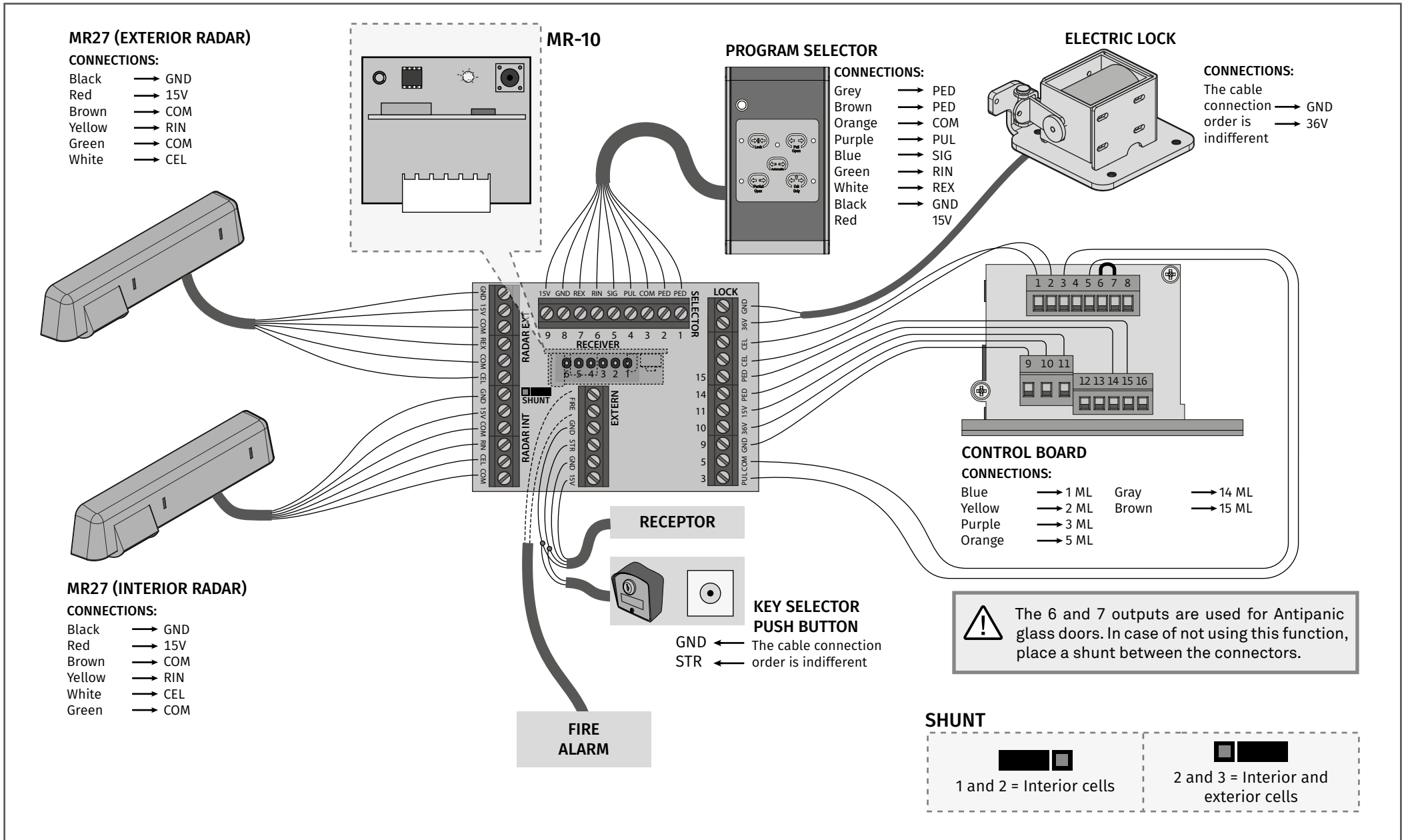

03. THE DOOR

TECHNICAL CHARACTERISTICS

With its automatic sliding system, the glass door KAPVSP is the perfect solution for the access of buildings where you want constant sound and climate isolation. This door is designed for intensive and continuous daily use.

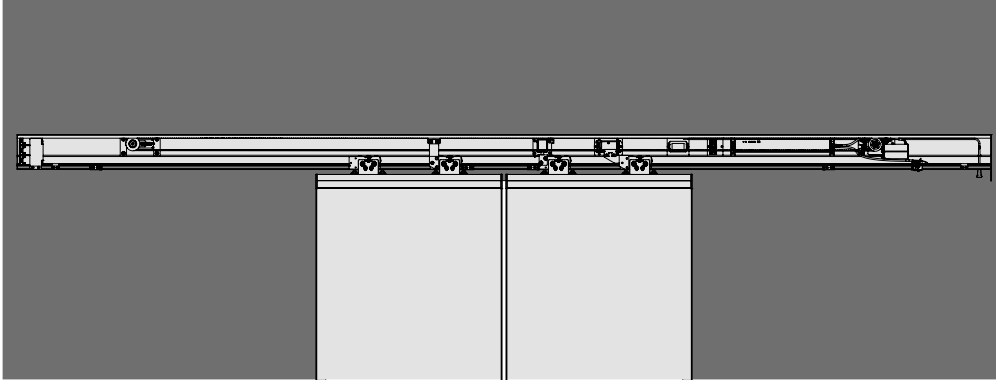

The characteristics of **Glass Door KAPVSP** are the following:

• Door type	1 leaf	2 leaves
• Leaf Weight	250kg Max.	125kg/leaf Max.
• Leaf Width	DW = 700~2000mm	DW = 650~1500mm
• Use Type	Intensive use	
• Installation types	Surface mounting	
• Power Supply	AC230V +/- 10%, 50~60Hz	
	AC110V (110V to 230V transformer) +/- 10%, 50~60Hz	
• Opening speed	300~500 mm/s (Ajustável)	
• Closing speed	250~500 mm/s (Ajustável)	
• Decreasing time	< 1s	
• Pause time	1~20s (Adjustable)	
• Anti-Wind strength	> 70N	
• Electronic lock strength	800N Approximately	
• Motor power	100W	
• Standby Power Consumption	10W Approximately	
• Functions (Selector)	• Always Closed • Always open • Partial opening (Auto mode.) • Full opening (Auto Mode.) • Only Exit	
• Operating temperature	-25°C ~ 50°C	

03. THE DOOR

TECHNICAL CHARACTERISTICS

You can find on the door the following components:

- A • Safe - front profile
- B • Safe - rear profile
- C • Carts*
- D • Belt
- E • Motor
- F • Belt Stretcher
- G • FOTO9S1A H Photocells (Optional)
- H • Photocells Module (Optional)
- I • Control board
- J • 3 Batteries
- K • MR27 Radar (Optional)
- L • M1601 Sensor (Optional)
- M • Selector (Optional)
- N • Electric lock (Optional)
- O • Guides*
- P • Stoppers
- Q1 • Grip Glass Fixation*
- Q2 • Drilling Glass Fixation*
- R • Upper Support*
- S • Bottom Support*
- T • Switch
- U • Accessory Kit*
- V • Connections board-PCB

* The amount depends on the size and/or quantity of the leaves.

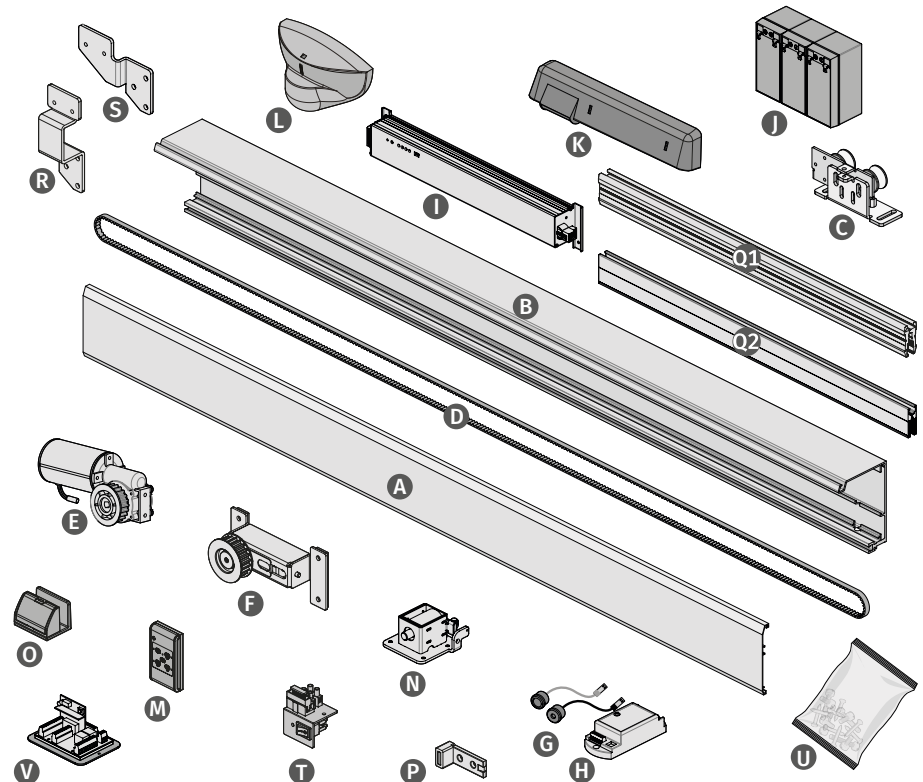

03. THE DOOR

MEASURES

• STANDARD GRIPPER

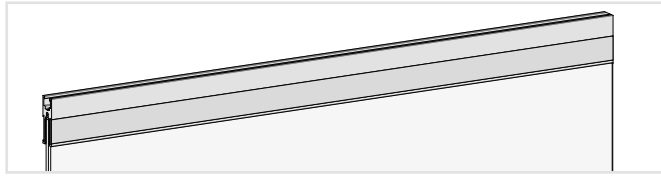
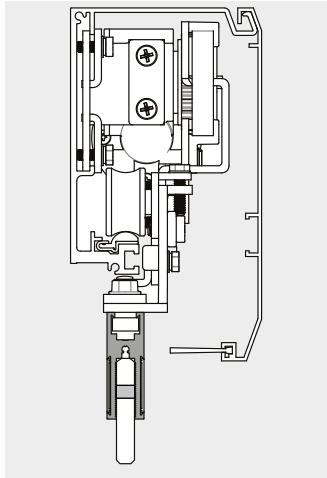

• GLASS FOR STANDARD GRIPPER

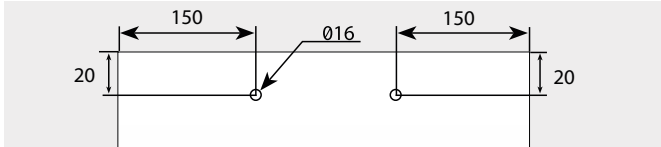

Standard gripper • To allow the gripper to hold the glass, it is required to make the holes as referenced above.

• GLASS DOOR'S LINTEL WITH STANDARD GRIPPER

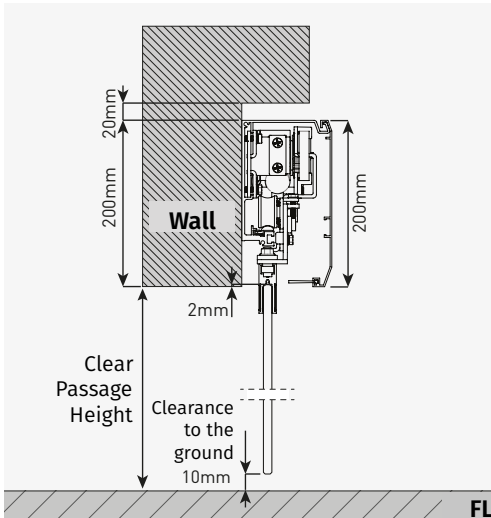

Semi-visible mode • Glass fixing profile stays slightly visible from the outside (220mm of minimum lintel).

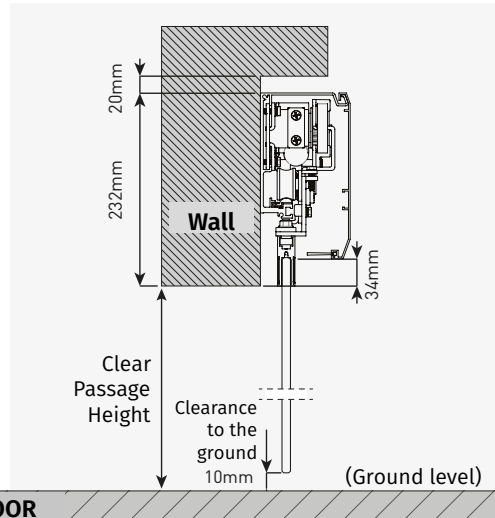

Invisible mode • Glass fixing profile stays hidden behind the lintel (252mm of minimum lintel).

03. THE DOOR

MEASURES

• TIGHTENING GRIPPER

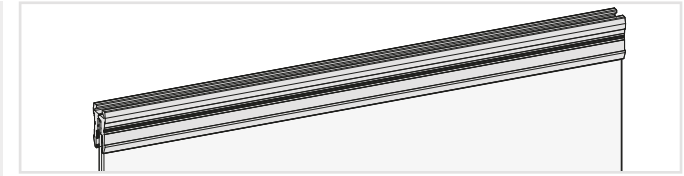
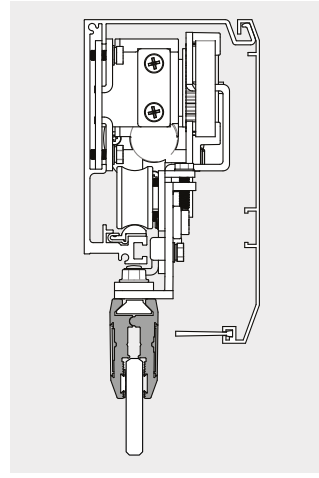

• GLASS FOR TIGHTENING GRIPPER



Tightening gripper • In the use of tightening gripper, the glass has no holes, wherein the fixing is achieved by putting screws in the grippers only.

• GLASS DOOR'S LINTEL WITH TIGHTENING GRIPPER

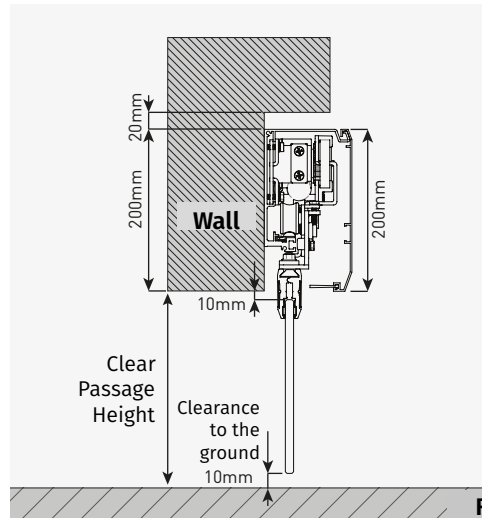

Semi-visible mode • Glass fixing profile stays visible from the outside (220mm of minimum lintel).

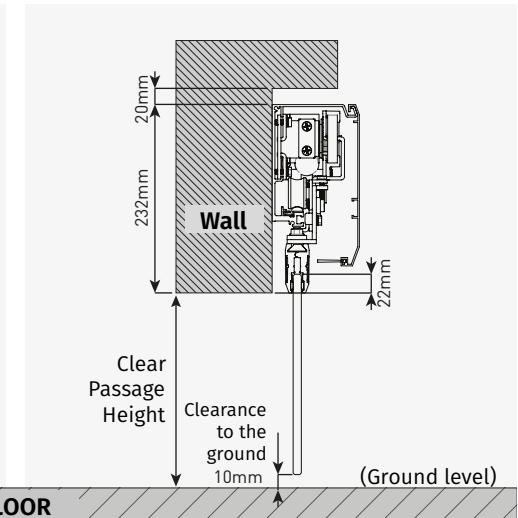

Invisible mode • Glass fixing profile stays hidden behind the lintel (252mm of minimum lintel).

03. THE DOOR

MEASURES

• GLASS WITH ALUMINUM FRAME (MOBILE)

Leaf Width:
45mm(frame)+Leaf width+45mm(frame)

Leaf height:
70mm (frame)+Leaf height+45mm(frame)

⚠ ATTENTION: The aluminum frames from the fixed leaves presents different measures of moving leaves. The measure is 45mm in all profiles.

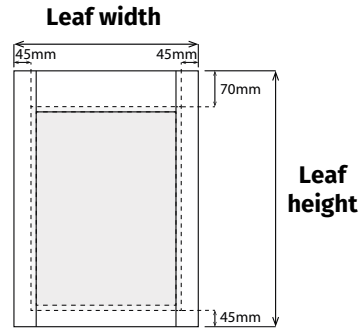

• LINTEL FOR GLASS DOOR WITH ALUMINUM FRAME

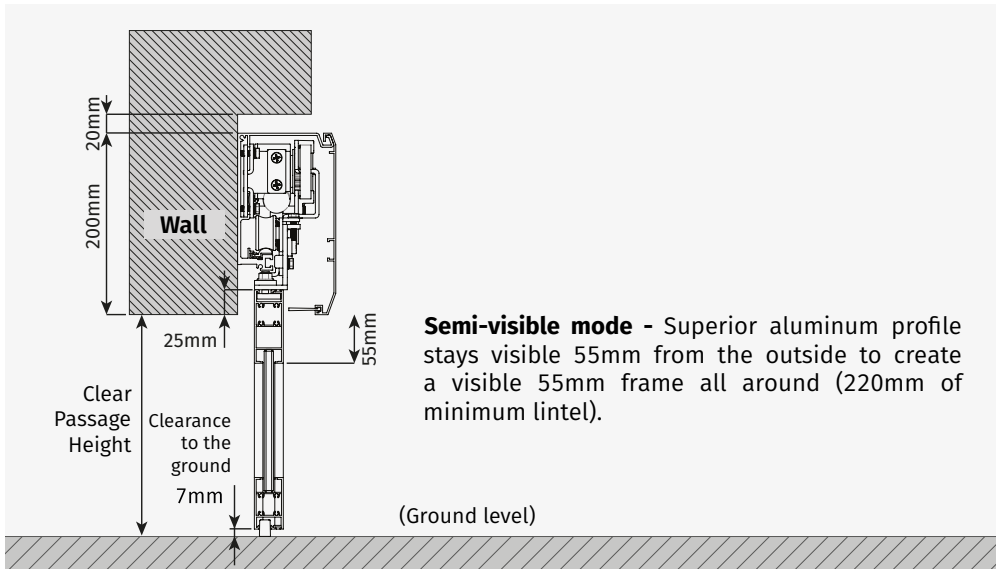

03. THE DOOR

UNLOCK

• ELETRIC LOCK

The electric lock is a security system that creates an automatic lock of the glass doors thus preventing burglary and increasing the safety of the space.

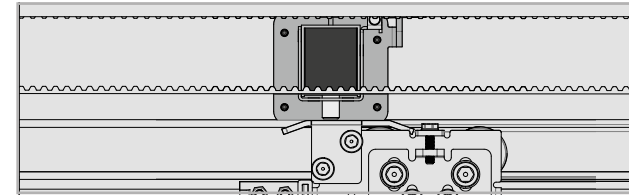

After triggered (door locked), the electric lock can be unlocked by pulling the safety lever down.

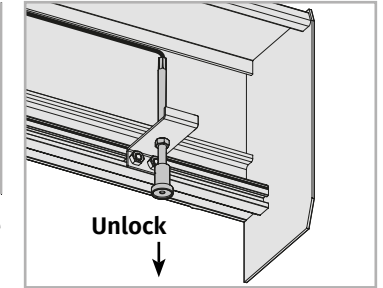

04. INSTALLATION

PRE-INSTALLATION

• PRE-INSTALLATION CONDITIONS AND VERIFICATIONS

- Make sure that the surface which is going to receive the door is level and upright.
- Floors should be smooth, uniform and level.
- The site should be free from shock and vibration.
- Check that the ambient temperature values are admissible for operation of this door.
- Perform the entire installation with the power off.
- Consult the manufacturer's instructions of all components to install.

• GENERAL INSTALLATION LOCATION

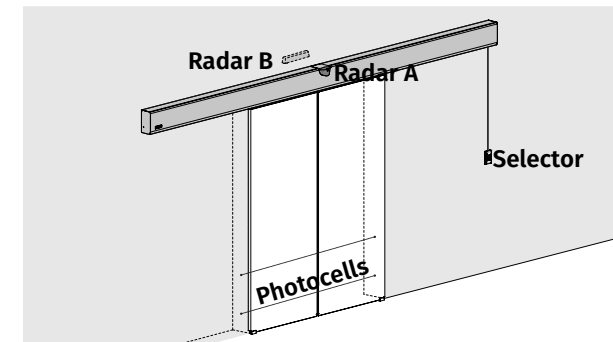

04. INSTALLATION

SAFE INSTALLATION

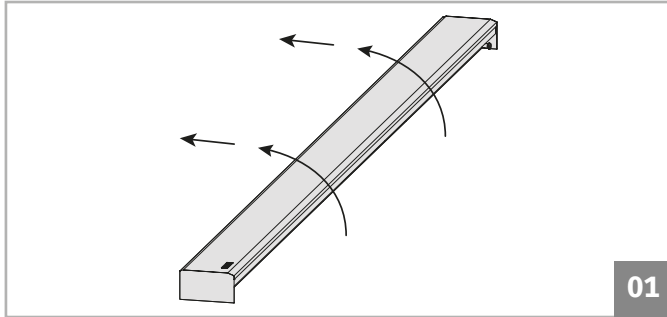

01

01. Place the safe under a protective material (card). Lift the safe's cover and slide it forward so it unhook from the safe, as shown above in **DETAIL (01.A)**. Remove all the loose components inside the safe as fixtures, receivers and carts.

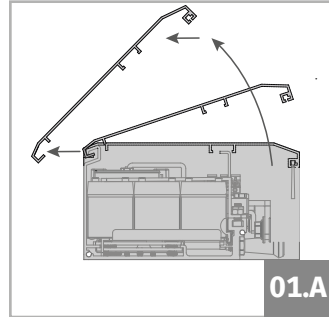

01.A

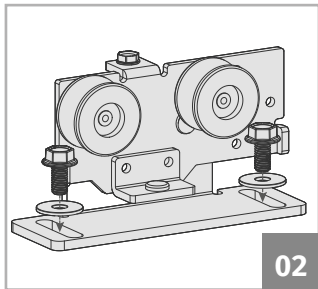

02

02. Apply the screws and washers that are in the accessory kit.

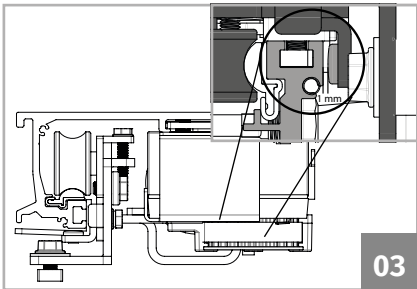

03

03. Slightly loosen the screws marked in **03.A** image and apply (s) stand (s) in the safe. Slide the small profile with rubber on the inside of the cart closer to the safe, leaving the rubber 1mm safe (03).

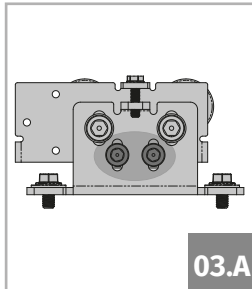

03.A

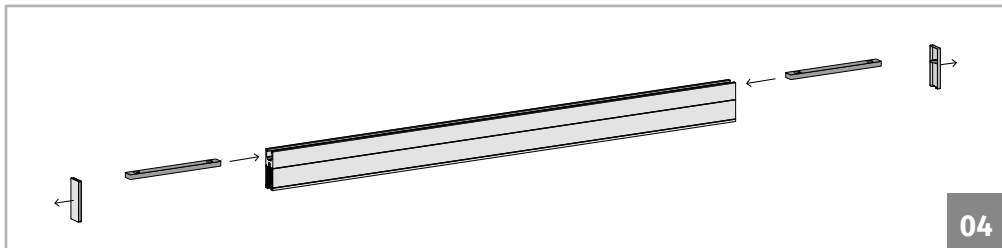

04

04. Remove the grippers caps and place the plates that are in the kit (each gripper requires two or three plates depending on the size of the leaf).

04. INSTALLATION

SAFE INSTALLATION

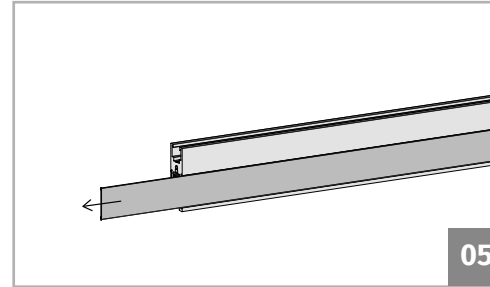

05

05. When using a standard gripper, slide the gripper's cover to access the holes.

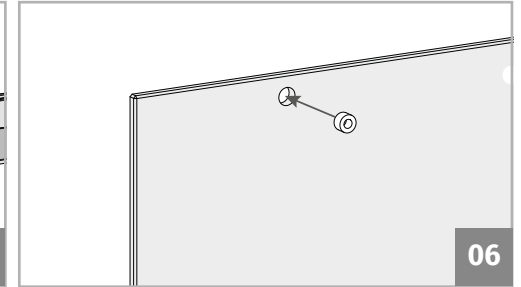

06

06. Apply the nylon washers in the existing holes of the glass.

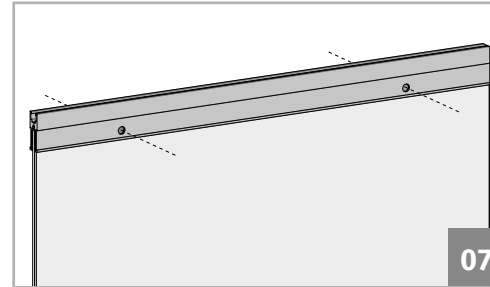

07

07. Direct the glass holes with the existing holes of the grippers. This operation must be performed on the ground, on top of a protective support (card).

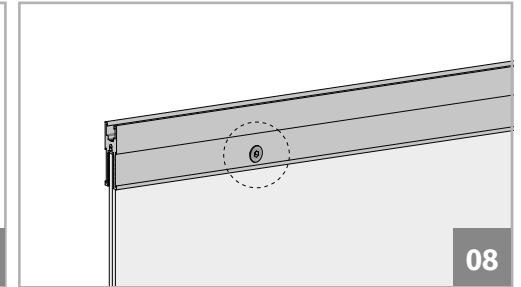

08

08. Apply the screw on the side where this is embedded in the profile. Also apply the nut on the other side and tighten the screw.

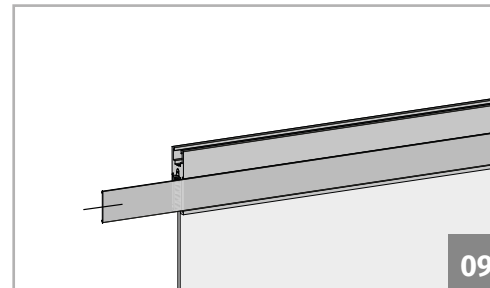

09

09. Refit the gripper cover.

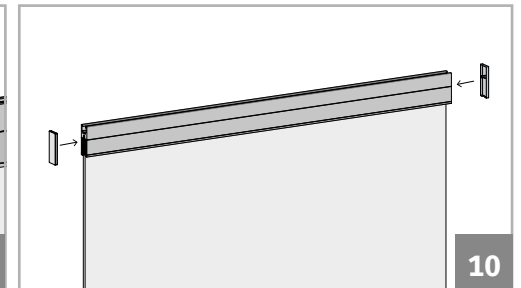

10

10. Place the caps so that the covers do not slip and fall.

04. INSTALLATION

SAFE INSTALLATION

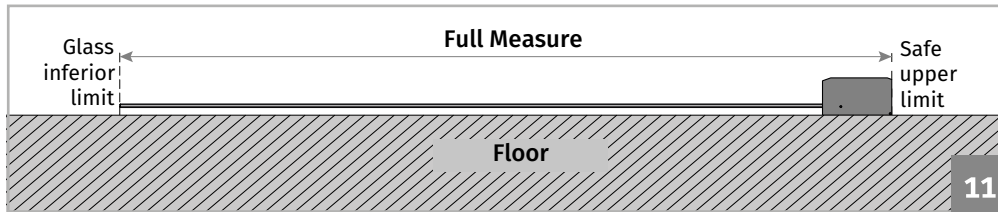

11. Also on the ground, touch the glass (with the gripper already on place) to the safe. Take the full measure of the glass lower limit to the upper limit of the safe. Keep attention to the leveling.

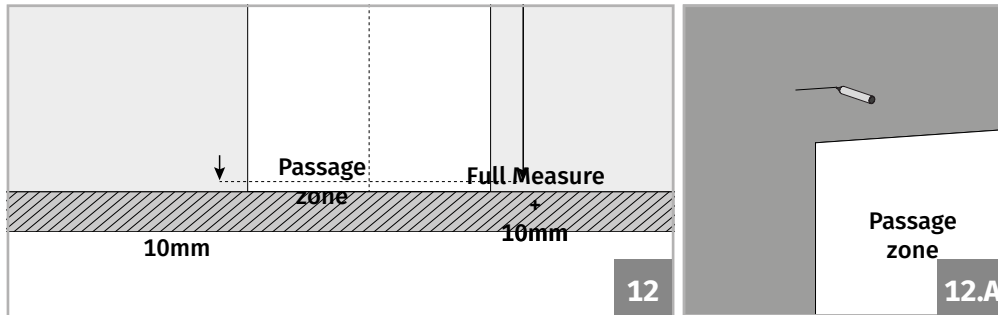

12. Transport and center the full measure to the location where it will be applied to door using a scribe material. Add 10mm to the full extent, leaving a margin so that the glass does not touch the floor. Make at least two marks, bearing in mind the leveling of the automation.

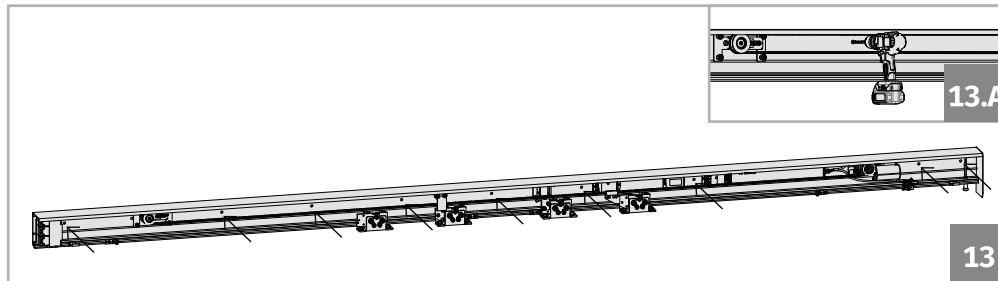

13. Make holes in the safe. The holes on the limits of the safe must be diverted 50mm from the safe's lateral tops if possible, while the remaining holes should be between 350 and 400 mm apart. The holes must be made in the area indicated on the image.



Please be aware of the released swarfs during drilling. These should be removed from within the automation to avoid damaging / conditioning the operation of the components.

04. INSTALLATION

SAFE INSTALLATION

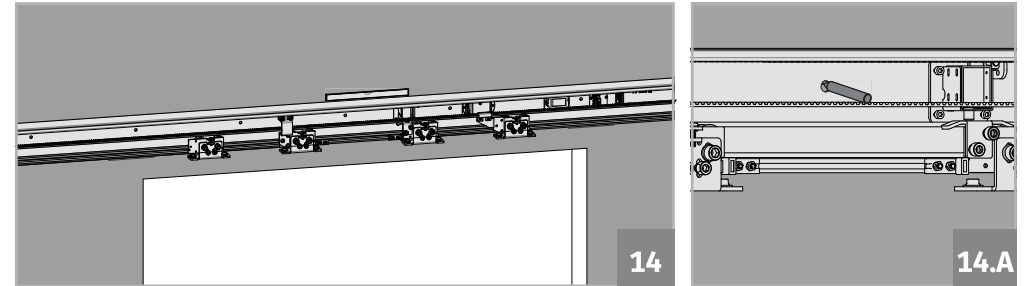

14. Put the safe against the wall and, using scribe material, do the markings on the exact locations where the safe was pierced. Keep attention to the safe leveling when you make the markings.

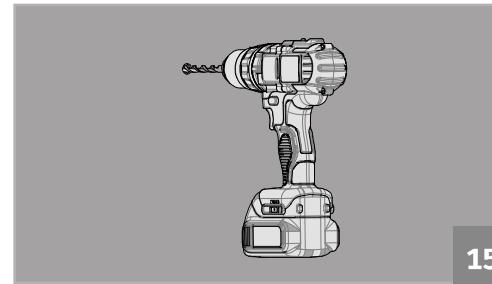

15. Make holes with xmm in the locations marked on the wall.

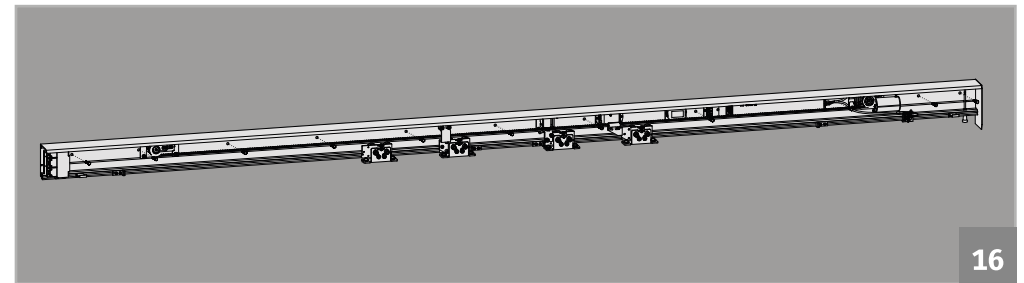

16. Refit the safe in the wall and apply the most suitable fixing to the surface that will receive it. Review the automatism cleanliness.

Surface	Fixation
Concrete / stone	Plastic Bushing
Concrete / stone	Metallic Bushing
Brick	Chemical Bushing
Metal	Self-Drilling Screw

04. INSTALLATION

GLASS INSTALLATION IN SAFE



17

17. Lift the glass and put it under the door, lined with carts that will hold it.

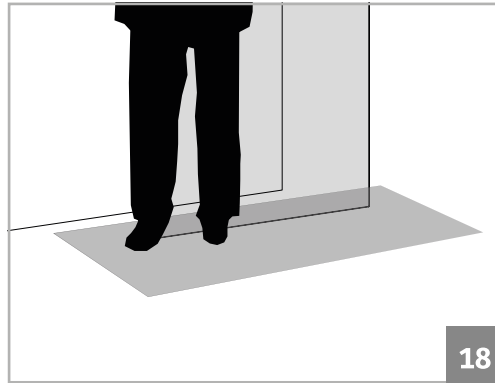

18

18. Use a card or other protective material under the door so as not to damage the equipment.

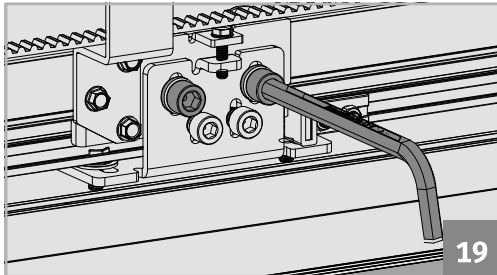

19

19. Slightly loosen the screws shown in the image.

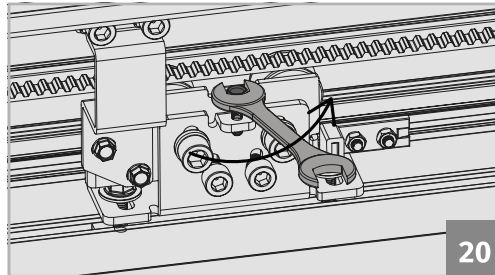

20

20. Now turn the screw Y, so that the cart descends towards the door.

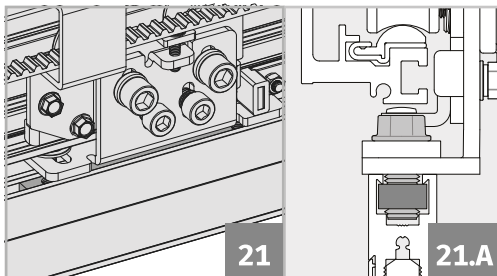

21

21 and 22. Point the plates within the gripper to the cart screws and tighten them. Repeat the steps, starting from step 17, for the second glass if necessary.

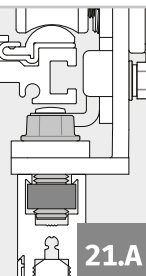

21.A

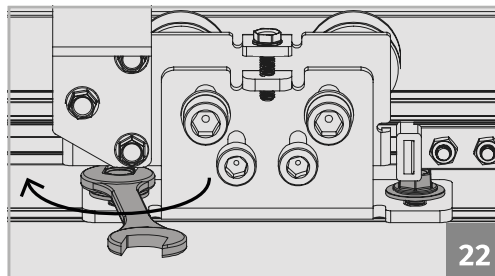

22

04. INSTALLATION

GLASS INSTALLATION IN SAFE

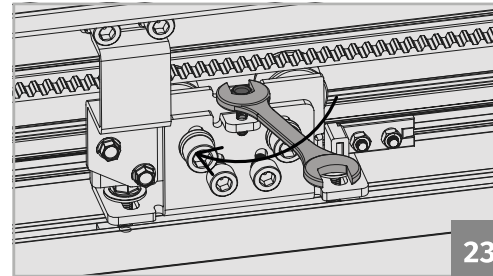

23

23. Use once again the screw Y to the cart rises along with the door. The glass should be between 8 and 10 mm from the ground.

• DOORS ADJUSTMENT

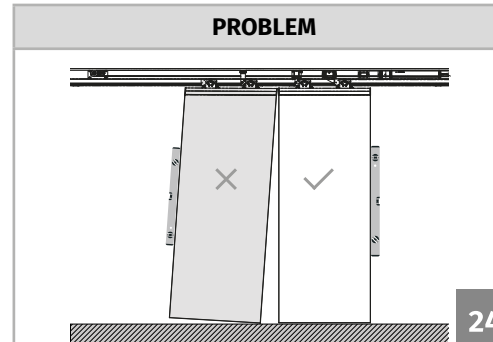

24

The door is not parallel to the ground.

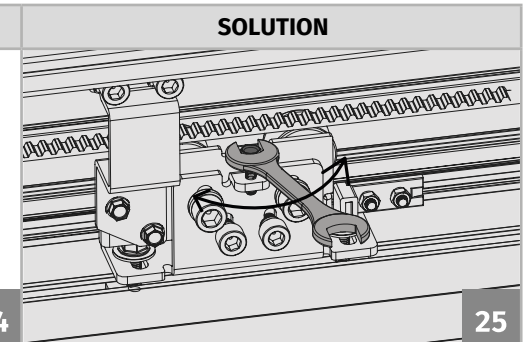

25

Use the screw shown in the image to bring up/down the door on the side you find more appropriate.

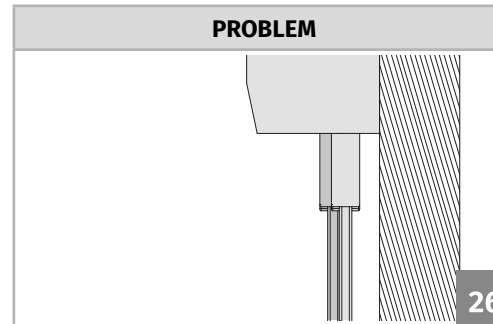

26

The door is not aligned laterally with the second door.

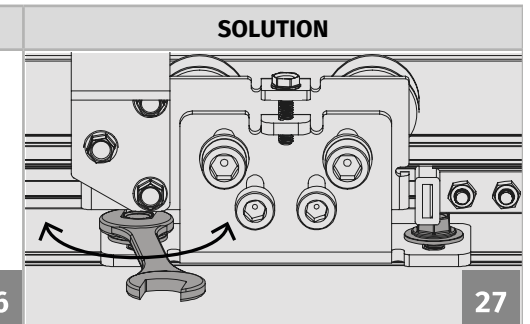

27

Slightly relieve the 4 screws that hold the door so that you can slide it to the position that you think it is the most correct. Retighten the screws after adjustment.

04. INSTALLATION

GUIDES INSTALLATION

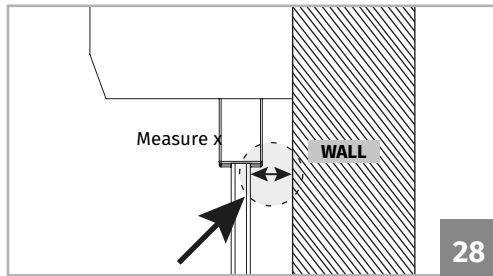

28

28. Take the measurement between the glass and the upper part of the glass (under the gripper).

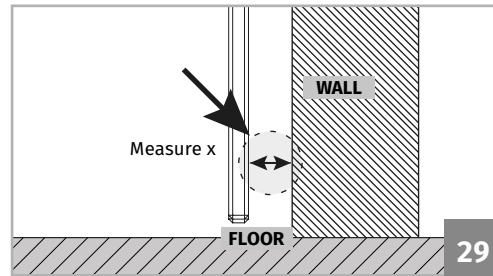

29

29. Take the same measurement to the glass's lower limit.

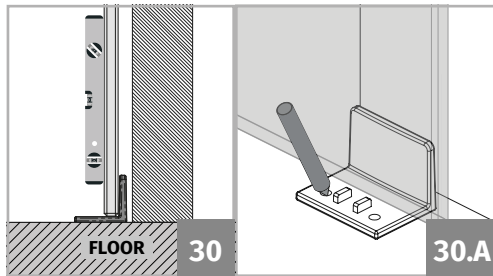

FLOOR 30

30.A

30. Now place the guide (without frontal cover) on the glass and align it by the wall limit.

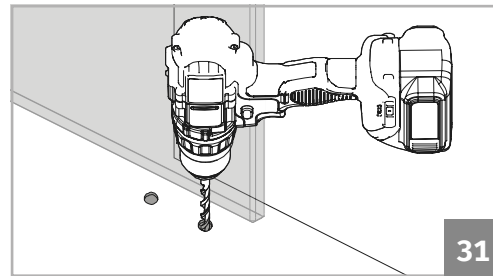

31

31. Do the markings, remove the guide and drill it with an appropriate size for the purpose.

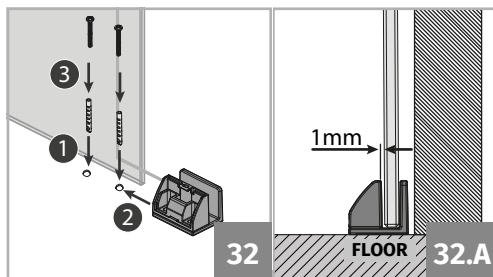

32

1mm

FLOOR 32.A

32. Put the plastic plugs, put the guide and fasten with suitable screws, leaving a gap of 1mm between the glass and the guide (32.A). You can also adjust this space in 5mm.

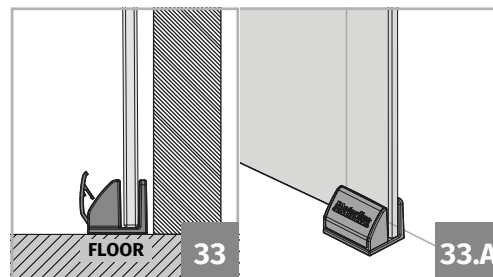

FLOOR 33

33.A

33. Refit the cap and repeat this procedure for the other side.

04. INSTALLATION

STOPPERS ADJUSTMENT

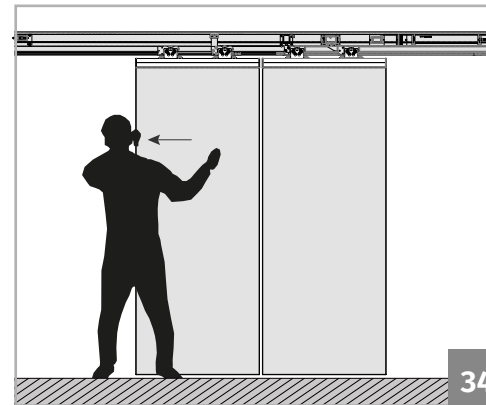

34

34 and 35. Make a complete manual opening to check for obstacles during opening / closing and if the course is fully made. If it doesn't, adjust the stoppers position inside the safe. Unscrew slightly the two screws (30) and move the stopper to the desired location.

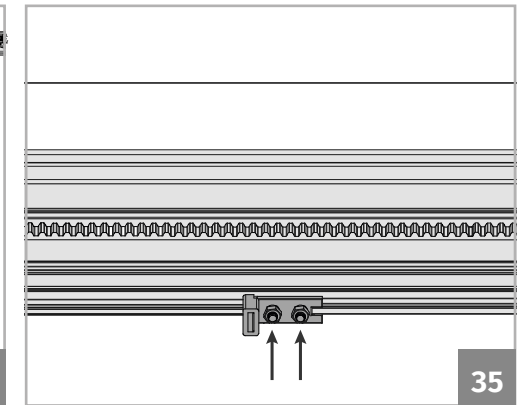

35

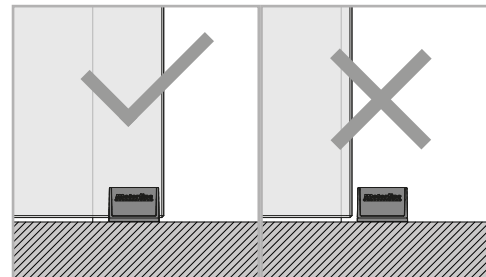

ATTENTION: Make sure that the door never leaves the guide in fully open and closed position. To do so, the glass must overlap between 30 to 40mm (min).

• STOPPERS LOCATION

One leaf door - 2 stoppers

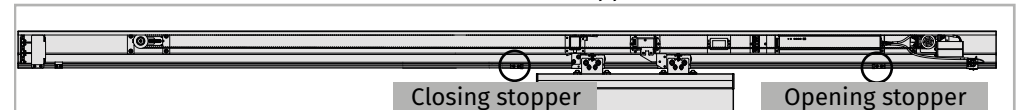

Two leaves door - 2 stoppers

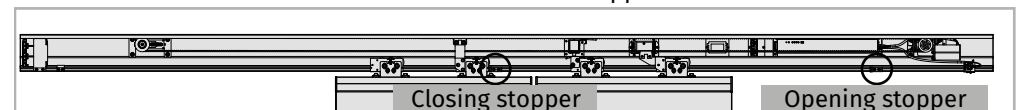

04. INSTALLATION

COMPONENTS

After installing the motors and glasses, proceed to the installation of all the extra components that are in the order. These may include:



M CELE 01
Selector

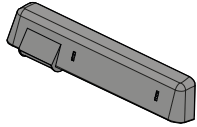

MR27
Radar

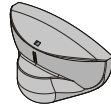

M1601
Radar



FOTO9S1A
Photocells

To install these components, by following the instructions in each manual. You can find it inside the packaging or attached to this manual.

230V/110V CONNECTION

After installing and connecting all components, you must connect the automation to a power supply.

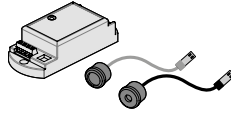

In 230v version, the fuse wires goes directly to the control board, while in 110V version goes to transformer.

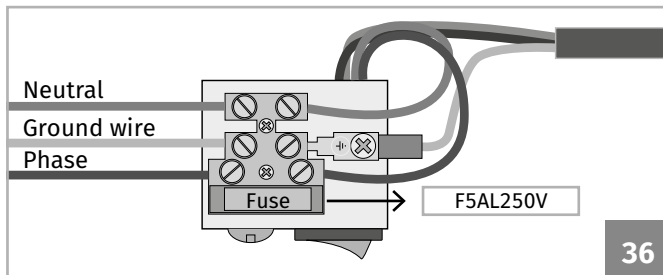
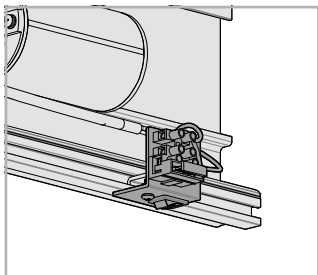

36. Make the wiring as shown in the image.



Before connecting the wires, make sure that the power button is turned off!

Turn ON now the door by clicking the red button.

Once that button is triggered, the door will make a full slowly opening and closing maneuver, recognizing and automatically saving the route.

Test the installed components, interrupting the their signal and observing the behavior of the door.

Finally, connect the batteries (instructions on the next page - BATTERIES ACTIVATION).

04. INSTALLATION

BATTERIES

The automatic glass door has 3 batteries of 12V each, connected in series (36V connection). These batteries are an important safety element to make the opening in case of power failure.

• BATTERIES ACTIVATION

ATTENTION: The K2 dipper must be enabled! (More info in page 17A)

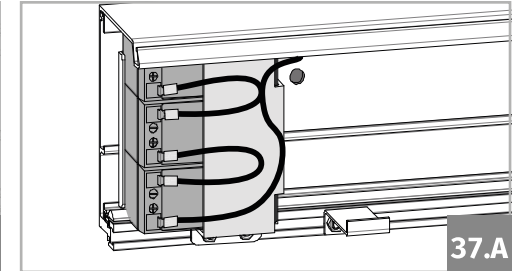
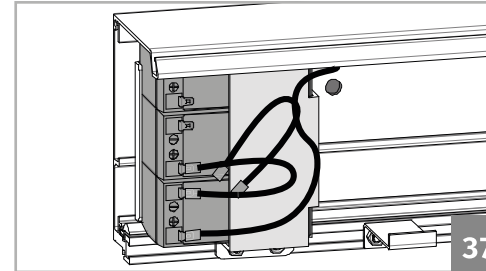

37. After testing all the components, connect the batteries by placing the loosen cable.

• REPLACING BATTERIES

If you need to replace any battery, follow the next steps:

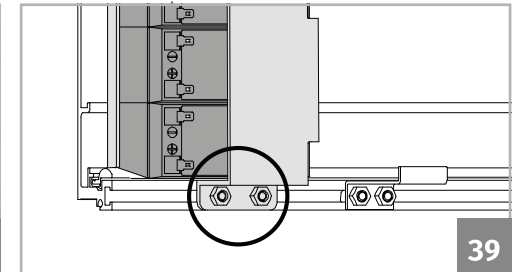
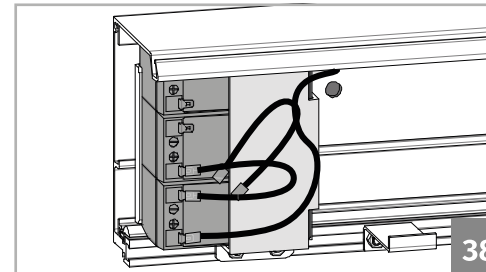

38. Disconnect the cables that connect the batteries.

39. With a wrench, unscrew the two screws shown in the image above. Grab the metal plate throughout the process, to prevent the batteries from falling once you unscrew them completely.

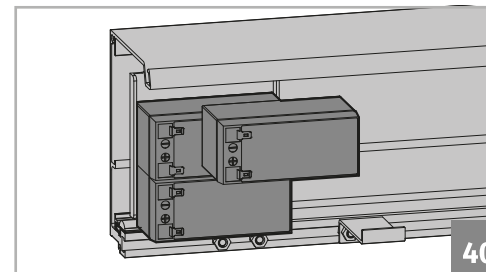

40. Change the batteries, replace the metal plate and tighten the two screws.

05. PROGRAMMING

CONTROL BOARD

• PRE-PROGRAMMING CAUTIONS

The parameters selected in the control device are available after the door makes a fully open and close maneuver (path recognition).

Have the full sense of the weight and the measurements of the door you want to program because the sensitivity must be adjusted according with them.

When adjusting the sensitivity, it is also necessary to adjust the speed in order to prevent the door to detect obstacles and thus presents a continuous movement.

• DESCRIPTION

Their characteristics are as follows:

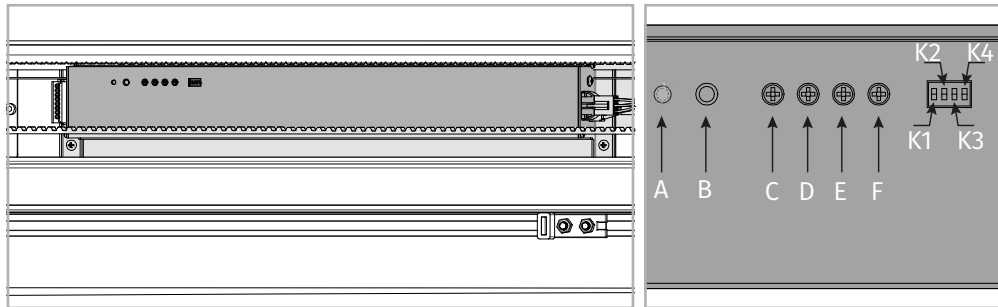

LEGENDA DOS DIPPERS DA CENTRAL

K1	ON	Activates the output of power to the motor, allowing the selected operation of k4.
	OFF	Disables the output of power to the motor, defined on k4.
K2	ON	In case of power failure, the door remains closed.
	OFF	In case of power failure, emergency batteries keep the door open. The door will open continuously until the power does not return. It works on all selector functions except for doors with the selector with "LOCK" the function ON, with an electric lock installed.
K3	ON	Opening a leaf to the left.
	OFF	Double opening or opening one leaf to the right.
K4	ON	More strength in the closing maneuver to the mechanical anti-panic system mode.
	OFF	Standard 2V output to keep the door closed.

05. PROGRAMMING

CONTROL BOARD

CONTROL BOARD DESCRIPTION

A	Indication LED	It indicates the control board's power supply.
B	Start button	After pressing this button, the door will open.
C	Adjust door opening speed	When rotating from the right to the left, it will decrease the door's opening speed. If your turn from the left to the right, it will increase. The speed can be adjusted from 300 to 550 mm/s.
D	Adjust door closing speed	When rotating from the right to the left, it will decrease the door's closing speed. If your turn from the left to the right, it will increase. The speed can be adjusted from 300 to 550 mm/s.
E	Pause time adjustment	If you turn from right to left, it will decrease the time the door waits from the point it opens up to a new recognition before closing. If you turn from left to right, it will increase. It can be adjusted between 0 and 20 sec.
F	Reverse sensitivity adjustment	If you rotate from right to left, it will increase the sensitivity of the door. If you rotate from left to right, it will decrease. If you decrease the sensitivity excessively, it may cause accidents or failures in the motor.

• CONTROL BOARD CONNECTORS DESCRIPTION

LATERAL A

FRONTAL VIEW

LATERAL B



05. PROGRAMMING

CONTROL BOARD

• LATERAL A

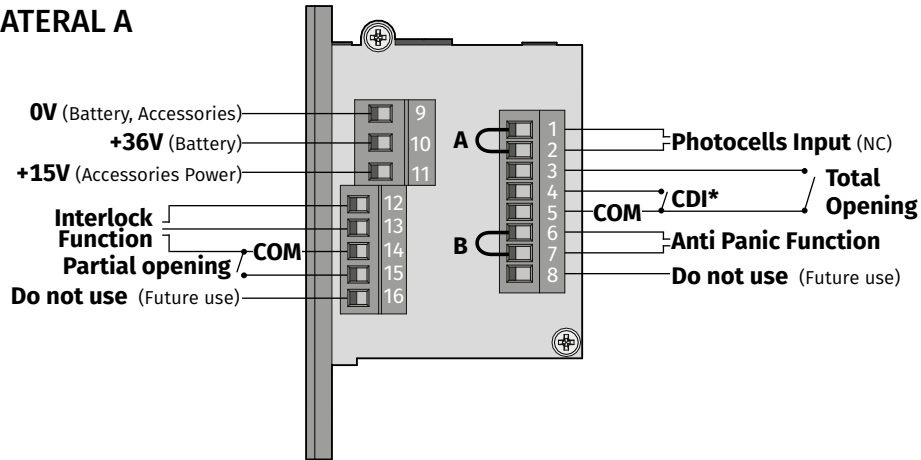

CDI* - Fire Alarm

Use the connectors 4 and 5 so the fire alarm send an impulse to the door open permanently. Always install a electric lock on the door so that, in case of a impulse given im a moment that the door should not open (eg. store at night) this will keep the door closed.

SHUNTS

- A** The outputs 1 and 2 is for photocells connection. If you do not use this function (photocells + module and / or radar MR27) place a shunt between the two outputs.
- B** The outputs 6 and 7 are only for antipanic glass doors. If you do not use this feature, place a shunt between the two outputs.

• LATERAL B

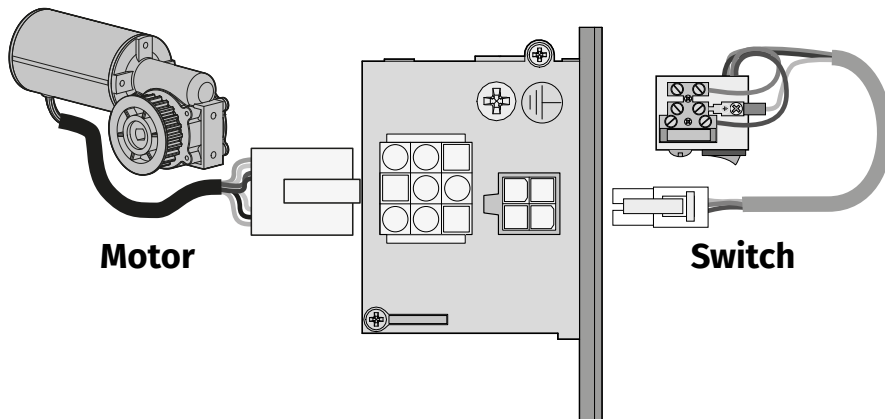

05. PROGRAMMING

CONTROL BOARD - INTERLOCK FUNCTION

The control board allows the interconnection of two automatic glass doors through the interlock function (door with interlocking). With this feature, when a door opens, the other remains closed until the first is completely closed. Thus, the two doors will never be open at the same time. This function can be used to eliminate air drafts in spaces like shops or restaurants.

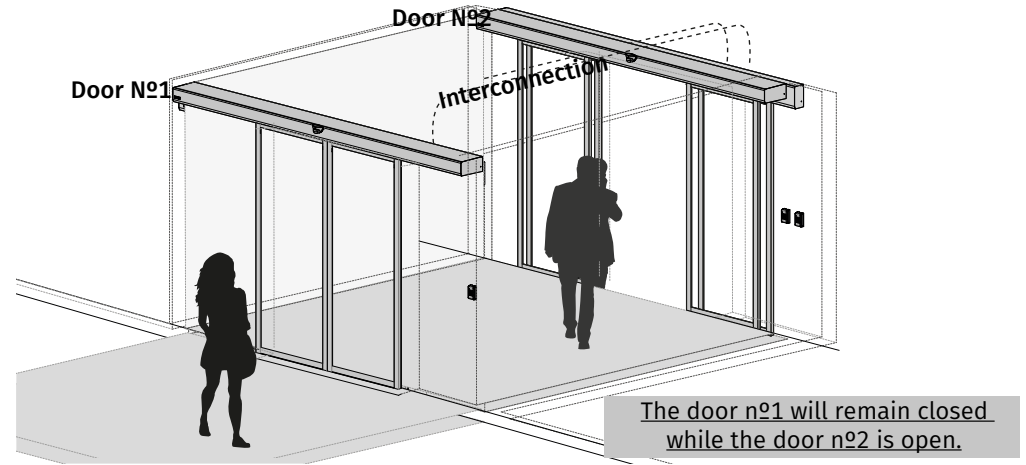

• CONNECTIONS BETWEEN CONTROL BOARD

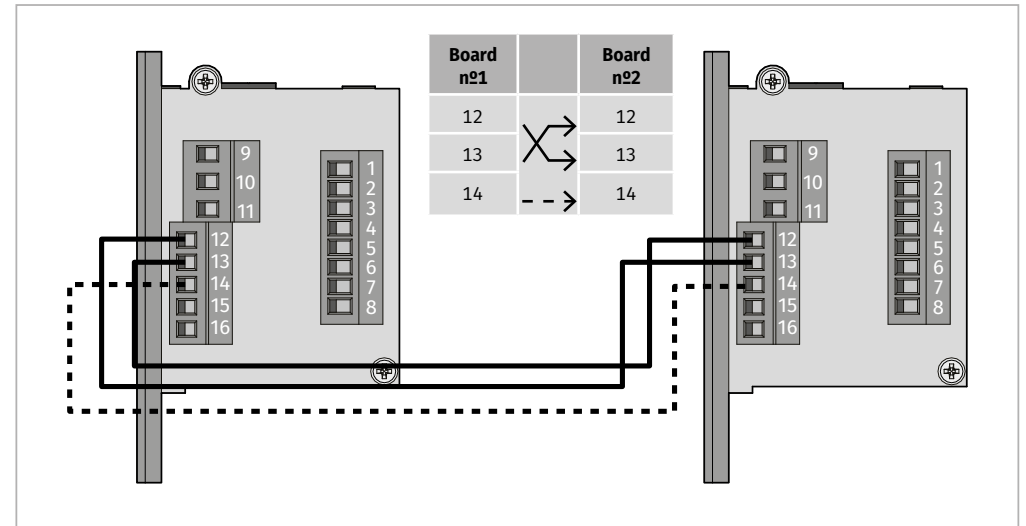

05. PROGRAMMING

SELETOR

Com os comandos do seletor, pode controlar o automatismo para realizar as seguintes ações:

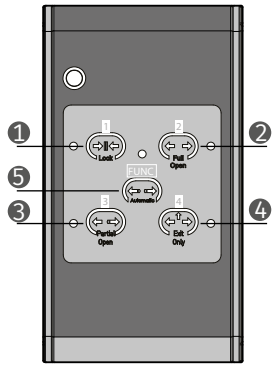

1. Always Closed:

All radars and controllers are disabled. The lock is automatically triggered, which causes the door to close. If you connect a fire alarm and put the door in this function, the door will not open if it receives an alarm order.

2. Always Open:

All radars and controllers are disabled. The door stays open.

3. Partial Opening (Automatic Operation):

The radars are activated. The door opens only partially (65% of total course) automatically. Whenever activated this function, the door does a new path recognition.

4. Exit Only:

The external radar is disabled and the lock is activated automatically. The controllers and inner radar stay activated. Only opens for exiting people.

5. Total Opening (Automatic Operation):

All radars and controllers are activated. The door opens and closes automatically.

• PROGRAMMING

You can use the selector in two modes: Code and Free. In "code" it is necessary to put a combination of four numbers (original code is 1234) to change the operating function.

Changing from "Code Mode" to "Free Mode":

Press and hold the FUNC button + 1 key (LOCK) for 5 sec. The selector will beep and the light changes from red (Code mode) to green, indicating that it is in free mode. Repeat the procedure to switch to code mode.

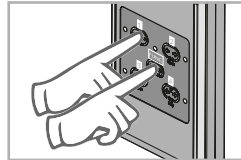

Change the selector's function in "Code Mode":

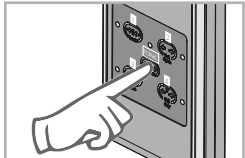

01 • Press and hold the FUNC button for 5 sec. The selector will beep and the LED turns green.

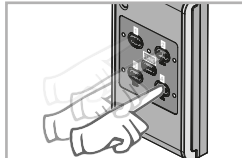

02 • Enter the code (original - 1234).

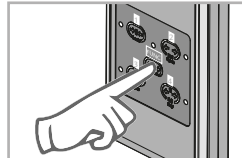

03 • Press the FUNC button to confirm.

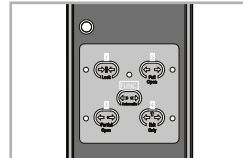

04 • Choose one of the functions described above by pressing the key corresponding to the function.

05. PROGRAMMING

SELETOR

Change the selector's function in "Free Mode":

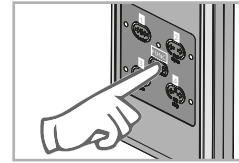

In "free" mode, you can select the desired function by pressing it for 5sec, without having to put the password.

Change Password:

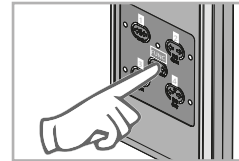

01 • Press and hold the FUNC button for 10 sec. The selector will beep twice. First at 5 sec and then at 10 sec.

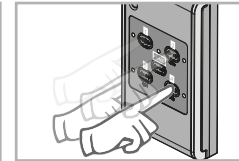

02 • Enter the code (original - 1234).

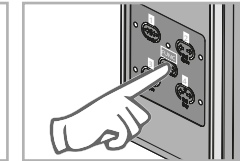

03 • Press the FUNC button to confirm.

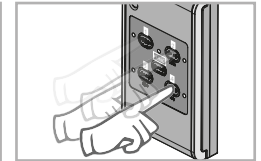

04 • Enter a new code.

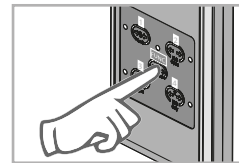

05 • Press the FUNC button to confirm.

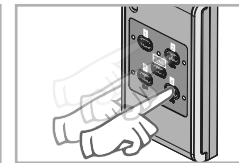

06 • Enter for a second time the new code.

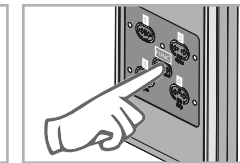

07 • Press the FUNC button to confirm again. The new password is now set.

Reset the Selector:

In case of forgetting your password, follow the next steps:

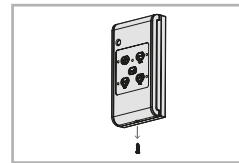

01 • Unscrew the screw cover (below the switch) and remove the rear panel.

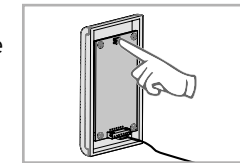

02 • Unscrew the screw cover (below the switch) and remove the rear panel.

03 • The selector beeps once confirming the reset's success. The password returns to 1234. Refit the back cover and tighten the screw.

06. MAINTENANCE

BELT

• BELT TENSION ADJUSTMENT

A long period of door maneuvers can lead to an alteration on the belt tension. For this reason it is recommended a belt tension periodic review to ensure the normal operation of the door.

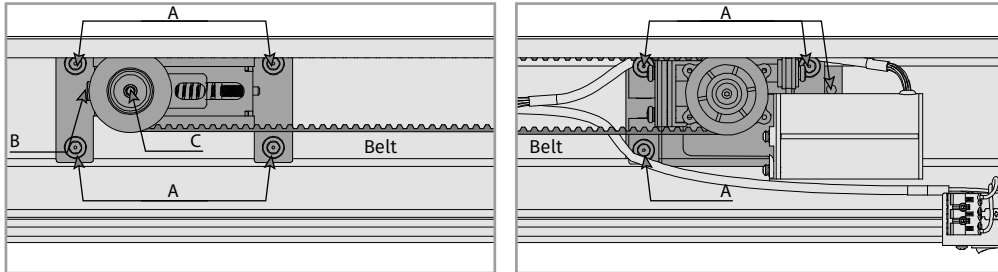

Attention: First, check the tightening of the screws (A). These screws keep the turnbuckles of the belt fixed. If these screws lose strength, the belt may lose tension.

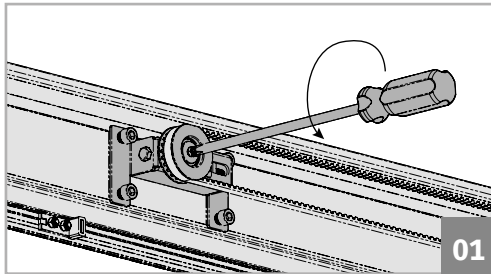

01. To start the belt tension adjustment, loosen first, the screw (C). When this screw is tightened, it locks the bolt (B), preventing it of losing strength.

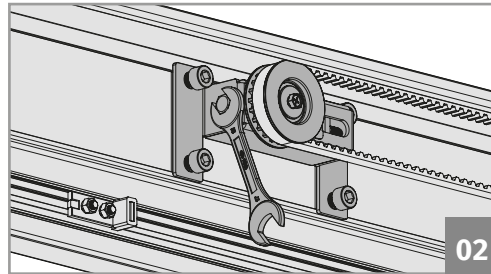

02. Turn the screw (B) to increase or decrease the belt tension. To find out if the voltage is properly adjusted, press the belt at middle position, the top against the bottom. These should not be able to touch each other.

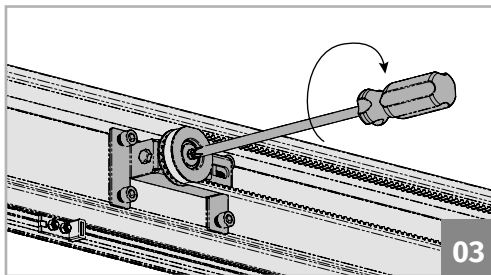

03. Tighten the screw (C) to finish the setting.

06. MAINTENANCE

OTHER INFORMATION

• VERIFICATIONS

It is recommended a full periodic check to ensure the normal operation of the door. This review can only be performed by qualified technicians in handling automatic glass doors.

Check the following points during the review:

General	Leveling of the automation; Automation grip to the surface; Cable wrapping; Review label;
Leaves	Noise from the carts; Gap in anti-derailment system; Alignment of the leaves; Gap inside the guides; Carts and rail cleanness; Stoppers adjustment;
Belt	Belt tension; Belt wear;
Motor	Noise in the motor; Motor's connection cables;
Control board	Cleaning insects; Power protected by circuit breaker and ground wire; Door's speed / strength; Motor's connection cables;
Components	Selector's functioning; Radar's response and range; Photocells functioning; Photocells alignment; Electric lock and unlocking crank functioning;



Before performing any operation on the door is required to turn off the electric current.

• ELIMINATION

At the end of its working lifetime, all components must be removed from the place by a qualified installer who must take into account all precautions and safety measures during the procedure.

Never place the components in domestic waste or uncontrolled landfills because they would contaminate the environment. These must be deposited into appropriate recycling containers, to be separated according to their materials.

07. TROUBLESHOOTING

MALFUNCTION DIAGNOSIS

Problems	Causes	Solutions
The door does not move.	1. Power failure.	Make sure the door is receiving power supply.
	2. Door stuck.	Separate the door from the belt and check if the leaves move by hand without any problem.
	3. Blown fuse.	Check the M1201 fuse state on the switch (page 16A) and replace it if necessary.
	4. Disconnected cables.	Make sure that all the cables are well connected.
The door opens and closes with a low speed.	1. Leaves with friction on the guides.	Make sure that the leaves have the necessary clearance on the guides or if they are squeezing the glass (1mm).
	2. Carts with damaged bearings.	Separate the belt from the door and move the it manually. Replace the carts if these are damaged.
	3. Belt tensioner with damaged bearing.	Remove the belt tensioner and turn the wheel manually. If there is noise or unusual friction, replace the component.
	4. Defective control board.	Change the position of the potentiometers C and D (page 16A) and check if the control board changes the behavior during the opening and closing maneuvers. If it does not happen, the control board has anomalies.
	5. Motor with gearbox stucked.	Without belt and power, check if the motor rotates manually.
The door does not close.	1. Radar sends continuous signal.	Turn off one radar at a time and check if the door closes.
	2. Photocells always open.	Make sure that the cables which connect the photocells module to the control board, close the NC circuit. Place a shunt on input 1 and 2 and check if the door closes. If it closes, check the cells power.
The door reverses when closing.	1. There are obstacles in the sensor detection area.	Remove the obstacles in the sensor's detection area.
	2. The door leaves are within the detection area.	Adjust the detection area and the sensitivity of the sensor (see sensor manual).
	3. Photocells misaligned.	Align the photocells.
	4. Friction between some components of the door.	Analyze, by moving the leaves manually, where there is contact between components.
The leaves hit violently with each other.	1. Problem in the stoppers.	Make sure that the stoppers are tight and in place.
	2. Malfunction in control board.	Change the position of the potentiometers C and D (page 17B) and check if the control board changes the behavior during the opening and closing maneuvers. Do a reset to the control board by switching off the batteries and the power supply for 5 seconds. Power up again in order to the door initiate a new programming.