

MotionProtect Curtain User Manual

Updated September 8, 2022



MotionProtect Curtain is a curtain type wireless motion detector. The detector has a narrow horizontal detection angle and is designed for indoor perimeter control: windows, doorways, and other entrances or exits of the guarded facility. Maximum motion detection distance is 15 m.

MotionProtect Curtain integrates into Ajax security systems, connecting to a hub through the Jeweller secure protocol. Wireless coverage may reach up to 1,700 m line-of-sight. The pre-installed battery ensures up to 3 years of autonomous operation.

An iOS or Android app is used for detector setup. It also notifies the user about any events with push notifications, SMS, or calls (if enabled).

Ajax can be connected to the central monitoring station of a security company.



Connection to [ocBridge Plus](#) and [uartBridge](#) integration modules is not provided.

Buy curtain type motion detector MotionProtect Curtain

Functional Elements

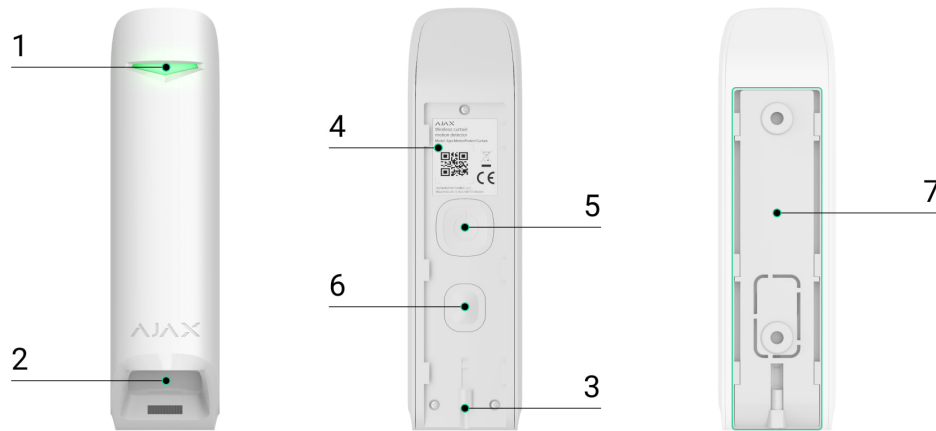

1. LED indicator.
2. Motion detector lens.
3. Hole for fixing the SmartBracket mounting panel with the bundled screw.
4. QR code with the device ID. Used to connect to the Ajax security system.
5. Button to turn on/off the device.
6. Tamper button. Triggers when trying to tear off the detector from the surface or remove it from the mount.
7. SmartBracket mounting plate. To remove the plate, slide it down.

Operating Principle

00:00

00:12

Once the system is armed, the detector starts polling its two IR sensors. If a motion is detected, an alarm state is instantly sent to the hub and green LED starts flashing on the device. Having caught an alarm state, the Hub triggers sirens and notifies the user and the security company.



Motion alarms are sent every 5 seconds

To prevent false alarms, MotionProtect Curtain has a Correlation Signal Processing functionality that can be enabled in the detector's settings. Once it is active, the detector starts sending alarm states to the hub only if an identical motion signal is registered by both IR sensors. If it is disabled, MotionProtect Curtain sends an alarm state even with one of the two IR sensors triggered.

What is correlation signal analysis and how does it work

Pairing the Detector with a hub

Before you start pairing the detector:

1. Turn on your hub and check the Internet connection (via Ethernet and/or GSM).
2. Install the Ajax application on your smartphone. Create an account, add your hub to the app, and create at least one room.

3. Check the status of the hub in the app to make sure it is disarmed and is not updating.



Please note that only a user with admin permissions can add devices to the hub

Pairing MotionProtect Curtain with a hub:

1. In the Ajax mobile app, tap **Add device**.
2. Name the device, scan the **QR code** or enter it manually (placed on the back of the detector body or its packaging), select the room for placement, and tap **Add**. The countdown will start.



3. Turn on the detector by holding its power button for 3 seconds.



For detection and pairing to occur, the device must be within a hub's wireless coverage (at the same facility). The connection request will be sent to the Hub only once the device turns on.

If the MotionProtect Curtain fails to connect to the hub, it will automatically power down within 6 seconds after turning on. There is no need to turn off the device to retry.

If the MotionProtect Curtain has already been paired with another hub, turn off the detector, and then follow the standard pairing procedure.

After pairing, the detector will appear on the app's hub device list. The frequency of the device status updates depends on the polling interval indicated in the hub's settings (36 seconds by default).

If the detector identifies movement before the system is armed, it will activate not immediately but the next it is polled by the hub.

States

The states display information about the device and its operating parameters. MotionProtect Curtain states are available in the Ajax apps. To view them:

1. Sign in to the Ajax app.
2. Select the hub if you have several of them or using a PRO app.
3. Go to the **Devices**  menu.
4. Select MotionProtect Curtain from the list.

Parameter	Value
Temperature	<p>Detector temperature. It is measured on the processor of the detector and changes gradually.</p> <p>The acceptable error between the value in the app and the ambient temperature is 2°C.</p> <p>The value is updated as soon as the detector identifies a temperature change of at least 1°C.</p>

Jeweller Signal Strength	<p>Signal strength between the detector and the hub or the range extender via the Jeweller channel. The recommended value is 2–3 bars.</p> <p>Jeweller is a protocol for transmitting MotionProtect Curtain events and alarms.</p>
Connection via Jeweller	<p>Connection status on the Jeweller channel between the detector and the hub or the range extender:</p> <ul style="list-style-type: none"> • Online – the detector is connected to the hub or the range extender. • Offline – the detector is not connected to the hub or the range extender. Check the detector connection.
ReX	<p>Displays the status of using a <u>radio signal range extender</u></p>
Battery Charge	<p>The battery charge level of the device:</p> <ul style="list-style-type: none"> • OK • Battery discharged <p>The Ajax apps and the security company will receive appropriate notifications when the batteries are low.</p> <p>After sending a low battery notification, the detector can work for up to 2 months.</p> <p><u>How the battery charge is displayed</u></p> <p><u>Battery life calculator</u></p>
Lid	<p>The status of the detector’s tamper that responds to detachment of the device from the surface or opening of the body:</p> <ul style="list-style-type: none"> • Open – the detector was removed from the SmartBracket panel, or the integrity of its

	<p>body was compromised. Check the mounting of the detector.</p> <ul style="list-style-type: none"> • Closed – the detector is installed on the SmartBracket mounting panel. The body’s integrity and the mounting panel wasn’t compromised—normal state. <p>Learn more</p>
<p>Delay When Entering, sec</p>	<p>Delay time when entering: from 5 to 120 seconds.</p> <p>Delay when entering (alarm activation delay) is the time the user has to disarm the security system after entering the secured area.</p> <p>Learn more</p>
<p>Delay When Leaving, sec</p>	<p>Delay time when leaving: from 5 to 120 seconds.</p> <p>Delay when leaving (arming delay) is the time the user has to leave the secured area after the security system arms.</p> <p>Learn more</p>
<p>Sensitivity</p>	<p>The sensitivity level of the motion detector:</p> <ul style="list-style-type: none"> • Low • Normal • High <p>The sensitivity is selected based on the results of the detection zone test.</p>
<p>Correlation signal processing</p>	<p>Status of the signal correlation processing functionality</p>
<p>Always Active</p>	<p>When this option is enabled, the detector is always armed.</p> <p>This means that the detector will constantly respond to motion and raise alarms regardless of</p>

	the system arming mode.
	<p>Learn more</p>
Temporary Deactivation	<p>Shows the status of the device temporary deactivation function:</p> <ul style="list-style-type: none"> • No – the device operates normally and transmits all events. • Lid only – the hub administrator has disabled notifications about triggering on the device body. • Entirely – the device is completely excluded from the system operation by the hub administrator. The device does not follow system commands and does not report alarms or other events. • By number of alarms – the device is automatically disabled when the number of alarms is exceeded (specified in the settings for Devices Auto Deactivation). The feature is configured in the Ajax PRO app. <p>Learn more</p>
Firmware	The detector's firmware version.
Device ID	Device identifier. It is also available on the QR code on the detector enclosure and its package box.
Device No.	The number of the device loop (zone).

Detector Setup

To change the detector settings in the Ajax app:

1. Select the hub if you have several of them or using a PRO app.
2. Go to the **Devices**  tab.
3. Select MotionProtect Curtain from the list.

4. Go to **Settings** by clicking on the gear icon .

5. Set the required parameters.

6. Click **Back** to save the new settings.

Setting	Value
Name	<p>Detector name. It is displayed in the list of hub devices, SMS text, and notifications in the event feed.</p> <p>To change the detector name, click on the text field next to the name.</p> <p>The name can contain up to 12 Cyrillic characters or up to 24 Latin characters.</p>
Room	<p>Select the virtual room to which the MotionProtect Curtain is assigned.</p> <p>The room name is displayed in the text of SMS and notifications in the events feed of the Ajax apps.</p>
Sensitivity	<p>The motion detector sensitivity level. The choice depends on the type of the object, the presence of probable sources of false alarms, and the specifics of the protected area:</p> <ul style="list-style-type: none">• Low – there are likely sources of false alarms in the protected area. For example, tall bushes.• Normal (default value) – recommended value, suitable for most objects. Do not change it if the detector works correctly.• High – there is no interference in the protected area; the maximum range of detection and the alarm detection speed are important. For example, if the detector is installed in a narrow passage. <p>Before selecting the sensitivity level, conduct the <u>detection zone test</u>. If during the test, the</p>

	<p>detector doesn't react to movement in 5 cases out of 5, the sensitivity should be increased.</p>
Correlation signal processing	<p>When this option is enabled and motion is detected, MotionProtect Curtain additionally analyzes the received signals from two infrared sensors to protect against false alarms.</p> <p>Learn more</p>
Always Active	<p>When this option is enabled, the detector is permanently in armed mode.</p> <p>This means that the detector will constantly respond to motion and raise alarms regardless of the system arming mode.</p> <p>Learn more</p>
Delay When Entering, sec	<p>Delay time when entering: from 5 to 120 seconds.</p> <p>Delay when entering (alarm activation delay) is the time the user has to disarm the security system after entering the secured area.</p> <p>Learn more</p>
Delay When Leaving, sec	<p>Delay time when leaving: from 5 to 120 seconds.</p> <p>Delay when leaving (arming delay) is the time the user has to leave the secured area after the security system arms.</p> <p>Learn more</p>
Arm in Night Mode	<p>If active, the detector becomes armed once system enters Night Mode</p>
Night Mode Delay When Entering, sec	<p>Delay time when entering in Night Mode: 5 to 120 seconds.</p> <p>Delay when entering (alarm activation delay) is the time the user has to disarm the security system after entering the premises.</p>

	<p><u>Learn more</u></p>
Night Mode Delay When Leaving, sec	<p>Delay time when leaving in Night Mode: 5 to 120 seconds.</p> <p>Delay when leaving (arming delay) is the time the user has to leave the premises after arming.</p> <p><u>Learn more</u></p>
Alarm LED indication	<p>Allows you to disable the flashing of the LED indicator during an alarm. Available for devices with firmware version 6.53.1.1 or higher</p> <p><u>How to find the firmware version or the ID of the detector or device</u></p>
Alert with a siren if motion detected	<p>If active, <u>sirens</u> added to the system are activated if the motion is detected</p>
Jeweller Signal Strength Test	<p>Switches the detector to the Jeweller signal strength test mode.</p> <p>The test allows you to check the signal strength between the detector and the hub or the range extender over the Jeweller wireless data transfer protocol to determine the optimal installation location for the device.</p> <p>The recommended value is 2–3 bars.</p> <p><u>Learn more</u></p>
Detection Zone Test	<p>Switches the detector to the detection zone test mode.</p> <p>The test enables users to check how the detector responds to movement and to determine the optimal installation location.</p> <p>If, during the test, the detector does not respond to motion in 5 cases out of 5, increase the sensitivity or change the detector's location.</p>

	<p>Learn more</p>
Signal Attenuation Test	<p>Switches the detector to the signal attenuation test mode.</p> <p>During the test, the transmitter power is decreased or increased to simulate a change in the environment to test the communication stability between the detector and the hub.</p> <p>Available in detectors with firmware version 3.50 or later.</p> <p>Learn more</p>
Temporary Deactivation	<p>Allows the user to disable the device without removing it from the system.</p> <p>Three options are available:</p> <ul style="list-style-type: none"> • No. • Entirely – the device does not execute system commands and does not participate in automation scenarios, and the system ignores alarms and other device notifications. • Lid only – the system ignores the detector tamper triggering notifications. <p>More about temporary deactivation</p> <p>The system can also automatically deactivate devices when the preset number of alarms is exceeded.</p> <p>More about auto deactivation</p>
User Guide	<p>Opens the MotionProtect Curtain User Guide in the Ajax app.</p>
Unpair Device	<p>It unpairs the detector: disconnects it from the hub, and deletes its settings.</p>

Detector Indication

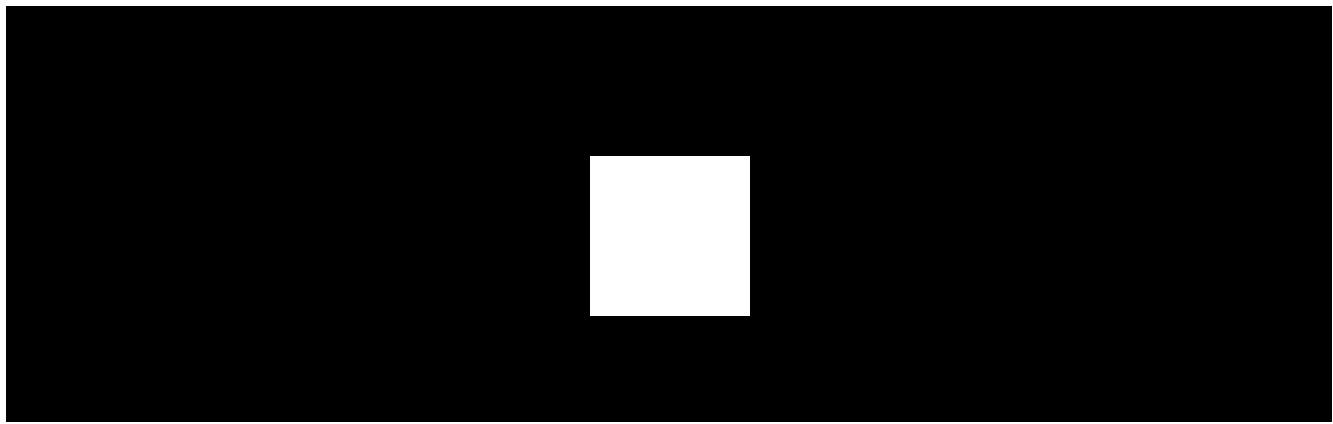

00:00

00:03

The MotionProtect Curtain indicator LED may turn red or green, depending on the status of the device.

Indication when pressing the power button

Event	Indication
The power button is pressed (detector is on)	Lights up red while the button is held
Turning on	Lights up green while the device is turning on
Turning off	Lights up red, then flashes three times

Active detector indication

Event	Indication	Note
Connecting the detector to the hub	Lights up green for a few seconds	
Hardware error	Flashes red continuously	The detector needs to be repaired, contact support
Motion or tamper alarm triggered	Lights up green for about 1 second	
Battery replacement needed	Smoothly lights up green and goes off	For battery replacement procedure, see Battery replacement manual

Integrity Testing

Ajax security systems can run tests to verify the integrity of connected devices.

The tests start instantly, but no later than within 36 seconds by default. The test start time depends on the detector polling interval setting (see the **Jeweller** section in the Hub settings).

Jeweller Signal Strength Test

Detection Zone Test

Signal Attenuation Test

Detector Placement



The effectiveness of the security system depends on detector placement. Choosing a location to install MotionProtect Curtain, consider the direction of the light filter and obstacles that may affect the detector's field of view and the radio signal transmission.

Consider the detection range as well as the beam width when installing the detector. Incorrect device placement can lead to false alarms or improper operation of the device.

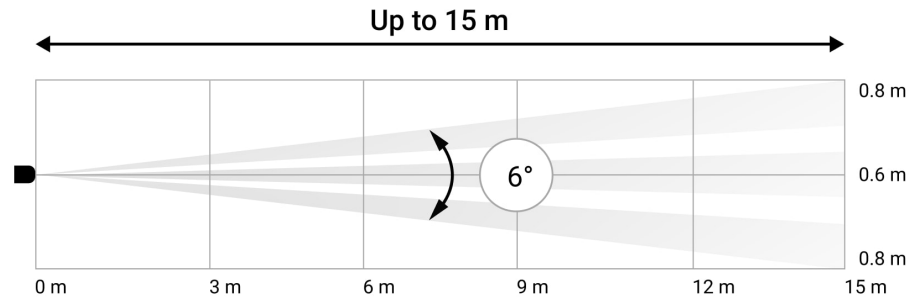
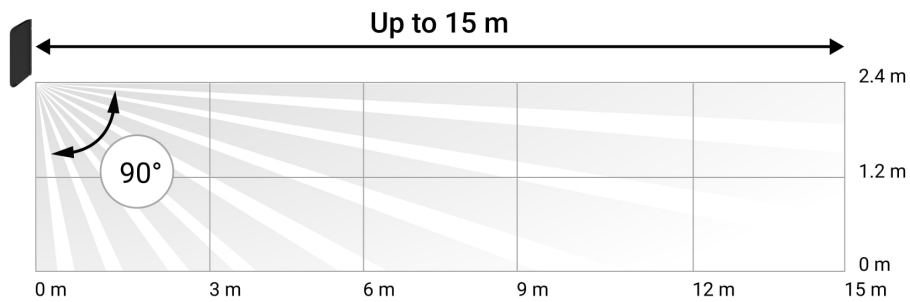

Horizontal and vertical detector's angles of view

Detection range	Beam width
3 meters	0.3 meters
6 meters	0.6 meters
9 meters	0.9 meters
12 meters	1.25 meters
15 meters	1.55 meters



The device developed only for indoor use.

Do not install the detector:

- Outside the premises (outdoors)
- In front of the windows within reach of direct sunlight
- Opposite of the objects that rapidly change temperature (e.g., electric and gas heaters)

- Opposite of the moving objects having a temperature close to that of the human body (curtains swaying above a heating radiator)
- In places with fast air circulation (near fans, open windows or doors)
- Near metal objects and mirrors that cause the attenuation or interfere with radio signals
- Within any premises with the temperature and humidity beyond the permitted range
- Closer than 1 m to a hub

If the detector keeps reacting to interference and raising false alarms, but it is impossible to install it anywhere else, the Correlation Signal Processing can be enabled in the settings.



Please note that if the **Correlation Signal Processing** is enabled, the range of motion detection is reduced depending on the detector sensitivity chosen

Sensitivity	Motion detection range w/ Signal Correlation Processing *	Motion detection range w/o Signal Correlation Processing *
Low	Up to 6 m	Up to 11 m
Normal	Up to 7 m	Up to 13 m
High	Up to 8 m	Up to 15 m

*at an ambient temperature of 23°C

If possible, avoid situations where the detector identifies movement at a longer distance than required. The best place to install it is within an enclosed place. For instance, to detect movement in an archway, install the detector in it. This way, the detector will be triggered only by a person that enters it.



To prevent the detector from reacting to domestic animals, install it upside down, leaving space for the free movement of animals below the detection zone.

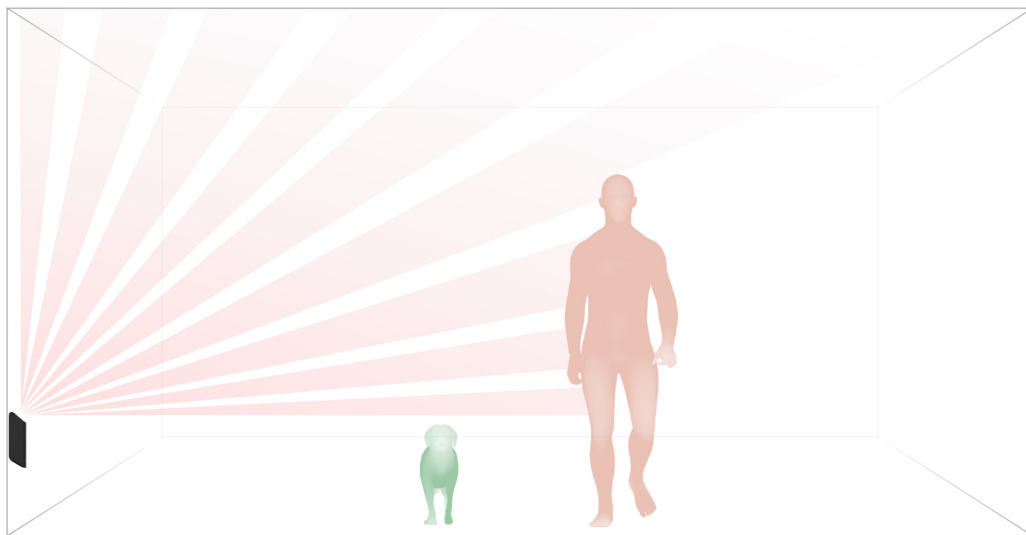

The placement of a MotionProtect Curtain also depends on the distance to a hub and whether there are any obstacles between the devices that may hinder the radio signal, e.g., walls, floor deck, or large objects in the room.

Check the signal strength at the placement location. If you have a signal level of one bar, there is no guarantee of the security system's stable operation. Take all necessary precautions to ensure maximum signal level. At least try moving the device—even 20 cm can make a difference.

If after moving the device still has a low or unstable signal strength, use a [radio signal range extender](#).



The detector's light filter should be directed perpendicularly to the expected entry path to the room!

Make sure that no furniture, home plants, vases, decorative or glass structures are blocking the detector's field of view.



We recommend installing the detector at a height of 2.4 m

Installing the detector at any other height will narrow the detection zone, affecting the quality of motion detection.

Keep in mind that MotionProtect Curtain does not detect movement behind the glass. Therefore, do not install the detector in places where glass structures may block its range of view, e.g., in places where an open window may obstruct the device's field of view.

Detector Installation

Before installing the detector, make sure that you have chosen an appropriate location as indicated in this manual.

There are two options for installing MotionProtect Curtain:

- directly to a surface

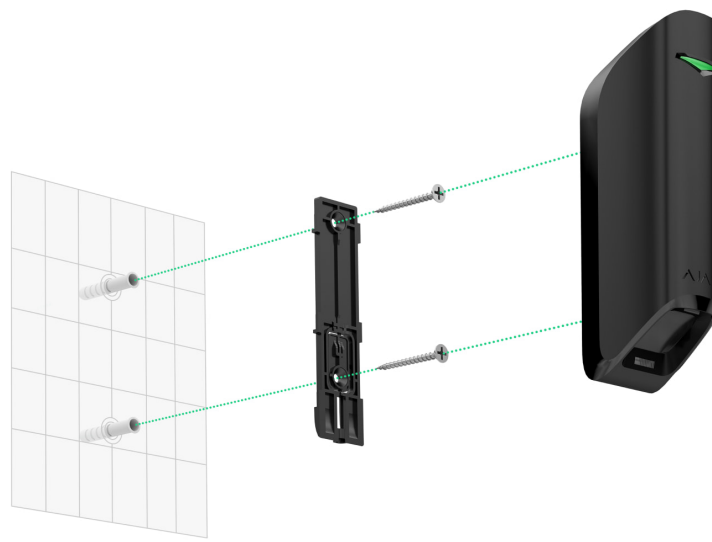

- to the included bracket.

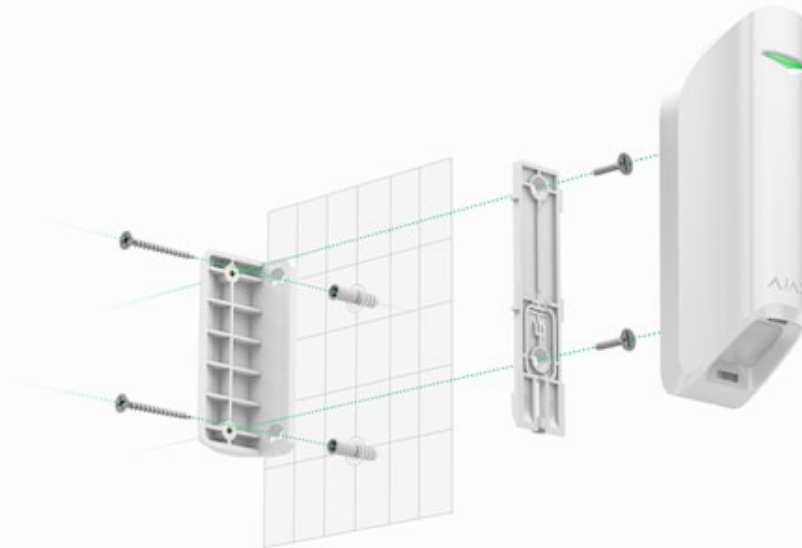

Installation procedure:

1. Attach the SmartBracket panel or a bracket to the surface with the included screws or other equally reliable fasteners. Screw the SmartBracket panel onto the included bracket.
2. Attach the detector to the SmartBracket attachment panel.
3. Mount the detector on the SmartBracket attachment panel using a screw.

The double-sided adhesive tape should be used only for the temporary installation of the detector. It will dry out eventually, becoming unable to reliably hold the detector and possibly causing false alarms in the security system. The fall of the device may also result in its damage.

If the detector's LED fails to light up after the device is attached to the SmartBracket, check the tamper status in the Ajax app and then check if it fits tightly onto the attachment panel. If you try to detach the detector from the surface or the panel, you will receive a notification.



Having installed the detector, run the [Detection Zone Test](#). In case of incorrect operation, the detector needs to be relocated.

Detector Care and Battery Replacement

Check the integrity of the MotionProtect Curtain detector regularly. Clean the detector body from dust, spider webs, and other contaminations as they appear. Use soft dry cloth suitable for equipment care.

Do not clean the detector with any substances containing alcohol, acetone, gasoline, or any other active solvent. Wipe the lens carefully and gently—any scratches on the plastic may reduce the detector's sensitivity.

The pre-installed battery ensures up to 3 years of autonomous operation (at a polling interval of 3 min). If the detector battery is nearly depleted, the security system will send a notification, and the LED will smoothly light up and go out when the detector detects any motion or if the tamper is activated.

How long Ajax devices operate on batteries, and what affects this

Battery replacement

Specifications

Sensor	PIR sensor, 2 pcs
--------	-------------------

Detection angles	Horizontal – 6°; vertical – 90°
Time for motion detection	From 0.3 to 2 m/s
Placement	Indoor only
Motion detection range	Up to 15/13/11 m (up to 8/7/6 m with Correlation Signal Processing enabled depending on sensitivity settings)
False alarm reduction	Available – Correlation Signal Processing
Tamper Protection	Available – detector body detachment and damage
Radio communication protocol	Jeweller Learn more
Radio frequency band	866.0 – 866.5 MHz 868.0 – 868.6 MHz 868.7 – 869.2 MHz 905.0 – 926.5 MHz 915.85 – 926.5 MHz 921.0 – 922.0 MHz Depends on the region of sale.
Compatibility	Operates only with all Ajax hubs , and radio signal range extenders
RF signal strength	Up to 20 mW
Radio signal modulation	GFSK
Radio signal range	Up to 1700 m line-of-sight
Power supply	1 battery CR123A, 3 V
Battery life	Up to 3 years
Installation method	Indoors only
Operating temperature range	From -10°C to +40°C
Protection class	IP54
Overall dimensions	134 × 44 × 34 mm
Weight	118 g
Service life	10 years

Complete Set

1. MotionProtect Curtain
2. SmartBracket panel
3. Battery CR123A (pre-installed)
4. Installation kit
5. Quick Start Guide
6. Bundled Bracket