



Wireless Access Point i9

User Guide

Copyright Statement

© 2018 Shenzhen Tenda Technology Co., Ltd. All rights reserved.

Tenda is a registered trademark legally held by Shenzhen Tenda Technology Co., Ltd. Other brand and product names mentioned herein are trademarks or registered trademarks of their respective holders. Copyright of the whole product as integration, including its accessories and software, belongs to Shenzhen Tenda Technology Co., Ltd. No part of this publication can be reproduced, transmitted, transcribed, stored in a retrieval system, or translated into any language in any form or by any means without the prior written permission of Shenzhen Tenda Technology Co., Ltd.

Disclaimer

Pictures, images and product specifications herein are for references only. To improve internal design, operational function, and/or reliability, Tenda reserves the right to make changes to the products without obligation to notify any person or organization of such revisions or changes. Tenda does not assume any liability that may occur due to the use or application of the product described herein. Every effort has been made in the preparation of this document to ensure accuracy of the contents, but all statements, information and recommendations in this document do not constitute a warranty of any kind, express or implied.

Preface



Thank you for choosing Tenda! Please read this user guide before you start with i9.

Conventions

The typographical elements that may be found in this document are defined as follows.

Item	Presentation	Example
Cascading menus	>	System > Live Users
Parameter and value	Bold	Set User Name to Tom.
Variable	Italic	Format: XX:XX:XX:XX:XX:XX
UI control	Bold	On the Policy page, click the OK button.
Message	“ ”	The “Success” message appears.

The symbols that may be found in this document are defined as follows.

Symbol	Meaning
 NOTE	This format is used to highlight information of importance or special interest. Ignoring this type of note may result in ineffective configurations, loss of data or damage to device.
 TIP	This format is used to highlight a procedure that will save time or resources.

Acronyms and abbreviations

Acronym or Abbreviation	Full Spelling
AP	Access Point
AC	Access Point Controller
SSID	Service Set Identifier
DHCP	Dynamic Host Configuration Protocol
DNS	Domain Name System
ISP	Internet Service Provider
AES	Advanced Encryption Standard
VLAN	Virtual Local Area Network
TKIP	Temporal Key Integrity Protocol

Acronym or Abbreviation	Full Spelling
PoE	Power Over Ethernet
WEP	Wired Equivalent Privacy

Additional information

For more information, search this product model on our website at <http://www.tendacn.com>.

Technical support

If you need more help, contact us by any of the following means. We will be glad to assist you as soon as possible.



Hotline

Global: (86) 755-27657180

Canada: 1-888-998-8966

Hong Kong: 00852-81931998



Email

support@tenda.cn



Website

<http://www.tendacn.com>



Skype

[tendasz](https://www.skype.com/zh-CN/add-to-list?contactid=tendasz)

Contents

1 Getting to know your device	1
1.1 Overview	1
1.2 Appearance	1
1.2.1 LED indicator	1
1.2.2 Button and port.....	2
1.2.3 Label	2
2 Application scenarios	4
2.1 Small scale WiFi network deployment.....	4
2.1.1 Deploying the AP with a Tenda router with the AP controller capacity	4
2.1.2 Deploying the AP with a router without the AP controller capacity	5
2.2 Large scale WiFi network deployment.....	6
3 Login	7
3.1 Logging in to the web UI of the AP	7
3.2 Logging out of the web UI of the AP	9
3.3 Web UI layout.....	9
3.4 Common buttons on the web UI.....	10
4 Quick Setup	11
4.1 Overview	11
4.2 Configuring AP mode	13
4.3 Configuring Client+AP mode	14
5 Status.....	16
5.1 System Status	16
5.2 Wireless Status.....	18
5.3 Traffic Statistics.....	19
5.4 Wireless Clients	20
6 Network settings	21
6.1 LAN setup	21

6.1.1 IP address obtaining mode – static IP address.....	22
6.1.2 IP address obtaining mode – dynamic IP address.....	23
6.2 DHCP server	25
6.2.1 Overview	25
6.2.2 Configuring the DHCP server	25
6.2.3 DHCP clients	27
7 Wireless Settings	28
7.1 Basic settings.....	28
7.1.1 Overview	28
7.1.2 Changing the SSID setup	30
7.1.3 Examples of configuring SSID setup.....	35
7.2 RF Settings.....	55
7.2.1 Overview	55
7.2.2 Changing the RF settings.....	55
7.3 Channel Scan	58
7.3.1 Overview	58
7.3.2 Checking the usage of channels.....	58
7.4 WMM Setup	59
7.4.1 Overview	59
7.4.2 Changing the WMM settings	60
7.5 Advanced.....	62
7.5.1 Overview	62
7.5.2 Changing the advanced settings	62
7.6 Access Control	65
7.6.1 Overview	65
7.6.2 Configuring access control	65
7.6.3 Example of configuring access control.....	66
7.7 QVLAN Settings	68
7.7.1 Overview	68
7.7.2 Configuring the QVLAN function.....	68

7.7.3 Example of configuring QVLAN settings.....	69
8 SNMP.....	72
8.1 Overview	72
8.1.1 SNMP management framework.....	72
8.1.2 Basic SNMP operations	72
8.1.3 SNMP protocol version	73
8.1.4 MIB introduction	73
8.2 Configuring the SNMP function	74
8.3 Example of configuring the SNMP function	75
Networking requirement	75
Configuration procedure	75
Verification	76
9 Tools	77
9.1 Firmware Upgrade	77
9.2 Time & Day.....	78
9.2.1 System Time	78
9.2.2 Login Timeout	80
9.3 Logs	81
9.3.1 View Logs	81
9.3.2 Log settings	82
9.4 Configuration.....	85
9.4.1 Backup & Restore	85
9.4.2 Restoring the Factory Settings	85
9.5 Account	87
9.6 Diagnostics Tool.....	88
9.7 Device Reboot	90
9.7.1 Manual Reboot.....	90
9.7.2 Automatic Reboot	90
9.8 LED Control.....	92

1 Getting to know your device

1.1 Overview

Tenda i9 is a wireless access point specially designed for offices, bars, coffee shops and other indoor environments. Working at 2.4 GHz band, it provides a wireless transmission rate of as high as 300 Mbps. Featured with 2 built-in high gain omni-directional MIMO antennas, i9 provides powerful WiFi signal with strong wall penetration capacity and broad WiFi coverage. Compliant with IEEE 802.3af standard, i9 allows you to apply long-distance power supply via PoE without changing your original power network. All of this makes i9 an ideal choice for WiFi coverage.

1.2 Appearance

1.2.1 LED indicator

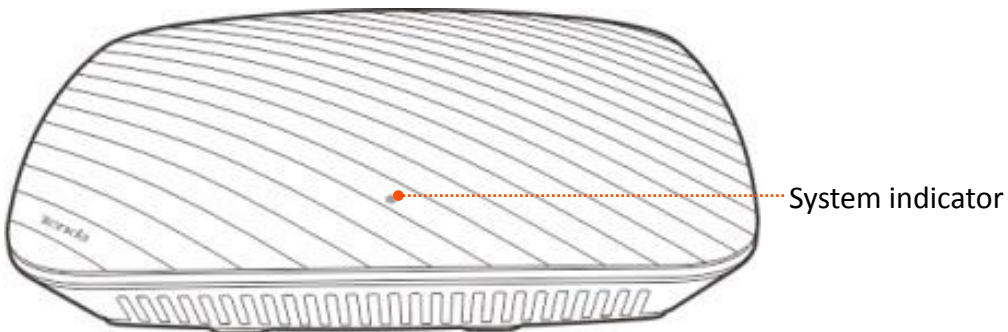

LED Indicator	Status	Description
System indicator	Solid on	The system is starting or faulty.
	Blinking	The system is working properly.
	Off	The system is powered off or the LED indicator is turned off.

1.2.2 Button and port

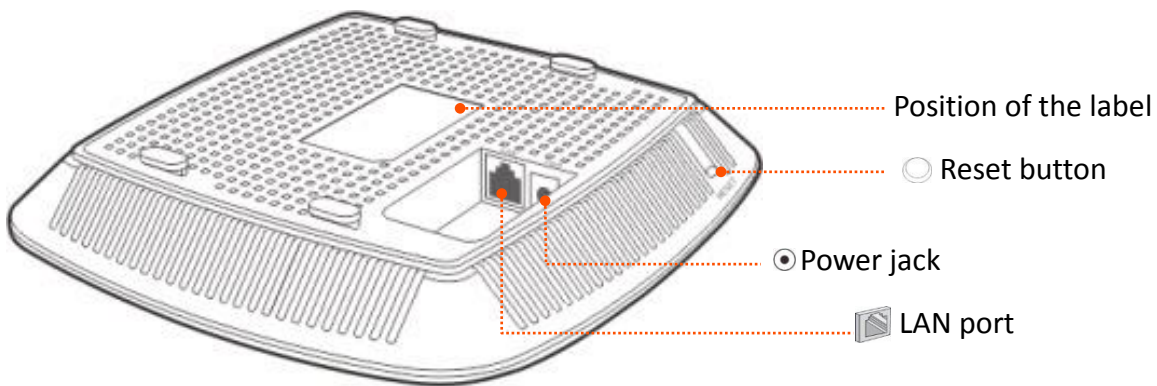

Button & Port	Connection Description
LAN port	<p>10/100 Mbps auto negotiation port</p> <ul style="list-style-type: none"> If the AP is powered using a DC adapter, connect this port to a switch. If the AP is powered through PoE, connect this port to an IEEE 802.3af PoE switch.
Power jack	<p>The power jack is used to connect to a DC adapter for supplying power to the AP.</p> <p>Input: 12 V 1 A</p>
Reset button	<p>After the AP is powered on, you can hold down this button for about 8 seconds to restore the factory settings.</p>

1.2.3 Label

The label is located on the rear panel of the AP. For details of the label, see the following figure.

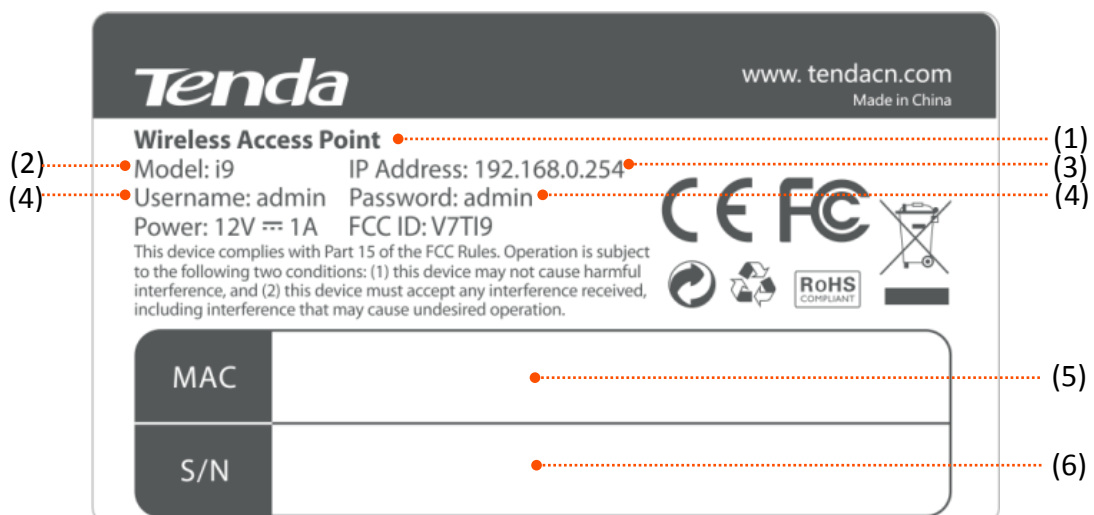

(1): Name of the AP.

(2): Model of the AP.

(3): Default IP address of the AP. You can use this IP address to log in to the web UI of the AP.

(4): Default user name and password of the web UI of the AP.

(5): MAC address of the AP. The default primary SSID of the AP is Tenda_XXXXXX, where XXXXXX indicates the last 6 characters of this MAC address.

(6): Serial number of the AP. If the AP is faulty, you need to provide this serial number when sending the AP for repair.

2 Application scenarios

2.1 Small scale WiFi network deployment

If you need to deploy a small scale WiFi network, you are recommended to use a wired router, a PoE switch, and several APs.

2.1.1 Deploying the AP with a Tenda router with the AP controller capacity

Networking topology

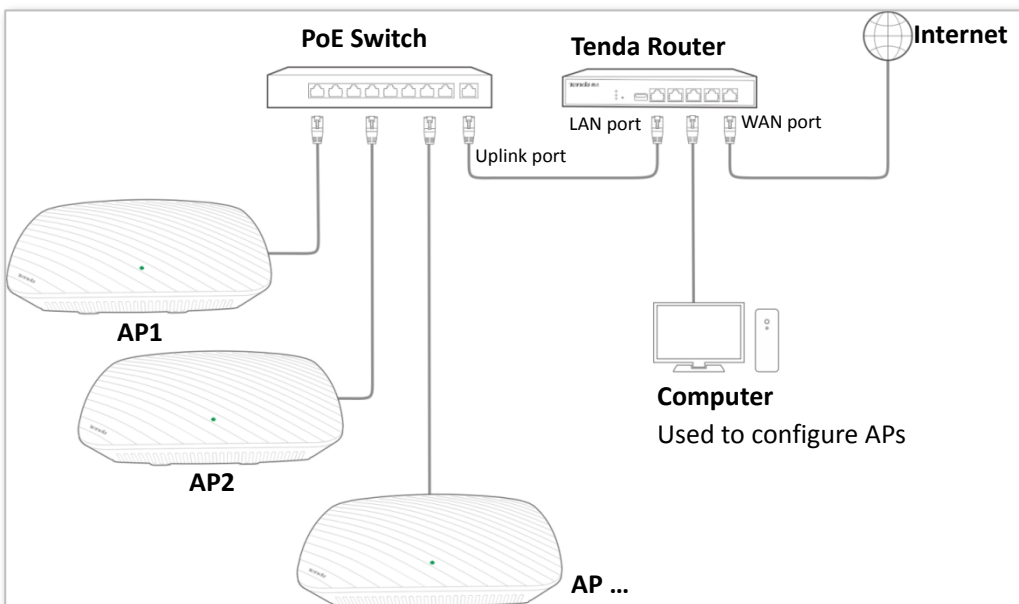

- Connect the LAN port of the AP to the PoE port of the switch.
- Connect the uplink port of the switch to a LAN port of the router.
- Connect the computer used to configure APs to a LAN port of the router.

Setting up the AP

Log in to the web UI of the router, and set up the APs in batch. Refer to the user guide of the router for details.

2.1.2 Deploying the AP with a router without the AP controller capacity

If you deploy the AP with a router without the AP controller capacity, refer to the following networking topology.

Networking topology

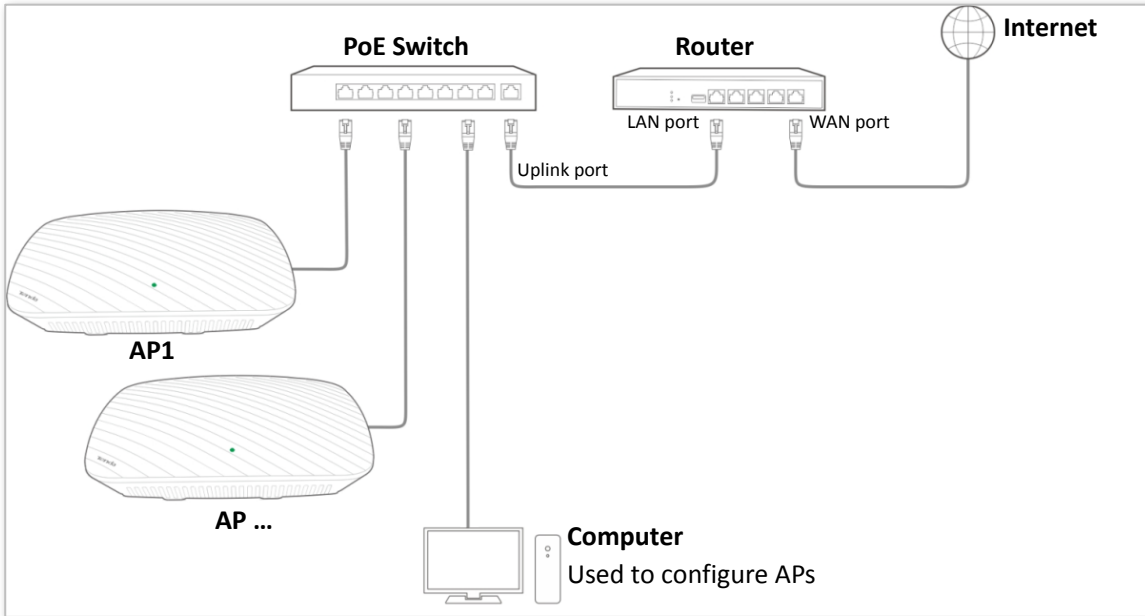

- Connect the uplink port of the switch to a LAN port of the router.
- Connect the computer used to configure APs to the switch.
- Connect an AP to the switch first. Then perform the same procedures to connect and configure the other APs.

Setting up the AP

Log in to the web UI of the first AP, and configure it. Then configure the other APs one by one.

Refer to [Chapter 3](#) and the follows in this user guide for details.



TIP

If multiple APs are needed to setup, change their IP addresses to different ones to avoid IP conflict.

2.2 Large scale WiFi network deployment

If you need to deploy a large scale WiFi network in hotels, enterprises, or stations, you are recommended to use a wired router, a PoE switch, a Tenda AP controller, and several APs.

Networking topology

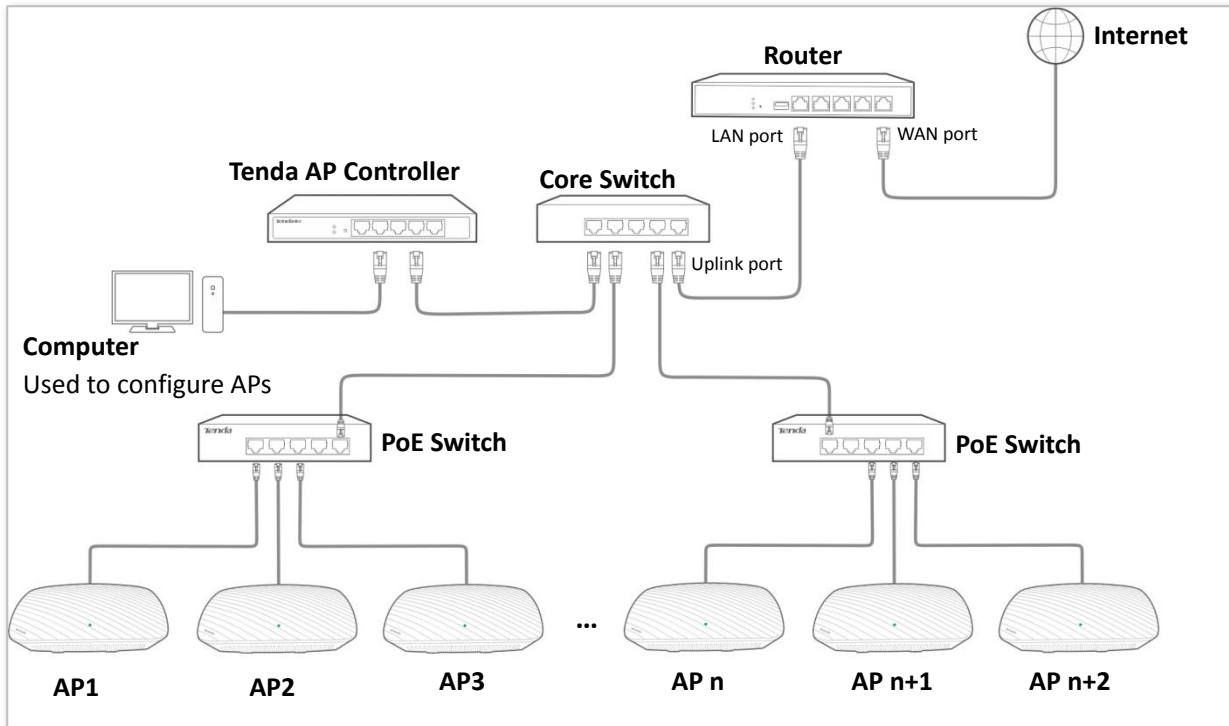

- Connect the computer used to configure APs to the Tenda AP controller.
- Connect the LAN port of the AP to the PoE port of the switch.

Setting up the AP

Log in to the web UI of the Tenda AP controller, and set up the APs in batch. Refer to the user guide of the Tenda AP controller for details.

3 Login

3.1 Logging in to the web UI of the AP

Step 1 Connect the computer to the AP or the switch connected to the AP.

Step 2 Set **IP address** of your local area connection to **192.168.0.X** (X: 2 - 253) and **Subnet mask** to **255.255.255.0**.

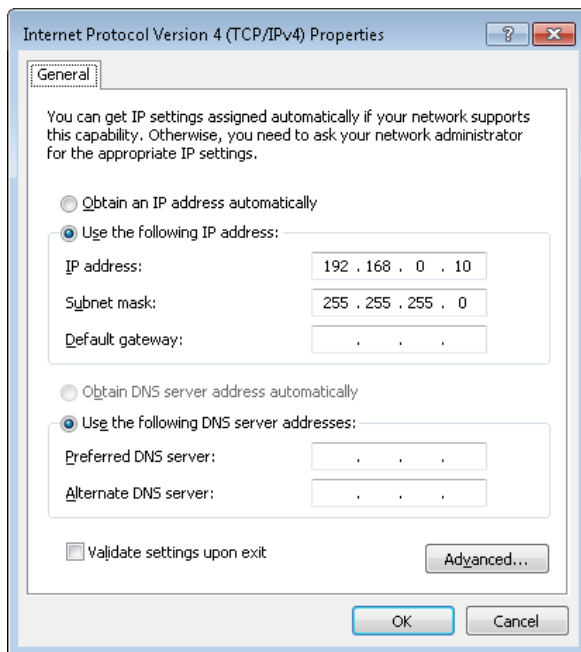

Step 3 Access **192.168.0.254** using a web browser.

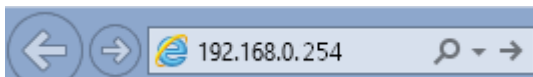

Step 4 Enter **admin** as the user name and password and click **Login**.

i9V2.0

👤

🔒

📍

▼

Login

[Forget your password?](#)



TIP

If this page is not displayed, refer to [Q1](#) in Appendix A "FAQ".

--End

You can now start configuring the AP.

<ul style="list-style-type: none"> <li style="padding: 5px;"> Status <li style="background-color: #e67e22; color: white; padding: 5px;">System Status <li style="padding: 5px;">Wireless Status <li style="padding: 5px;">Traffic Statistics <li style="padding: 5px;">Wireless Clients <li style="padding: 5px;"> Quick Setup <li style="padding: 5px;"> Network <li style="padding: 5px;"> Wireless <li style="padding: 5px;"> SNMP <li style="padding: 5px;"> Tools 	<div style="border-bottom: 1px solid #ccc; padding-bottom: 5px;"><u>System Status</u></div> <div style="text-align: right; margin-bottom: 10px;">Help</div> <table style="width: 100%; border-collapse: collapse;"> <tr><td colspan="2">System Status</td></tr> <tr><td style="padding: 5px;">AP Name</td><td style="padding: 5px;">i9V2.0</td></tr> <tr><td style="padding: 5px;">System Time</td><td style="padding: 5px;">2018-11-02 11:18:39</td></tr> <tr><td style="padding: 5px;">Uptime</td><td style="padding: 5px;">00h00m45s</td></tr> <tr><td style="padding: 5px;">Number of Clients</td><td style="padding: 5px;">0</td></tr> <tr><td style="padding: 5px;">Firmware Version</td><td style="padding: 5px;">V1.0.0.6(1020)</td></tr> <tr><td style="padding: 5px;">Hardware Version</td><td style="padding: 5px;">V2.0</td></tr> <tr><td colspan="2">LAN Status</td></tr> <tr><td style="padding: 5px;">MAC Address</td><td style="padding: 5px;">C8:3A:35:83:EF:D0</td></tr> <tr><td style="padding: 5px;">IP Address</td><td style="padding: 5px;">192.168.0.254</td></tr> <tr><td style="padding: 5px;">Subnet Mask</td><td style="padding: 5px;">255.255.255.0</td></tr> <tr><td style="padding: 5px;">Primary DNS Server</td><td style="padding: 5px;">192.168.0.252</td></tr> <tr><td style="padding: 5px;">Secondary DNS Server</td><td style="padding: 5px;">8.8.8.8</td></tr> </table>	System Status		AP Name	i9V2.0	System Time	2018-11-02 11:18:39	Uptime	00h00m45s	Number of Clients	0	Firmware Version	V1.0.0.6(1020)	Hardware Version	V2.0	LAN Status		MAC Address	C8:3A:35:83:EF:D0	IP Address	192.168.0.254	Subnet Mask	255.255.255.0	Primary DNS Server	192.168.0.252	Secondary DNS Server	8.8.8.8
System Status																											
AP Name	i9V2.0																										
System Time	2018-11-02 11:18:39																										
Uptime	00h00m45s																										
Number of Clients	0																										
Firmware Version	V1.0.0.6(1020)																										
Hardware Version	V2.0																										
LAN Status																											
MAC Address	C8:3A:35:83:EF:D0																										
IP Address	192.168.0.254																										
Subnet Mask	255.255.255.0																										
Primary DNS Server	192.168.0.252																										
Secondary DNS Server	8.8.8.8																										

3.2 Logging out of the web UI of the AP

After you log in to the web UI of the AP, the system logs you out if you perform no operation on the web UI within the [Login Timeout](#) interval. (The default interval is 5 minutes and can be changed.)

When you close the web browser, the system logs you out as well.

When you are logged out, the system does not save the current configuration. Therefore, you are recommended to save the current configuration before logging out.



TIP

If you close the web browser tab page used to log in to the web UI of the AP instead of the web browser, you are not logged out.

3.3 Web UI layout

The web UI of the AP is composed of 4 parts, including the level-1 navigation tree, level-2 navigation tree, tab page area, and configuration area. See the following figure.



TIP

The functions and parameters dimmed on the web UI indicates that they are not supported by the AP or cannot be changed in the current configuration.

The screenshot displays the web UI of the AP. It features a navigation tree on the left (labeled 1) with items like System Status, Wireless Status, Traffic Statistics, Wireless Clients, Quick Setup, Network, Wireless, SNMP, and Tools. The main content area (labeled 3) shows the 'System Status' page. The 'System Status' page includes a 'Help' button and a table of system information. The 'Number of Clients' field is highlighted with a red circle (labeled 4). The 'LAN Status' section is also visible.

System Status	
AP Name	i9V2.0
System Time	2018-11-02 11:18:39
Uptime	00h00m45s
Number of Clients	0
Firmware Version	V1.0.0.6(1020)
Hardware Version	V2.0
LAN Status	
MAC Address	C8:3A:35:83:EF:D0
IP Address	192.168.0.254
Subnet Mask	255.255.255.0
Primary DNS Server	192.168.0.252
Secondary DNS Server	8.8.8.8

No.	Name	Description
1	Level-1 navigation tree	The navigation bars display the function menu of the AP. When you select a function in navigation bar, the configuration of the function appears in the configuration area.
2	Level-2 navigation tree	
3	Tab page area	
4	Configuration area	It enables you to view and modify configuration.

3.4 Common buttons on the web UI

Description of common buttons:

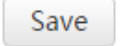
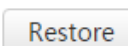
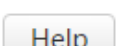
Button	Description
	It is used to update the content of the current page.
	It is used to save the configuration on the current page and enable the configuration to take effect.
	It is used to change the current configuration on the current page back to the original configuration.
	It is used to view help information corresponding to the settings on the current page.

4 Quick Setup

4.1 Overview

This module enables you to quickly configure the AP so that wireless devices such as smart phones and pads can access the internet through the wireless network of the AP.

This AP can work in [AP](#) or [Client+AP](#) mode.

■ AP mode

By default, the AP works in this mode. In this mode, the AP connects to the internet using an Ethernet cable and converts wired signals into wireless signals to provide wireless network coverage. See the following topology.

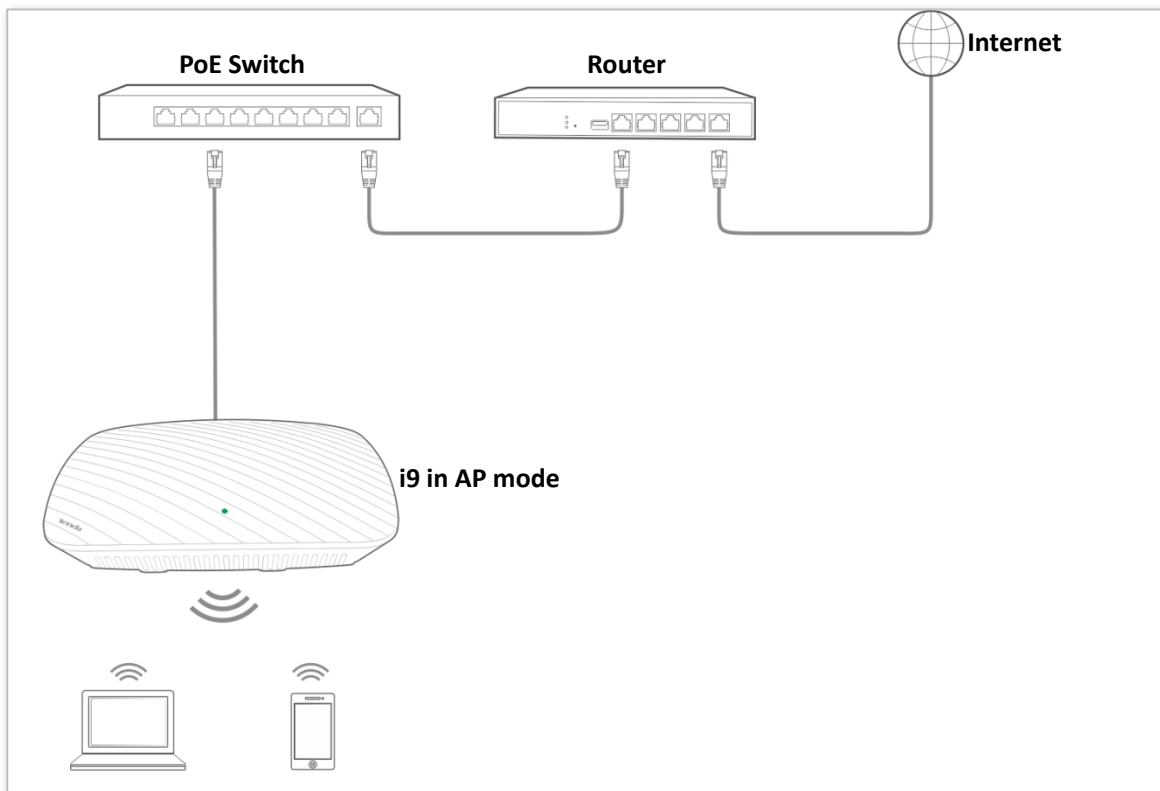

■ **Client+AP mode**

In this mode, the AP is wirelessly bridged to an upstream device (such as a wireless router or AP) to extend the wireless network coverage of the upstream device. See the following topology.

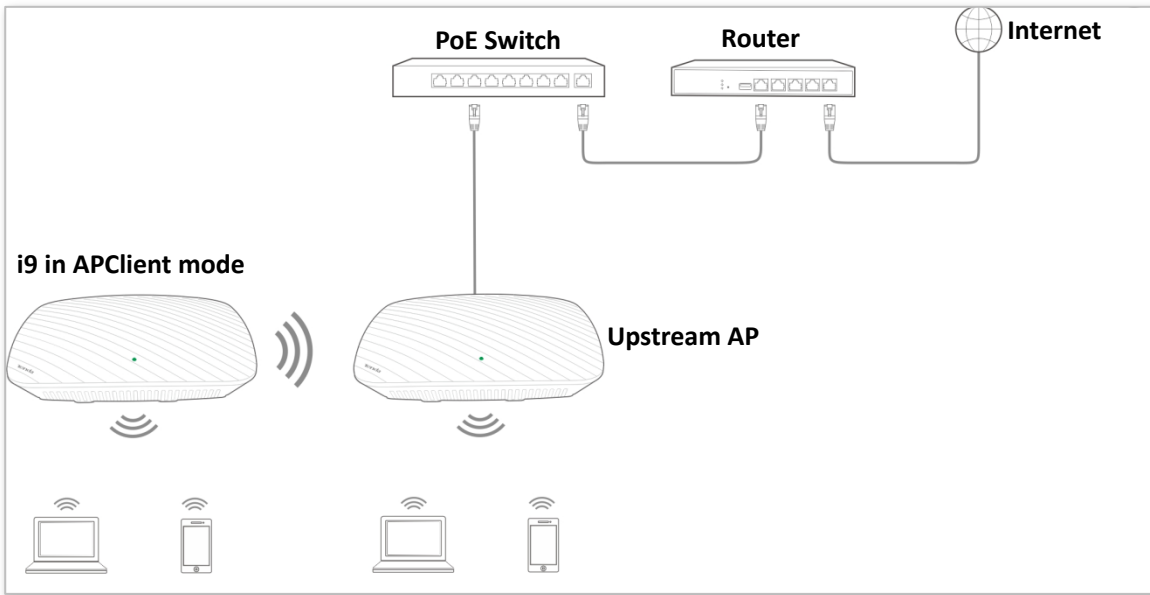

4.2 Configuring AP mode

The Mixed WPA/WPA2-PSK security mode and AES encryption algorithm are used as an example to describe the configuration procedure. If you need to use another security mode, refer to Section [7.1 Basic settings](#).

Configuration procedure:

Step 1 Set **Working Mode** to **AP**.

Step 2 (Optional) Set **SSID** to a wireless network name.

Step 3 Set **Security Mode** to **Mixed WPA/WPA2-PSK**, **Encryption Algorithm** to **AES**, and **Key** to the password of the wireless network.

Step 4 Click **Save**.

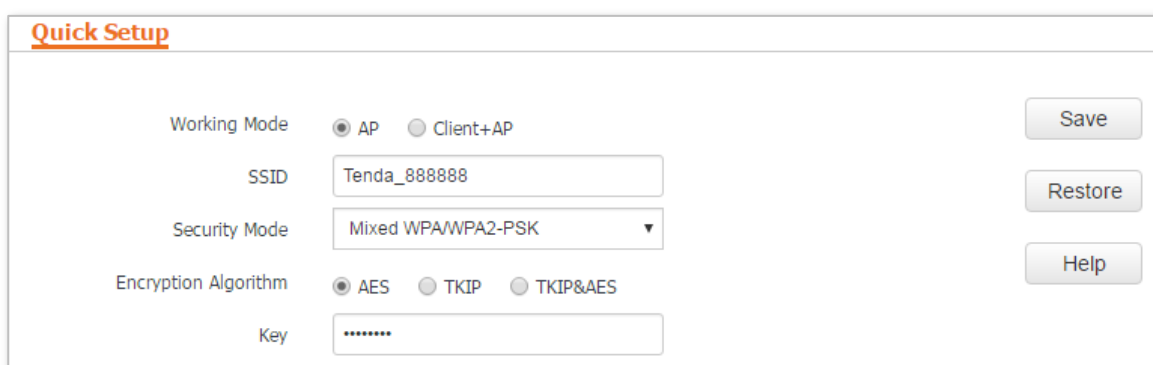

Quick Setup

Working Mode AP Client+AP

SSID

Security Mode

Encryption Algorithm AES TKIP TKIP&AES

Key

Save

Restore

Help

--End

Parameter description

Parameter	Description
Working Mode	It specifies the working mode of the AP, including AP mode and Client+AP mode.
SSID	It specifies the primary SSID (wireless network name) of the wireless network at the corresponding radio band.
Security Mode	It specifies the security mode of the wireless network, including: None, WEP, WPA-PSK, WPA2-PSK, Mixed WPA/WPA2-PSK, WPA, and WPA2. Clicking the hyperlink navigates you to the elaborated description of the corresponding security mode.

After the configuration, you can select the SSID on your wireless devices such as smart phones and enter your wireless network password to connect to the wireless network of the AP and access the internet through the AP.

4.3 Configuring Client+AP mode

Configuration procedure:



Before configuration, ensure that the upstream AP is connected to the internet successfully.

Assume that the upstream AP has the basic information described in the following table.

IP Address	SSID	Security Mode	Security Key (Wireless Network Password)
192.168.0.254	Tenda_1	WPA2-PSK	87654321

- Step 1** Log in to the web UI of this AP, and change its IP address to an unused IP address belonging to the same network segment as that of the upstream AP, such as 192.168.0.253. For details, refer to Section [6.1 LAN Setup](#).
- Step 2** Use the new IP address to log in to the web UI of this AP, and choose **Quick Setup**.
- Step 3** Set the **Working Mode** to **Client+AP**.
- Step 4** Click **Scan**.
- Step 5** Select the SSID of the upstream AP from the detected SSIDs, which is **Tenda_1** in this example.



If the AP detects no wireless network, choose **Wireless > Basic** to enable the wireless function, and then try again.

- Step 6** After you select an SSID, the SSID, Security Mode, Encryption Algorithm, and Upstream AP Channel are populated automatically. You just need to enter the password of the wireless network of the upstream AP in the **Key** box. Set **Key** to the wireless network password of the upstream AP, which is **87654321** in this example.
- Step 7** Click **Save**.

Quick Setup

Working Mode AP Client+AP

SSID

Security Mode

Encryption Algorithm AES TKIP TKIP&AES

Key

Upstream AP Channel

Select	SSID	MAC Address	Network Mode	Channel Bandwidth	Channel	Extension Channel	Security Mode
<input checked="" type="radio"/>	Tenda_1	50:2b:73:09:94:51	bgn	40	11	upper	wpa2/aes

--End

Parameter description

Parameter	Description
Working Mode	It specifies the working mode of the AP, including AP Mode and Client+AP Mode.
SSID	It specifies the SSID (wireless network name) of the upstream AP to be bridged. It is populated automatically when you select the SSID of the upstream AP.
Security Mode	It specifies the security mode of the wireless network to be bridged. The AP can bridge to a wireless network using None, WEP (Open or shared), WPA-PSK, WPA2-PSK, or Mixed WPA/WPA2-PSK security mode. Clicking the hyperlink navigates you to the elaborated description of the corresponding security mode.
Authentication Type	It specifies the WEP authentication type of the wireless network to be bridged. It needs to be manually entered.
Default Key	It specifies the WEP default key (wireless password) of the wireless network to be bridged. It needs to be manually entered.
WEP Key 1 to 4	It specifies the WEP key of the wireless network to be bridged. It needs to be manually entered.
Encryption Algorithm	It specifies the WPA cipher type of the wireless network to be bridged. It is populated automatically when you select the SSID of the upstream AP.
Key	It specifies the wireless password of the wireless network to be bridged. It needs to be manually entered.
Upstream AP Channel	It specifies the wireless channel used by the upstream AP. It is populated automatically when you select the SSID of the upstream AP.

After the settings take effect, use your smart phone to search the SSID of this AP, and enter the key for internet access. Choose **Wireless > Basic** to check or change the SSID and key.

5 Status

5.1 System Status

To view the system status and LAN status of the AP, choose **Status > System Status**.

System Status

[Help](#)

AP Name	i9V2.0
System Time	2018-11-02 11:18:39
Uptime	00h00m45s
Number of Clients	0
Firmware Version	V1.0.0.6(1020)
Hardware Version	V2.0

LAN Status

MAC Address	C8:3A:35:83:EF:D0
IP Address	192.168.0.254
Subnet Mask	255.255.255.0
Primary DNS Server	192.168.0.252
Secondary DNS Server	8.8.8.8

Parameter description

Parameter	Description
AP Name	It specifies the name of the AP. A unique Device Name helps quickly identify the AP. You can change the Device Name on the Network > LAN Setup page.
System Time	It specifies the current system time of the AP.
Uptime	It specifies the time that has elapsed since the AP was started last time.
Number of Clients	It specifies the number of wireless clients currently connected to the AP.
Firmware Version	It specifies the firmware version number of the AP.

Parameter	Description
Hardware Version	It specifies the hardware version number of the AP.
MAC Address	It specifies the physical address of the LAN port of the AP. If you connect the AP to other devices using Ethernet cables, the AP uses this MAC address to communicate with those devices.
IP Address	It specifies the IP address of the AP. The web UI of the AP is accessible at this IP address. You can change the IP address on the Network > LAN Setup page.
Subnet Mask	It specifies the subnet mask of the IP address of the AP.
Primary DNS Server	It specifies the primary DNS server of the AP.
Secondary DNS Server	It specifies the secondary DNS server of the AP.

5.2 Wireless Status

To view the radio status and SSID status of the wireless network, choose **Status > Wireless Status**.

Wireless Status			
RF Status			Help
RF (On/Off)	On		
Network Mode	b/g/n		
Channel	4		
SSID Status			
SSID	MAC Address	Enabled/Disabled	Security Mode
Tenda_1	C8:3A:35:83:EF:D1	Enabled	WPA2-PSK
Tenda_83EFD1	C8:3A:35:83:EF:D2	Disabled	None
Tenda_83EFD2	C8:3A:35:83:EF:D3	Disabled	None
Tenda_83EFD3	C8:3A:35:83:EF:D4	Disabled	None

Parameter description

Parameter	Description	
RF Status	RF (On/Off)	It specifies whether the wireless function of the AP is enabled.
	Network Mode	It specifies the current network mode of the AP.
	Channel	It specifies the current working channel of the AP.
SSID Status	SSID	It specifies the names of all the wireless networks of the AP.
	MAC Address	It specifies the physical addresses corresponding to the SSIDs of the AP.
	Enable/Disable	It specifies whether the wireless networks corresponding to the SSIDs of the AP are enabled.
	Security Mode	It specifies the security modes of the wireless networks corresponding to the SSIDs of the AP.

5.3 Traffic Statistics

To view the total transmitted traffic, total received traffic, total number of transmitted packets, and total number of received packets corresponding to each SSID of the AP, choose **Status > Traffic Statistics**.

<u>Traffic Statistics</u>				
SSID	Received Traffic	Received Packets	Transmitted Traffic	Transmitted Packets
Tenda_1	22.78MB	105400	0.38MB	1667
Tenda_888889	0.00MB	0	0.00MB	0
Tenda_88888A	0.00MB	0	0.00MB	0
Tenda_88888B	0.00MB	0	0.00MB	0

Help

Refresh

You can click **Refresh** to view the latest traffic statistics.

5.4 Wireless Clients

To view the MAC address, IP address, connection uptime, transmit speed, and receive speed of each wireless client connected to the AP, choose **Status > Wireless Clients**.

Wireless Clients

You can view information about the wireless devices that are connected to the wireless networks of the AP. Help

Connected Hosts:

ID	MAC Address	IP	Connection Uptime	Transmit Speed	Receive Speed
1	1C:5C:F2:B4:40:08	192.168.0.133	00h00m42s	144.5Mbps	24Mbps

You can select an SSID from the drop-down list box in the upper-right corner to view information about the wireless clients connected to the AP using the SSID.

6 Network settings

6.1 LAN setup

To view or configure the MAC address, device name, IP address obtaining mode, and other related information of the LAN port of the AP, choose **Network > LAN Setup**.

LAN Setup

MAC Address: C8:3A:35:83:EF:D0

IP Address Type: Static

IP Address: 192.168.0.254 (Example: 192.168.1.254)

Subnet Mask: 255.255.255.0 (Example: 255.255.255.0)

Gateway: 192.168.0.1

Primary DNS Server: 8.8.8.8

Secondary DNS Server: (optional)

AP Name: i9V2.0

Driving Capability of Port: Standard Enhanced (lower port speed)

Buttons: Save, Restore, Help

Parameter description

Parameter	Description
MAC Address	It specifies the MAC address of the LAN port of the AP. The default primary SSID of the AP is Tenda_XXXXXX, where XXXXXX indicates the last 6 characters of this MAC address.
IP Address Type	It specifies the IP address obtaining mode of the AP. The default option is Static IP . <ul style="list-style-type: none">• Static: It indicates that the IP address, subnet mask, gateway, and DNS server information of the AP is set manually.• Dynamic: It indicates that the IP address, subnet mask, gateway, and DNS server information of the AP is obtained from a DHCP server in your LAN. If IP Address Type is set to Dynamic , you can log in to the web UI of the AP only with the IP address assigned to the AP by the DHCP server. The IP address is specified on the client list of the DHCP server.
IP Address	It specifies the IP address of the AP if IP Address Type is set to Static . The default IP address is 192.168.0.254 and you can change it as required.

Parameter	Description
	 <p>This IP address also functions as the management IP address of the AP. You can use this IP address to log in to the web UI of the AP to manage the AP.</p>
Subnet Mask	It specifies the subnet mask of the IP address of the AP if IP Address Type is set to Static . The default subnet mask is 255.255.255.0 and you can change it as required.
Gateway	It specifies the gateway of the AP if IP Address Type is set to Static . The default gateway IP address is 192.168.0.1 and you can change it as required.
Primary DNS Server	It specifies the primary DNS server of the AP if IP Address Type is set to Static . The default IP address of the primary DNS server is 8.8.8.8 and you can change it as required.
Secondary DNS Server	It specifies the secondary DNS server of the AP if IP Address Type is set to Static . This IP address is optional.
AP Name	<p>It specifies the device name of the AP. The default device name is in the format of <i>Model + Hardware version number</i>.</p> <p>You are recommended to change the device name so that you can quickly locate the AP when managing the AP remotely.</p>
Driving Capability of Port	<p>It specifies the Ethernet mode of LAN of this AP.</p> <ul style="list-style-type: none"> • Standard: This mode features a high transmission rate but short transmission distance. Generally, this mode is recommended. • Enhanced (lower port speed): This mode features a long transmission distance but relatively low transmission rate (10 Mbps). <p>This mode is recommended only if the Ethernet cable that connects the LAN port of the AP to a peer device exceeds 100 meters. In this case, the connected LAN port of the peer device must work in auto-negotiation mode. Otherwise, the LAN port of the AP may not be able to properly transmit or receive data.</p>



If you change the IP address of the LAN port, change the IP address of your management computer as well so that the two IP addresses belong to the same network segment. Then, use the new IP address of the LAN port to log in to the web UI of the AP.

6.1.1 IP address obtaining mode – static IP address

This mode enables you to set the IP address, subnet mask, gateway IP address, primary DNS server, and secondary DNS server of the AP. It is applicable to a scenario with only one or a few APs.

Configuration procedure:

- Step 1** Set **IP Address Type** to **Static**.
- Step 2** Set **IP Address**.
- Step 3** Set **Subnet Mask** to the subnet mask of the IP address. Generally the subnet mask is 255.255.255.0.
- Step 4** Set **Gateway** to the IP address of the gateway of the AP.
- Step 5** Set **Primary DNS Server** to the IP address of the primary DNS server of the AP. If another DNS server is available, set **Secondary DNS Server** to the IP address of the additional DNS server.
- Step 6** Click **Save**.

LAN Setup

MAC Address	C8:3A:35:83:EF:D0		Save
IP Address Type	Static		Restore
IP Address	192.168.0.254	Example: 192.168.1.254	Help
Subnet Mask	255.255.255.0	Example: 255.255.255.0	
Gateway	192.168.0.1		
Primary DNS Server	8.8.8.8		
Secondary DNS Server		(optional)	
AP Name	i9V2.0		
Driving Capability of Port	<input checked="" type="radio"/> Standard <input type="radio"/> Enhanced (lower port speed)		

--End

6.1.2 IP address obtaining mode – dynamic IP address

This mode enables the AP to automatically obtain an IP address, subnet mask, gateway IP address, primary DNS server IP address, and secondary DNS server IP address from a DHCP server in the network. If a large number of APs are deployed, you can adopt this mode to prevent IP address conflicts and effectively reduce your workload.

Configuration procedure:

- Step 1** Set **IP Address Type** to **Dynamic**.
- Step 2** Click **Save**.

LAN Setup

MAC Address C8:3A:35:83:EF:D0

IP Address Type

AP Name

Driving Capability of Port Standard Enhanced (lower port speed)

Save

Restore

Help

--End

6.2 DHCP server

6.2.1 Overview

The AP provides a DHCP server function to assign IP addresses to clients on the LAN. By default, the DHCP server function is disabled.



If the new and original IP addresses of the LAN port belong to different network segment, the system changes the IP address pool of the DHCP server function of the AP so that the IP address pool and the new IP address of the LAN port belong to the same network segment.



6.2.2 Configuring the DHCP server

- Step 1** Select the **Enable** check box of **DHCP Server**.
- Step 2** Set **Start IP Address** to the start IP address of the IP address pool, which contains the IP addresses that can be assigned by the DHCP server to clients.
- Step 3** Set **End IP Address** to the end IP address of the IP address pool.
- Step 4** Set **Lease Time** to the time when an IP address is available to a client. The default option **1 day** is recommended.
- Step 5** Set **Subnet Mask** to the subnet mask of the IP addresses. The default value **255.255.255.0** is recommended.
- Step 6** Set **Gateway** to the gateway IP address to be assigned by the DHCP server to clients.
- Step 7** Set **Primary DNS Server** to the IP address of the primary DNS server assigned by the DHCP server to clients. If another DNS server IP address is available, set **Secondary DNS Server** to that IP address.
- Step 8** Click **Save**.

<u>DHCP Server</u>		<u>DHCP Clients</u>	
DHCP Server	<input checked="" type="checkbox"/> Enable		Save
Start IP Address	<input type="text" value="192.168.0.100"/>		Restore
End IP Address	<input type="text" value="192.168.0.200"/>		
Lease Time	<input type="text" value="1 day"/>		Help
Subnet Mask	<input type="text" value="255.255.255.0"/>		
Gateway	<input type="text" value="192.168.0.1"/>		
Primary DNS Server	<input type="text" value="8.8.8.8"/>		
Secondary DNS Server	<input type="text" value="8.8.4.4"/>	(optional)	

--End

Parameter description

Parameter	Description
DHCP Server	It specifies whether to enable the DHCP server function. To enable it, select the check box. To disable it, deselect the check box. By default, it is disabled.
Start IP Address	It specifies the first IP address that can be assigned by the DHCP server to a client. The default value is 192.168.0.100 .
End IP Address	It specifies the last IP address that can be assigned by the DHCP server to a client. The default value is 192.168.0.200 .
Lease Time	It specifies the validity period of an IP address assigned by the DHCP server to a client. The default value is 1 day .
Subnet Mask	It specifies the subnet mask assigned by the DHCP server to clients. The default value is 255.255.255.0 .
Gateway	<p>It specifies the gateway IP address assigned by the DHCP server to clients. The default value is 192.168.0.1.</p> <p> NOTE</p> <p>When a client accesses a server or host located outside the network segment where the client resides, the data from and to the client must be forwarded by the gateway. Generally, the IP address of the gateway is the LAN IP address of the router in your LAN.</p>
Primary DNS Server	<p>It specifies the primary DNS server IP address assigned by the DHCP server to clients. The default value is 8.8.8.8.</p> <p> NOTE</p> <p>To enable clients to access web pages using domain names, set this parameter to a correct DNS server IP address or DNS proxy IP address.</p>
Secondary DNS Server	It specifies the secondary DNS server IP address assigned by the DHCP server to clients. This IP address is optional.



If another DHCP server is available in your LAN, ensure that the IP address pool of the AP does not overlap the IP address pool of that DHCP server. Otherwise, IP address conflict may occur.

6.2.3 DHCP clients

If the AP functions as a DHCP server, you can view the DHCP client list to understand the details about the clients that obtain IP addresses from the DHCP server. The details include host names, IP addresses, MAC addresses, and lease times.

To view information about the clients that obtain IP addresses from the DHCP server function of the AP, choose **Network > DHCP Server** and click the **DHCP Clients** tab.

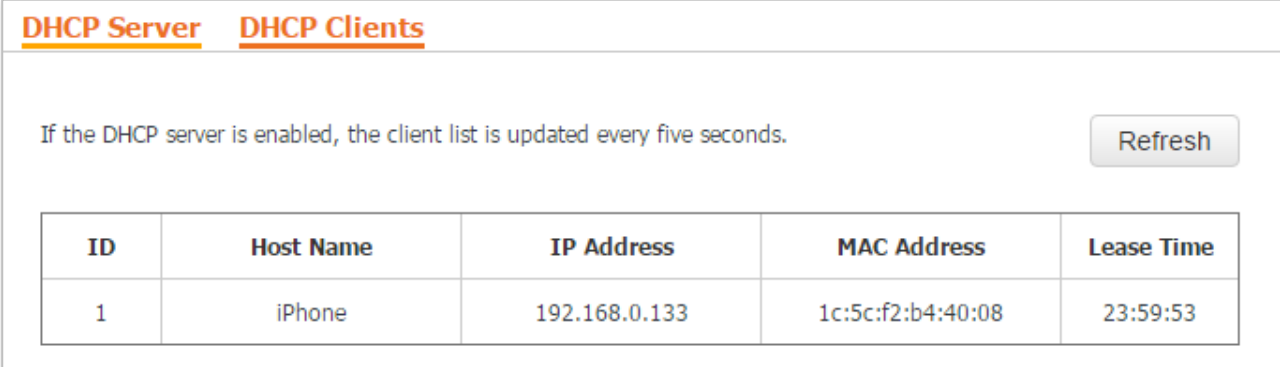

DHCP Server **DHCP Clients**

If the DHCP server is enabled, the client list is updated every five seconds. Refresh

ID	Host Name	IP Address	MAC Address	Lease Time
1	iPhone	192.168.0.133	1c:5c:f2:b4:40:08	23:59:53

You can click **Refresh** to view the latest client information.

7 Wireless Settings

7.1 Basic settings

This module enables you to set SSID-related parameters of wireless networks of your AP.

7.1.1 Overview

■ Broadcast SSID

When the AP broadcasts an SSID, nearby wireless clients can detect the SSID. When this parameter is set to **Disable**, the AP does not broadcast the SSID and nearby wireless clients cannot detect the SSID. In this case, you need to enter the SSID manually on your wireless client if you want to connect to the wireless network corresponding to the SSID. This to some extent enhances the security of the wireless network.

It is worth noting that after **Broadcast SSID** is set to **Disable**, a hacker can still connect to the corresponding wireless network if he/she manages to obtain the SSID by other means.

■ Isolate Client

This parameter implements a function similar to the VLAN function for wired networks. It isolates the wireless clients connected to the same wireless network corresponding to an SSID, so that the wireless clients can access only the wired network connected to the AP. Applying this function to hotspot setup at public places such as hotels and airports helps increase network security.

■ WMF

The number of wireless clients keeps increasing currently, but wired and wireless bandwidth resources are limited. Therefore, the multicast technology, which enables single-point data transmission and multi-point data reception, has been widely used in networks to effectively reduce bandwidth requirements and prevent network congestion.

Nevertheless, if a large number of clients are connected to a wireless interface of a wireless network and multicast data is intended for only one of the clients, the data is still sent to all the clients, which unnecessarily increases wireless resource usage and may lead to wireless channel congestion. In addition, multicast stream forwarding over an IEEE 802.11 network is not secure.

The WMF function of the AP converts multicast traffic into unicast traffic and forwards the traffic to the multicast traffic destination in the wireless network. This helps save wireless resources, ensure reliable transmission, and reduce delays.

■ Max. Number of Clients

This parameter specifies the maximum number of clients that can connect to the wireless network corresponding to an SSID. If the number is reached, the wireless network rejects new connection requests from clients. This limit helps balance load among APs.

■ Security Mode

A wireless network uses radio, which is open to the public, as its data transmission medium. If the wireless network is not protected by necessary measures, any client can connect to the network to use the resources of the network or access unprotected data over the network. To ensure communication security, transmission links of wireless networks must be encrypted for protection.

The AP supports various security modes for network encryption, including **None**, **WEP**, **WPA-PSK**, **WPA2-PSK**, **Mixed WPA/WPA2-PSK**, **WPA**, and **WPA2**.

– None

It indicates that any wireless client can connect to the wireless network. This option is not recommended because it affects network security.

– WEP

It uses a static key to encrypt all exchanged data, and ensures that a wireless LAN has the same level of security as a wired LAN. Data encrypted based on WEP can be easily cracked. In addition, WEP supports a maximum wireless network throughput of only 54 Mbps. Therefore, this security mode is not recommended.

– WPA-PSK, WPA2-PSK, and Mixed WPA/WPA2-PSK

They belong to pre-shared key or personal key modes, where Mixed WPA/WPA2-PSK supports both WPA-PSK and WPA2-PSK.

WPA-PSK, WPA2-PSK, and Mixed WPA/WPA2-PSK adopt a pre-shared key for authentication, while the AP generates another key for data encryption. This prevents the vulnerability caused by static WEP keys, and makes the three security modes suitable for ensuring security of home wireless networks. Nevertheless, because the initial pre-shared key for authentication is manually set and all clients use the same key to connect to the same AP, the key may be disclosed unexpectedly. This makes the security modes not suitable for scenarios where high security is required.

– WPA and WPA2

To address the key management weakness of WPA-PSK and WPA2-PSK, the WiFi Alliance puts forward WPA and WPA2, which use 802.1x to authenticate clients and generate data encryption-oriented root keys. WPA and WPA2 use the root keys to replace the pre-shared keys that set manually, but adopt the same encryption process as WPA-PSK and WPA2-PSK.

WPA and WPA2 uses 802.1x to authenticate clients and the login information of a client is managed by the client. This effectively reduces the probability of information leakage. In addition, each time a client connects to an AP that adopts the WPA or WPA2 security mode, the RADIUS server generates a data encryption key and assigns it to the client. This makes it difficult for attackers to obtain the key. These features of

WPA and WPA2 help significantly increase network security, making WPA and WPA2 the preferred security modes of wireless networks that require high security.

7.1.2 Changing the SSID setup

To change the basic settings of an SSID, perform the following procedure:

- Step 1** Choose **Wireless > Basic**.
- Step 2** Select the SSID from the SSID drop-down list box.
- Step 3** Change the parameters as required. Generally, you only need to change the **Enable**, **SSID**, and **Security Mode** settings.
- Step 4** Click **Save**.

The screenshot shows the 'Basic' configuration page for wireless settings. The 'Broadcast SSID' dropdown menu is highlighted with a red border. The current selection is 'Enable'. Other visible settings include: SSID (Tenda_888888), Enable (checked), Isolate Client (Disable), WMF (Disable), Max. Number of Clients (48), Chinese SSID Encoding (UTF-8), Security Mode (Mixed WPA/WPA2-PSK), Encryption Algorithm (AES), Key (masked), and Key Update Interval (0). Buttons for 'Save', 'Restore', and 'Help' are located on the right side of the form.

--End

Parameter description

Parameter	Description
SSID	It specifies the SSID to be configured. The AP allows 4 SSIDs. The default SSID is the primary SSID of the AP, which is Tenda_XXXXXX, where XXXXXX indicates the last 6 characters in the MAC address specified on the label on the external surface of the AP.
Enable	It specifies whether to enable the selected SSID. By default, the primary SSID is enabled and the other SSIDs are disabled. You can enable them as required.

Parameter	Description
Broadcast SSID	<p>It specifies whether to broadcast the selected SSID.</p> <ul style="list-style-type: none"> • Enable: It indicates that the AP broadcasts the SSID and the SSID can be detected by clients. • Disable: It indicates that the AP does not broadcast the SSID and the SSID cannot be detected by clients. If a user wants to connect to the wireless network corresponding to this SSID, the user must enter the SSID manually. <p> NOTE This AP can automatically hide its SSID. When the number of clients connected to the AP with an SSID of the AP reaches the Maximum Clients, the AP stops broadcasting the SSID.</p>
Isolate Client	<p>It specifies whether to isolate the wireless clients connected to the AP with the selected SSID.</p> <ul style="list-style-type: none"> • Enable: It indicates that the wireless clients connected to the AP with the selected SSID cannot communicate with each other. This improves wireless network security. • Disable: It indicates that the wireless clients connected to the AP with the selected SSID can communicate with each other.
WMF	<p>It specifies whether to forward multicast packets through unicast tunnels. Generally, multicast packets are usually transmitted at the lowest rate, such as 1 Mbps, leading to poor transmission efficiency. WMF leverages the high auto-negotiated rate, reliable feedback mechanism, and other advantages of unicast packets to address multicast problems such as video playback stalls caused by packet loss and long delays over a wireless network.</p>
Max. Number of Clients	<p>It specifies the maximum number of wireless clients that can connect to the AP with the selected SSID.</p> <p>After this upper limit is reached, the AP rejects new connection requests from clients.</p>
SSID	<p>It enables you to change the selected SSID. Chinese characters are allowed in an SSID.</p>
Chinese SSID Encoding	<p>It specifies the encoding format of Chinese characters in an SSID. The default value is UTF8.</p> <p>If 2 or more SSIDs of the AP are enabled, you are recommended to set this parameter to UTF-8 for some SSIDs and to GB2312 for the other SSIDs, so that any wireless client can identify one or both SSIDs that contain Chinese characters.</p>
Security Mode	<p>It specifies the encryption type of the selected SSID. None indicates that any wireless client can connect to the AP using the selected SSID. This option is not recommended because it affects network security.</p> <p>The AP supports the WEP, WPA-PSK, WPA2-PSK, Mixed WPA/WPA2-PSK, WPA, and WPA2 security modes, which are elaborated in the following section.</p>

■ **None**

It allows any wireless client to connect to a wireless network. This option is not recommended because it affects network security.

■ **WEP**

The screenshot shows a configuration interface for WEP security. It includes a 'Security Mode' dropdown set to 'WEP', an 'Authentication Type' dropdown set to 'Open' (highlighted with a red border), and a 'Default Key' dropdown with options 'Open', 'Shared', and '802.1x'. Below these are four 'Key' fields (Key 1 to Key 4), each containing the value '12345' and an 'ASCII' dropdown menu.

Parameter description

Parameter	Description
	It specifies the encryption type for the WEP security mode of the AP. The options include Open , Shared , and 802.1x . The options share the same encryption process.
	<ul style="list-style-type: none">• Open It specifies that authentication is not required and data exchanged is encrypted using WEP. In this case, a wireless client can connect to the wireless network corresponding to the selected SSID without being authenticated, and the data exchanged between the client and the network is encrypted in WEP security mode.
Authentication Type	<ul style="list-style-type: none">• Shared It specifies that a shared key is used for authentication and data exchanged is encrypted using WEP. In this case, a wireless client must use a preset WEP key to connect to the wireless network corresponding to the selected SSID. The wireless client can be connected to the wireless network only if they use the same WEP key.• 802.1x It specifies that 802.1x authentication is required and data exchanged is encrypted using WEP. In this case, ports are enabled for user authentication when valid clients connect to the wireless network corresponding to the selected SSID, and disabled when invalid users connect to the wireless network.
Default Key	It specifies the default WEP key for the Open and Shared encryption types. For example, if Default Key is set to Key 2 , a wireless client can connect to the

Parameter	Description
	wireless network corresponding to the selected SSID only with the password specified by Key 2 .
ASCII	It indicates that a key selected for the Open or Shared authentication type contains hexadecimal characters. 5 or 13 ASCII characters are allowed in the key.
Hex	It indicates that a key selected for the Open or Shared authentication type contains hexadecimal characters. 10 or 26 hexadecimal characters (range: 0-9, a-f, and A-F) are allowed in the key.
RADIUS Server IP	
RADIUS Port	These parameters are dedicated to the 802.1x authentication type.
RADIUS Password	It specifies the IP address/port number/shared key of the RADIUS server for authentication.

■ WPA-PSK, WPA2-PSK, and Mixed WPA/WPA2-PSK

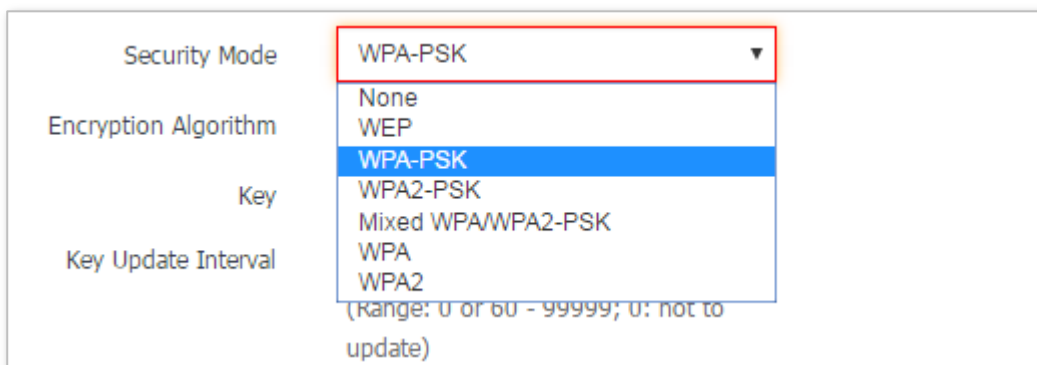

Parameter description

Parameter	Description
Security Mode	It indicates the personal or pre-shared key security mode, including WPA-PSK, WPA2-PSK, and Mixed WPA/WPA2-PSK. <ul style="list-style-type: none"> • WPA-PSK: It indicates that the wireless network corresponding to the selected SSID is encrypted using WPA-PSK. • WPA2-PSK: It indicates that the wireless network corresponding to the selected SSID is encrypted using WPA2-PSK. • Mixed WPA/WPA2-PSK: It indicates that wireless clients can connect to the wireless network corresponding to the selected SSID using either WPA-PSK or WPA2-PSK.
Encryption Algorithm	It specifies the encryption algorithm corresponding to the selected security mode. If Security Mode is set to WPA-PSK , this parameter has the AES and TKIP values. If Security Mode is set to WPA2-PSK or Mixed WPA/WPA2-PSK , this parameter has the AES , TKIP , and TKIP&AES values. <ul style="list-style-type: none"> • AES: It indicates the Advanced Encryption Standard.

Parameter	Description
	<ul style="list-style-type: none"> • TKIP: It indicates the Temporal Key Integrity Protocol. If TKIP is used, the maximum wireless throughput of the AP is limited to 54 Mbps. • TKIP&AES: It indicates that both TKIP and AES encryption algorithms are supported. Wireless clients can connect to the wireless network corresponding to the selected SSID using TKIP or AES.
Key	It specifies a pre-shared WPA key. A WPA key can contain 8 to 63 ASCII characters or 8 to 64 hexadecimal characters.
Key Update Interval	It specifies the automatic update interval of a WPA key for data encryption. A shorter interval results in higher data security. The value 0 indicates that a WAP key is not updated.

■ WPA and WPA2

The screenshot shows a configuration window with the following fields:

- Security Mode**: A dropdown menu with options: None, WEP, WPA-PSK, WPA2-PSK, Mixed WPA/WPA2-PSK, **WPA** (selected), and WPA2.
- RADIUS Server IP**: A text input field.
- RADIUS Port**: A text input field with a range of 1025 - 65535 and a default of 1812.
- RADIUS Password**: A text input field.
- Encryption Algorithm**: Radio buttons for **AES** (selected), TKIP, and TKIP&AES.
- Key Update Interval**: A text input field with the value 0, and a range of 0 or 60 - 99999; 0: not to update.

Parameter description

Parameter	Description
Security Mode	<p>The WPA and WPA2 options are available for network protection with a RADIUS server.</p> <ul style="list-style-type: none"> • WPA: It indicates that the wireless network corresponding to the selected SSID is encrypted using WPA. • WPA: It indicates that the wireless network corresponding to the selected SSID is encrypted using WPA.
RADIUS Server IP	It specifies the IP address of the RADIUS server for client authentication.
RADIUS Port	It specifies the port number of the RADIUS server for client authentication.
RADIUS Password	It specifies the shared password of the RADIUS server.
Encryption Algorithm	<p>It specifies the encryption algorithm corresponding to the selected security mode. The available options include AES, TKIP, and TKIP&AES.</p> <ul style="list-style-type: none"> • AES: It indicates the Advanced Encryption Standard. • TKIP: It indicates the Temporal Key Integrity Protocol.

Parameter	Description
	<ul style="list-style-type: none"> • TKIP&AES: It indicates that both TKIP and AES encryption algorithms are supported. Wireless clients can connect to the wireless network corresponding to the selected SSID using TKIP or AES.
Key Update Interval	<p>It specifies the automatic update interval of a WPA key for data encryption. A shorter interval results in higher data security.</p> <p>The value 0 indicates that a WAP key is not updated.</p>

7.1.3 Examples of configuring SSID setup

Setting up a non-encrypted wireless network

Networking requirement

In a hotel lounge, guests can connect to the wireless network without a password and access the internet through the wireless network.

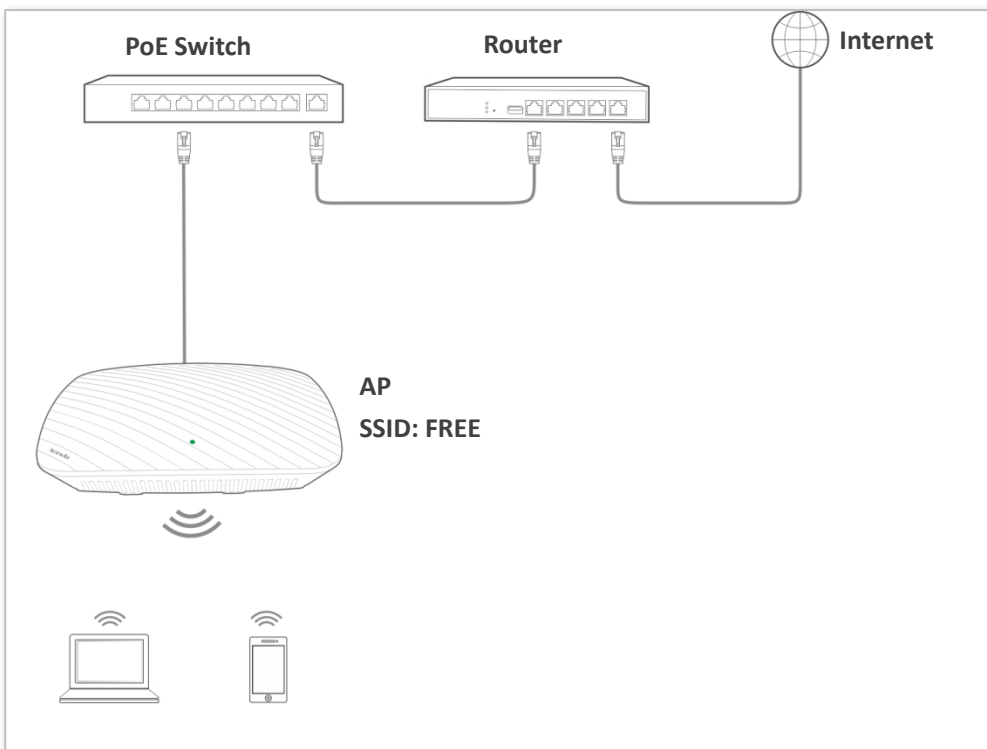

Configuration procedure:

Assume that the second SSID of the AP, the WPA2-PSK security mode, and AES encryption algorithm are used.

- Step 1** Choose **Wireless > Basic**.
- Step 2** Select the second SSID from the SSID drop-down list box.
- Step 3** Select the **Enable** check box.
- Step 4** Change the value of the SSID text box to **FREE**.
- Step 5** Set **Security Mode** to **None**.

Step 6 Click **Save**.

The screenshot shows a configuration window titled "Basic" with the following settings:

- * SSID: FREE (dropdown menu)
- * Enable: (checkbox)
- Broadcast SSID: Enable (dropdown menu)
- Isolate Client: Disable Enable (radio buttons)
- WMF: Disable Enable (radio buttons)
- Max. Number of Clients: 48 (text input) (Range: 1 - 64)
- * SSID: FREE (text input)
- Chinese SSID Encoding: UTF-8 (dropdown menu)
- * Security Mode: None (dropdown menu)

On the right side of the window, there are three buttons: "Save", "Restore", and "Help".

--End

Verification

Wireless devices can connect to the **FREE** wireless network without a password.

Setting up a wireless network encrypted using WPA/WPA2-PSK

Network requirement

A company wireless network with a certain level of security must be set up through a simple procedure. In this case, WPA/WPA2 pre-shared key mode is recommended.

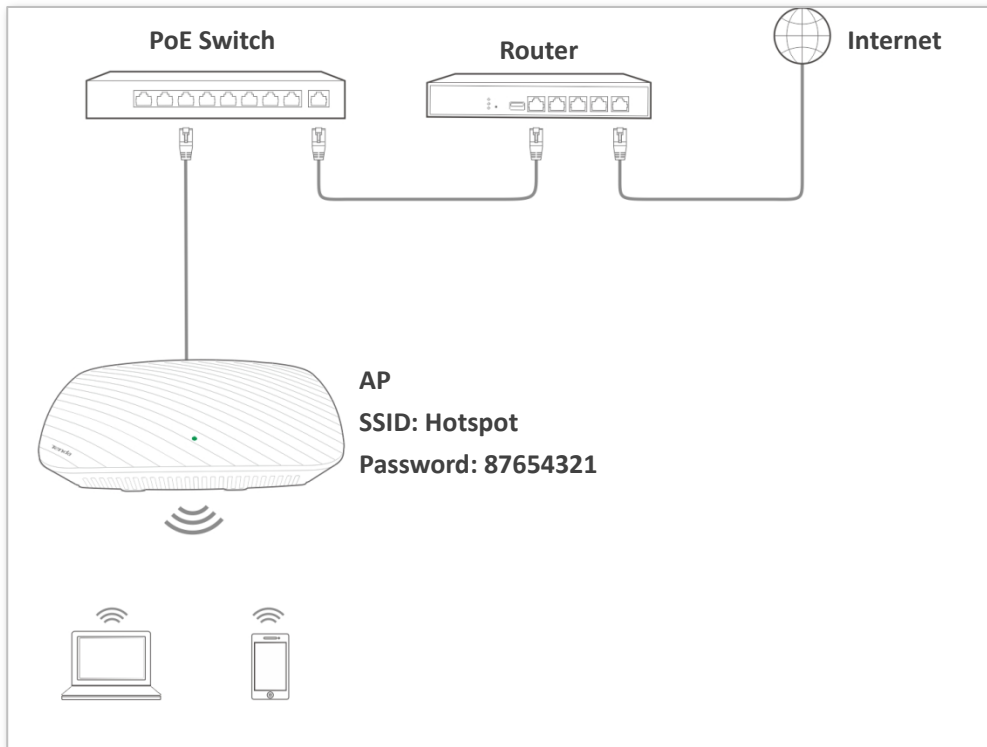

Configuration procedure:

Assume that the second SSID of the AP, the WPA2-PSK security mode, and AES encryption algorithm are used.

- Step 1** Choose **Wireless > Basic**.
- Step 2** Select the second SSID from the SSID drop-down list box.
- Step 3** Select the **Enable** check box.
- Step 4** Change the value of the **SSID** text box to **Hotspot**.
- Step 5** Set **Security Mode** to **WPA2-PSK** and **Encryption Algorithm** to **AES**.
- Step 6** Set **Key** to **87654321**.
- Step 7** Click **Save**.

Basic

* SSID	Hotspot	Save
* Enable	<input checked="" type="checkbox"/>	Restore
Broadcast SSID	Enable	Help
Isolate Client	<input checked="" type="radio"/> Disable <input type="radio"/> Enable	
WMF	<input checked="" type="radio"/> Disable <input type="radio"/> Enable	
Max. Number of Clients	48 (Range: 1 - 64)	
* SSID	Hotspot	
Chinese SSID Encoding	UTF-8	
* Security Mode	WPA2-PSK	
* Encryption Algorithm	<input checked="" type="radio"/> AES <input type="radio"/> TKIP <input type="radio"/> TKIP&AES	
* Key	*****	
Key Update Interval	0 (Range: 0 or 60 - 99999; 0: not to update)	

--End

Verification

Wireless devices can connect to the **Hotspot** wireless network with the password **87654321**.

Setting up a wireless network encrypted using WPA or WPA2

Network requirement

A highly secure wireless network is required and a RADIUS server is available. In this case, WPA or WPA2 mode is recommended.

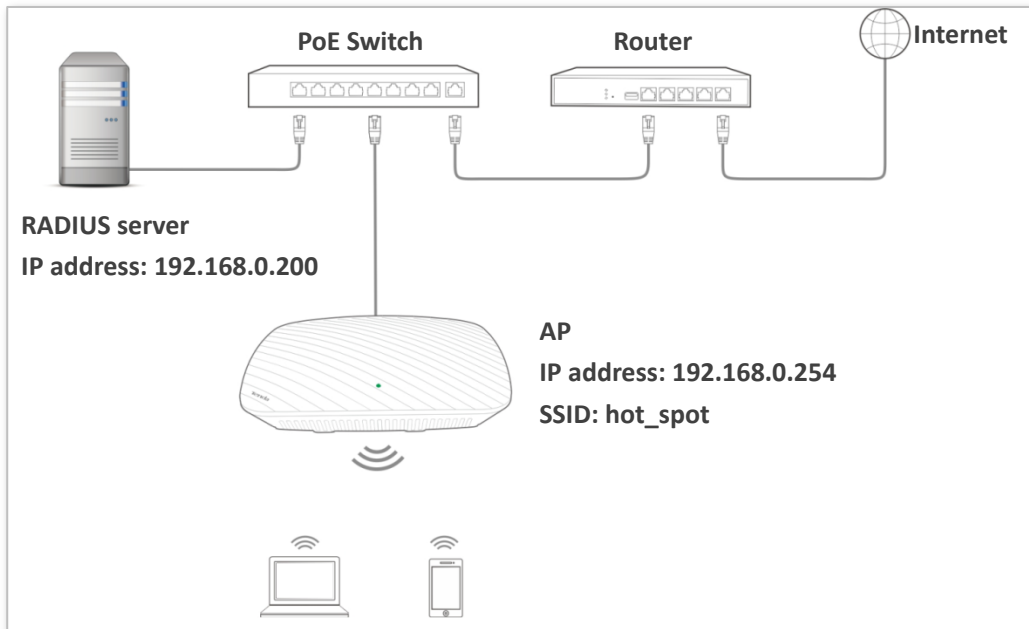

Configuration procedure:

■ Configuring the AP

Assume that the IP address of the RADIUS server is 192.168.0.200, the RADIUS password is 12345678, and the port number for authentication is 1812.

Assume that the second SSID of the AP is used.

- Step 1** Choose **Wireless > Basic**.
- Step 2** Select the second SSID from the SSID drop-down list box.
- Step 3** Select the **Enable** check box.
- Step 4** Change the value of the **SSID** text box to **hot_spot**.
- Step 5** Set **Security Mode** to **WPA2**.
- Step 6** Set **RADIUS Server IP**, **RADIUS Port**, and **RADIUS Password** to **192.168.0.200**, **1812**, and **12345678** respectively.
- Step 7** Set **Encryption Algorithm** to **AES**.
- Step 8** Click **Save**.

Basic

* SSID: hot_spot

* Enable:

Broadcast SSID: Enable

Isolate Client: Disable Enable

WMF: Disable Enable

Max. Number of Clients: 48 (Range: 1 - 64)

* SSID: hot_spot

Chinese SSID Encoding: UTF-8

* Security Mode: WPA2

* RADIUS Server IP: 192.168.0.200

* RADIUS Port: 1812 (Range: 1025 - 65535; Default: 1812)

* RADIUS Password:

* Encryption Algorithm: AES TKIP TKIP&AES

Key Update Interval: 0

Save

Restore

Help

--End

■ **Configuring the RADIUS server**



Windows 2003 is used as an example to describe how to configure the RADIUS server.

Step 1 Configure a RADIUS client.

In the **Computer Management** dialog box, double-click **Internet Authentication Service**, right-click **RADIUS Clients**, and choose **New RADIUS Client**.

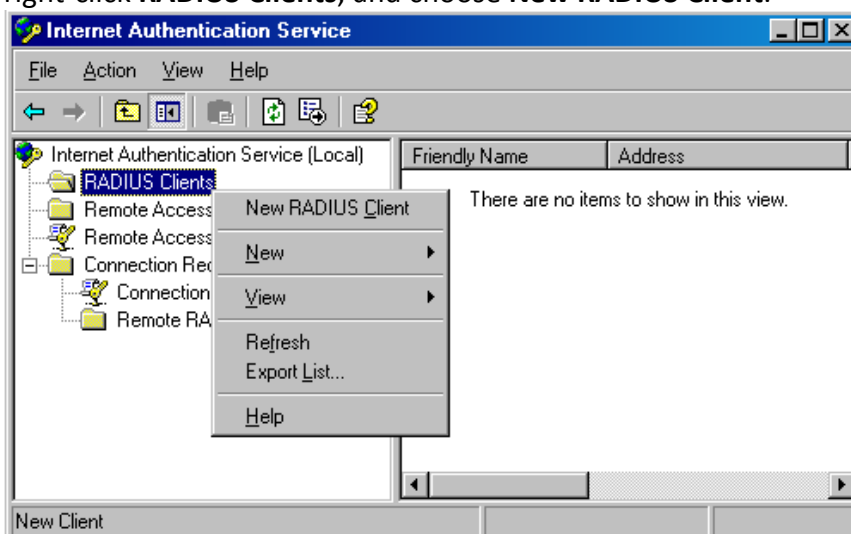

Enter a RADIUS client name (which can be the name of the AP) and the IP address of the AP, and click **Next**.

The screenshot shows the 'New RADIUS Client' dialog box with the 'Name and Address' tab selected. The dialog has a title bar with a close button. Below the title bar is a section header 'Name and Address' followed by a horizontal line. The main area contains the instruction 'Type a friendly name and either an IP Address or DNS name for the client.' There are two text input fields: 'Friendly name:' containing 'root' and 'Client address (IP or DNS):' containing '192.168.0.254'. A 'Verify...' button is to the right of the second field. An orange arrow points from the text 'IP address of your AP' below to the 'Client address' field. At the bottom are three buttons: '< Back', 'Next >', and 'Cancel'.

Enter **12345678** in the **Shared secret** and **Confirm shared secret** text boxes, and click **Finish**.

The screenshot shows the 'New RADIUS Client' dialog box with the 'Additional Information' tab selected. The dialog has a title bar with a close button. Below the title bar is a section header 'Additional Information' followed by a horizontal line. The main area contains the instruction 'If you are using remote access policies based on the client vendor attribute, specify the vendor of the RADIUS client.' There are three fields: 'Client-Vendor:' with a dropdown menu showing 'RADIUS Standard', 'Shared secret:' with a masked text box containing 'xxxxxxxx', and 'Confirm shared secret:' with a masked text box containing 'xxxxxxxx'. A dashed orange box encloses the 'Client-Vendor', 'Shared secret', and 'Confirm shared secret' fields. An orange arrow points from the text 'Password same as that specified by RADIUS Password on the AP' below to the 'Shared secret' field. Below the fields is a checkbox labeled 'Request must contain the Message Authenticator attribute'. At the bottom are three buttons: '< Back', 'Finish', and 'Cancel'.

Step 2 Configure a remote access policy.

Right-click **Remote Access Policies** and choose **New Remote Access Policy**.

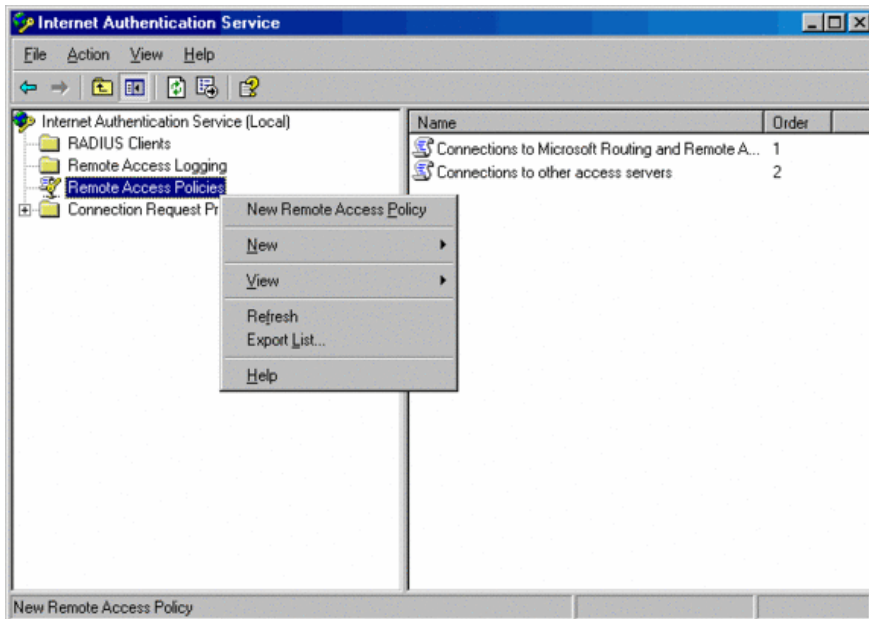

In the **New Remote Access Policy Wizard** dialog box that appears, click **Next**.

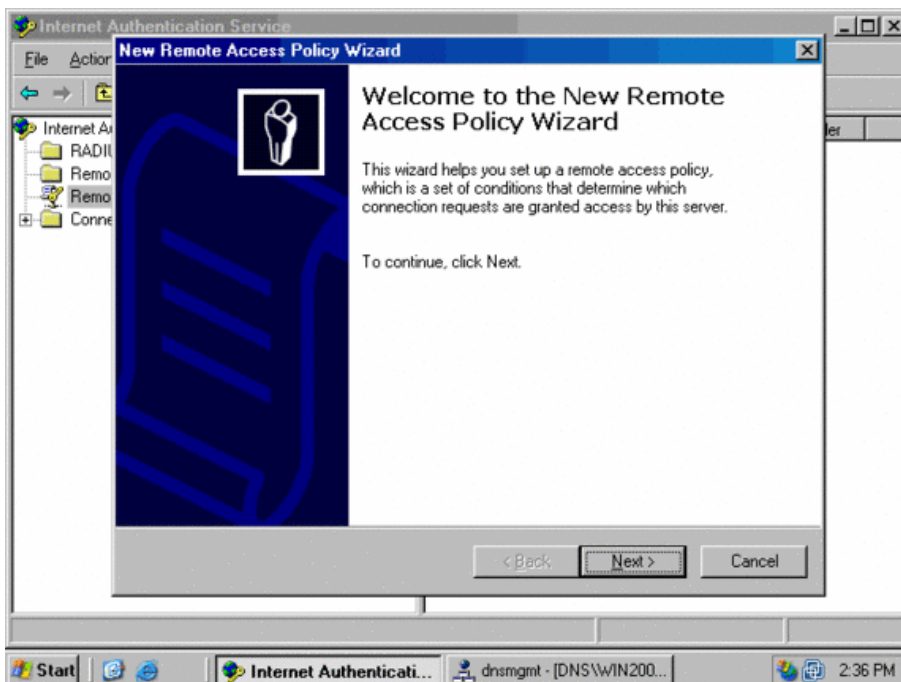

Enter a policy name and click **Next**.

The screenshot shows the 'New Remote Access Policy Wizard' dialog box. The title bar reads 'New Remote Access Policy Wizard'. The main heading is 'Policy Configuration Method' with a sub-heading 'The wizard can create a typical policy, or you can create a custom policy.' Below this, the question 'How do you want to set up this policy?' is followed by two radio button options: 'Use the wizard to set up a typical policy for a common scenario' (selected) and 'Set up a custom policy'. A text prompt asks to 'Type a name that describes this policy.' Below this is a text input field containing 'root', which is highlighted with a red dashed border. An example text 'Example: Authenticate all VPN connections.' is shown below the input field. At the bottom, there are three buttons: '< Back', 'Next >' (highlighted with a red dashed border), and 'Cancel'.

Select **Ethernet** and click **Next**.

The screenshot shows the 'New Remote Access Policy Wizard' dialog box. The title bar reads 'New Remote Access Policy Wizard'. The main heading is 'Access Method' with a sub-heading 'Policy conditions are based on the method used to gain access to the network.' Below this, the question 'Select the method of access for which you want to create a policy.' is followed by four radio button options: 'VPN' (with a sub-description), 'Dial-up' (with a sub-description), 'Wireless' (with a sub-description), and 'Ethernet' (selected and highlighted with a red dashed border, with a sub-description). At the bottom, there are three buttons: '< Back', 'Next >' (highlighted with a red dashed border), and 'Cancel'.

Select **Group** and click **Add**.



Enter **802.1x** in the **Enter the object names to select** text box, click **Check Names**, and click **OK**.

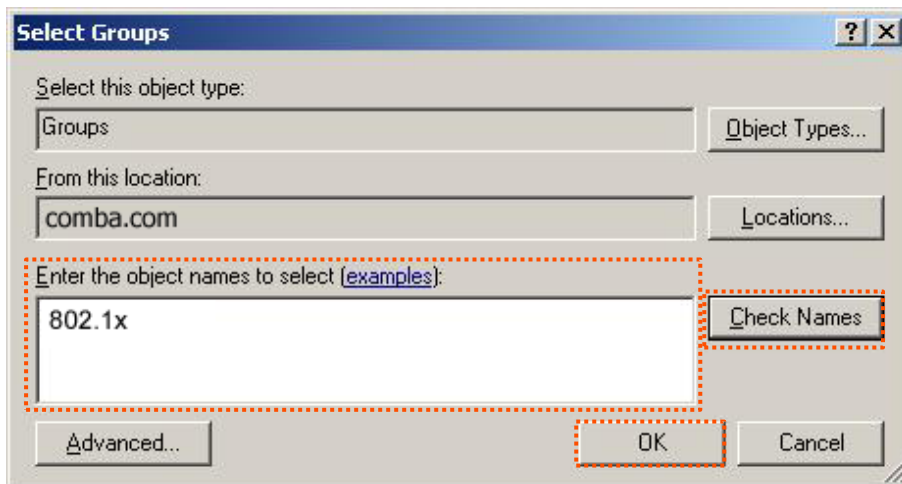

Select **Protected EAP (PEAP)** and click **Next**.

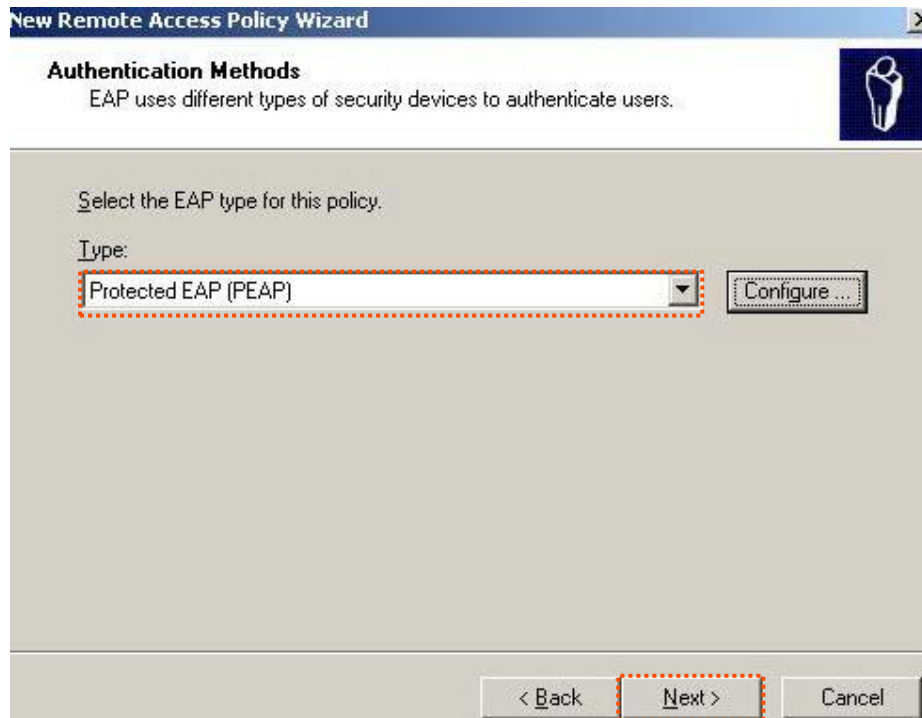

Click **Finish**. The remote access policy is created.

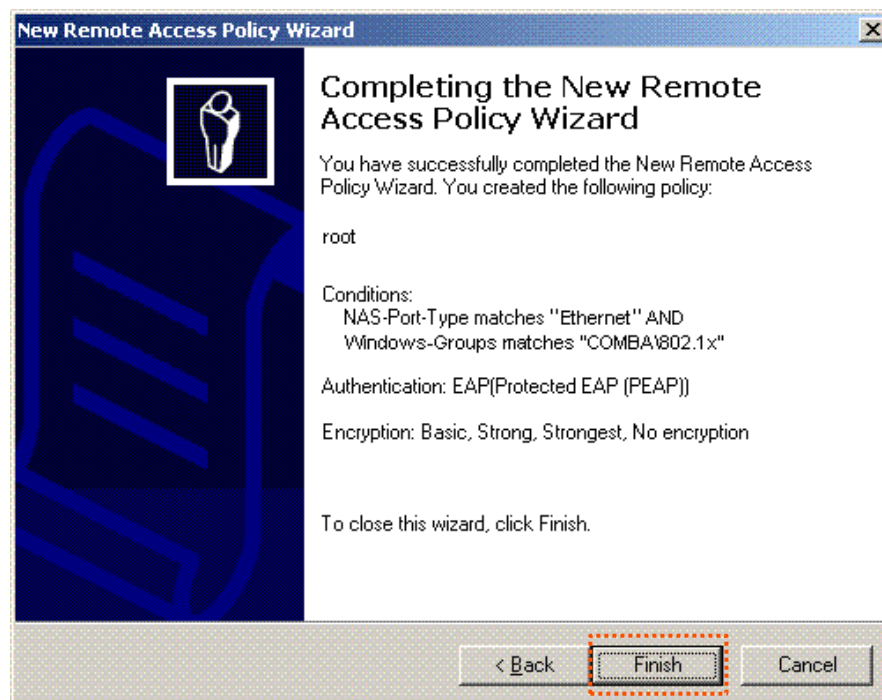

Right-click **root** and choose **Properties**. Select **Grant remote access permission**, select **NAS-Port-Type matches "Ethernet" AND**, and click **Edit**.

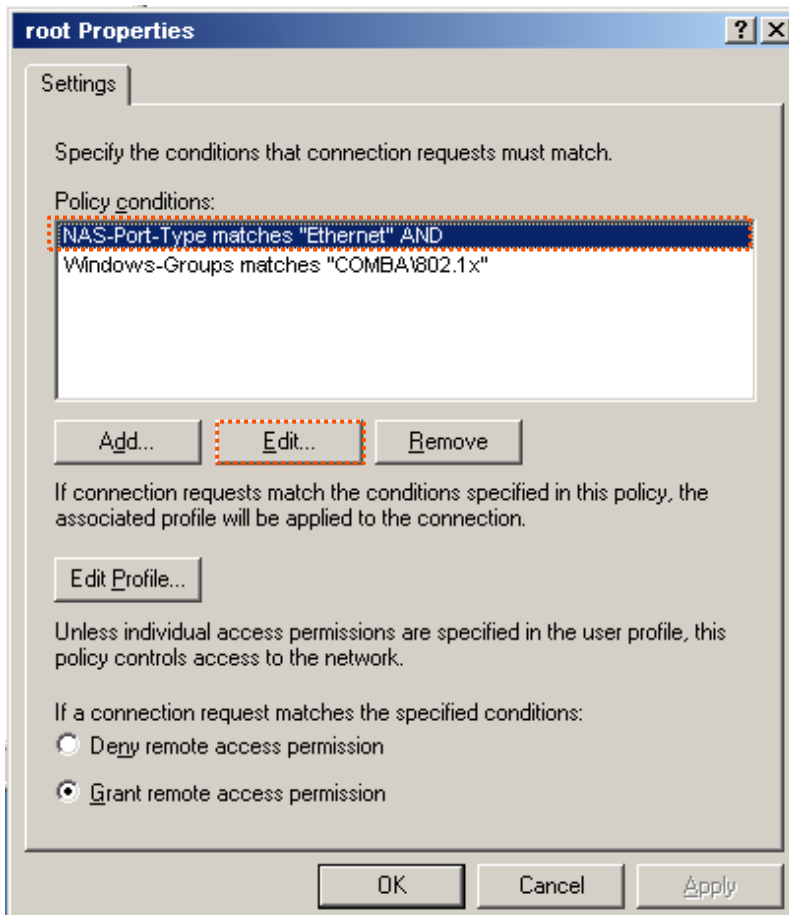

Select **Wireless – Other**, click **Add**, and click **OK**.

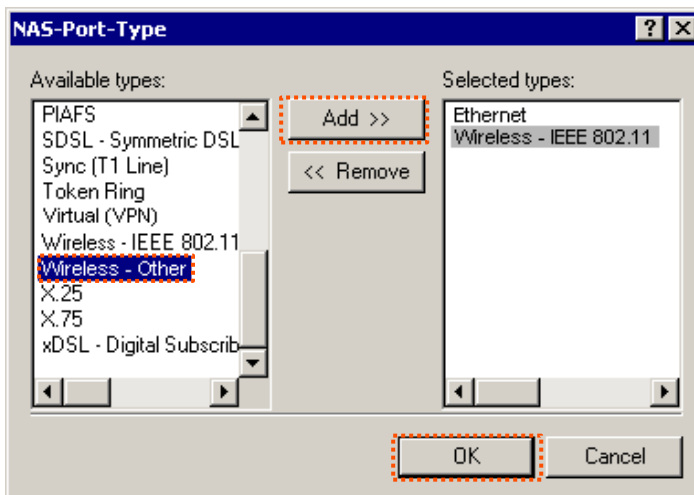

Click **Edit Profile**, click the **Authentication** tab, configure settings as shown in the following figure, and click **OK**.

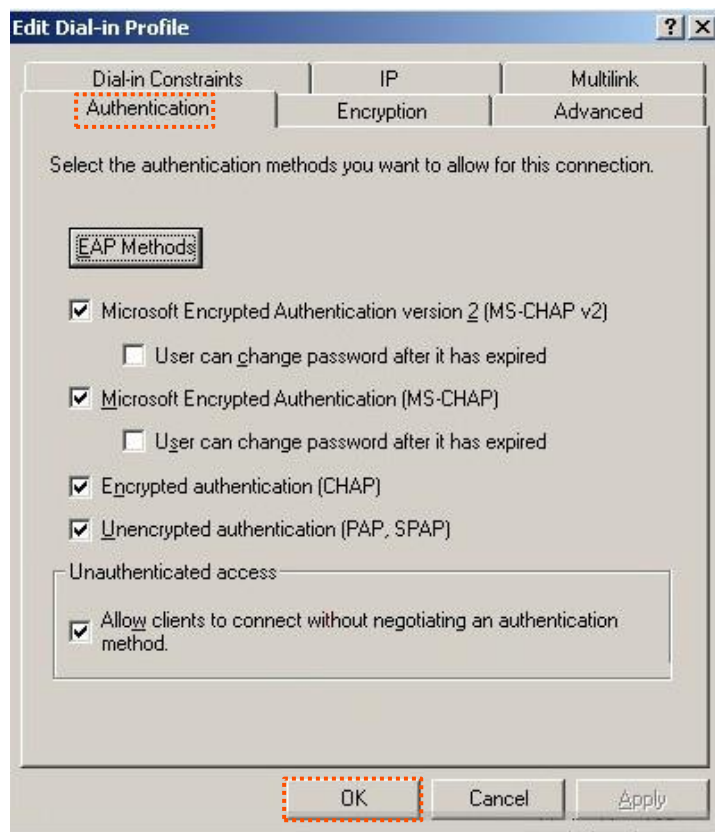

When a message appears, click **No**.

Step 3 Configure user information. Create a user and add the user to group **802.1x**.

--End

■ Configure your wireless device



Windows 7 is taken as an example to describe the procedure.

Step 1 Choose **Start > Control Panel**, and click **Network and Internet > Network and Sharing Center > Manage wireless networks**.

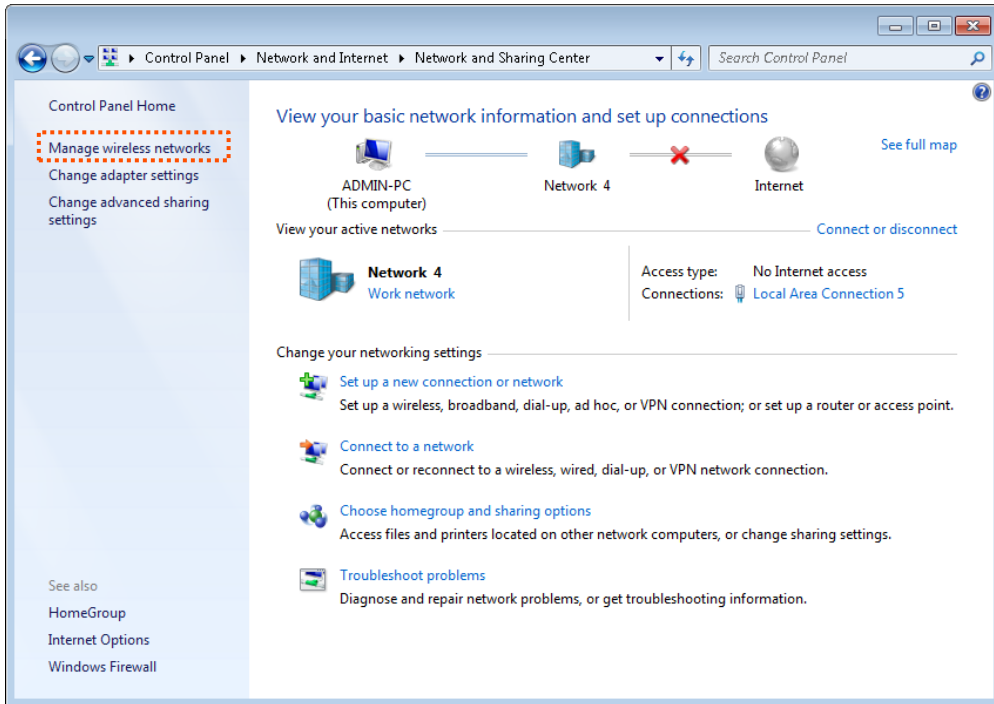

Step 2 Click **Add**.

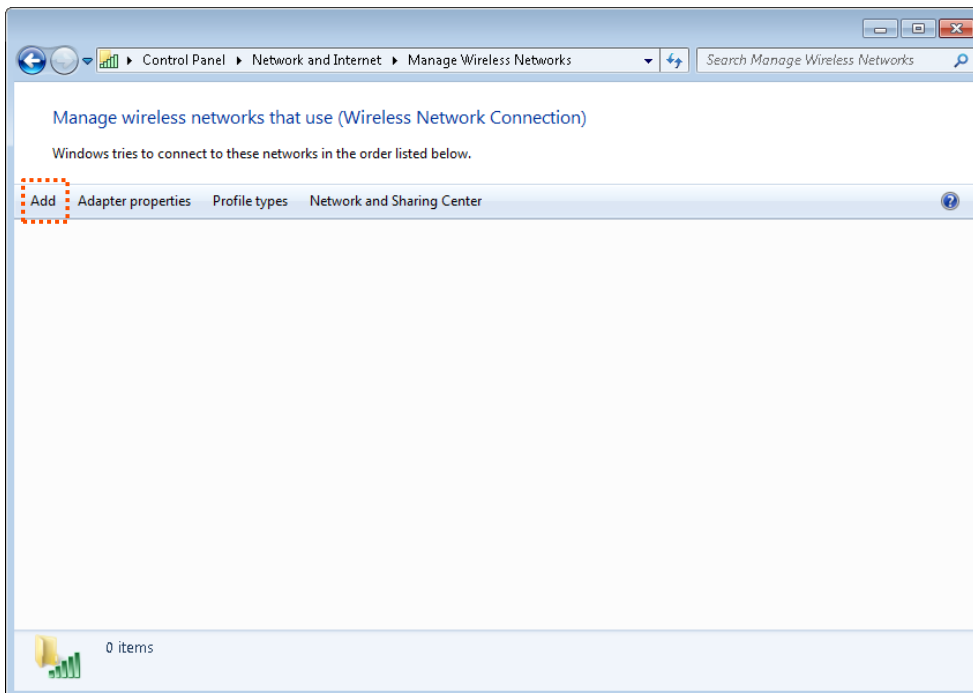

Step 3 Click **Manually create a network profile**.

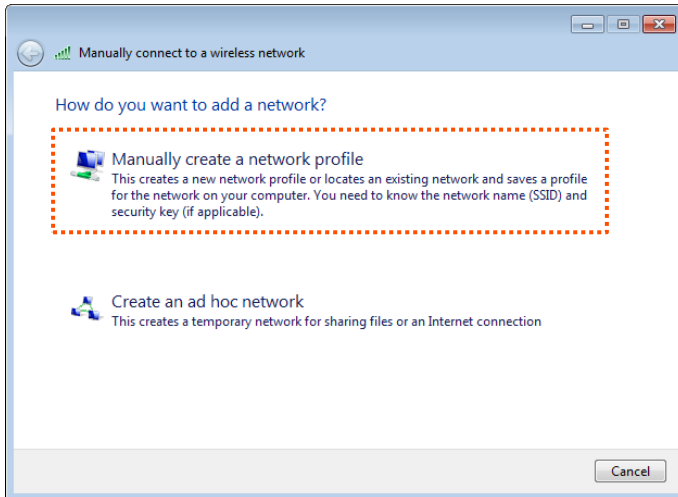

Step 4 Enter wireless network information, select **Connect even if the network is not broadcasting**, and click **Next**.

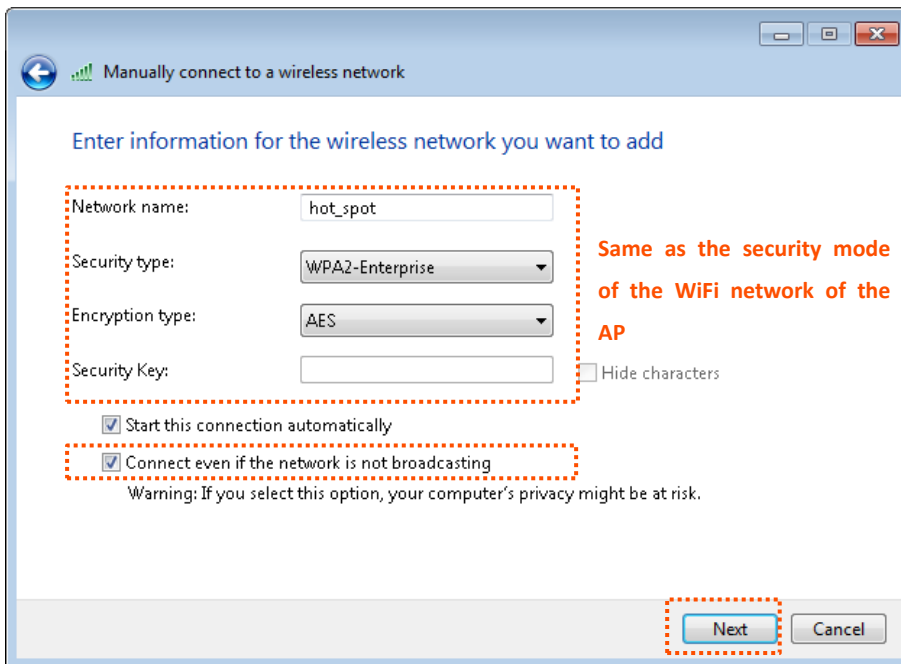

Step 5 Click **Change connection settings**.

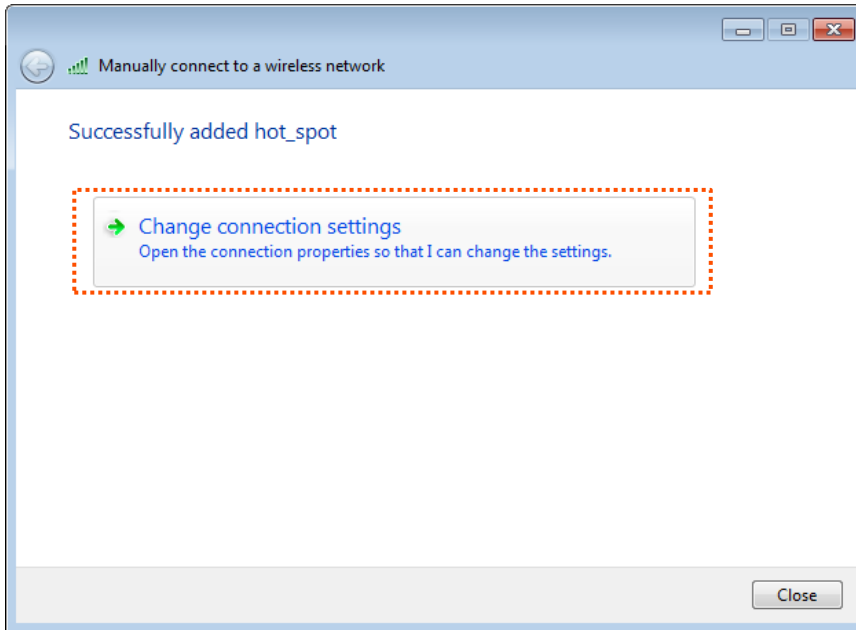

Step 6 Click the **Security** tab, select **Microsoft: Protected EAP (PEAP)**, and click **Settings**.

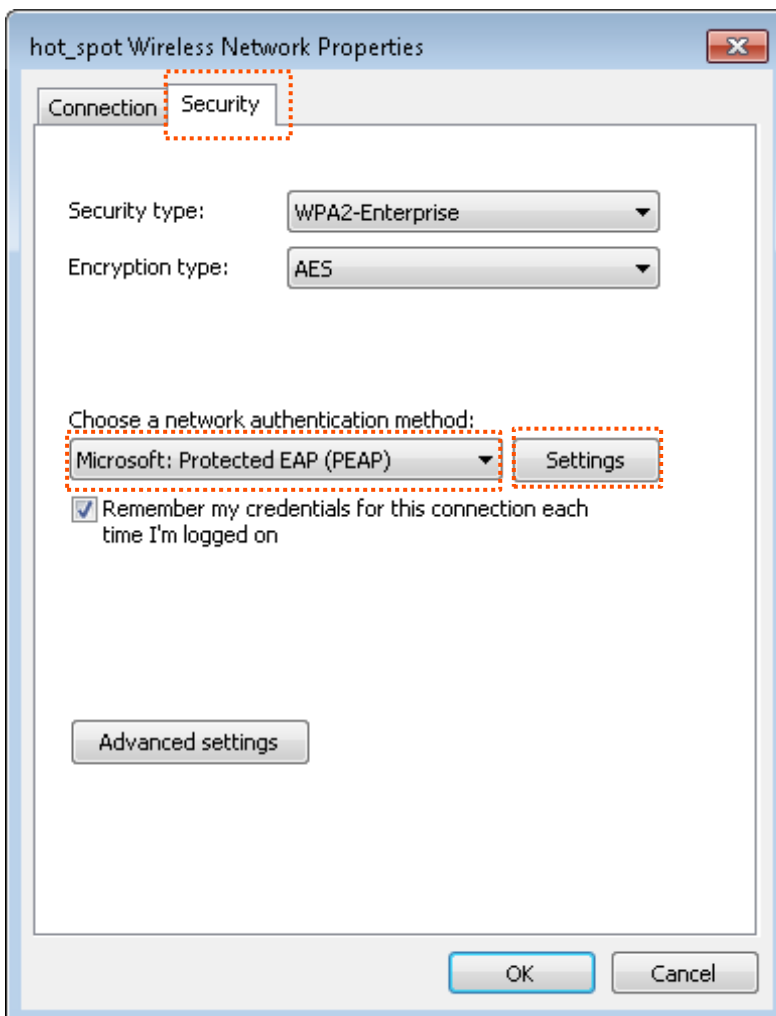

Step 7 Deselect **Validate server certificate** and click **Configure**.

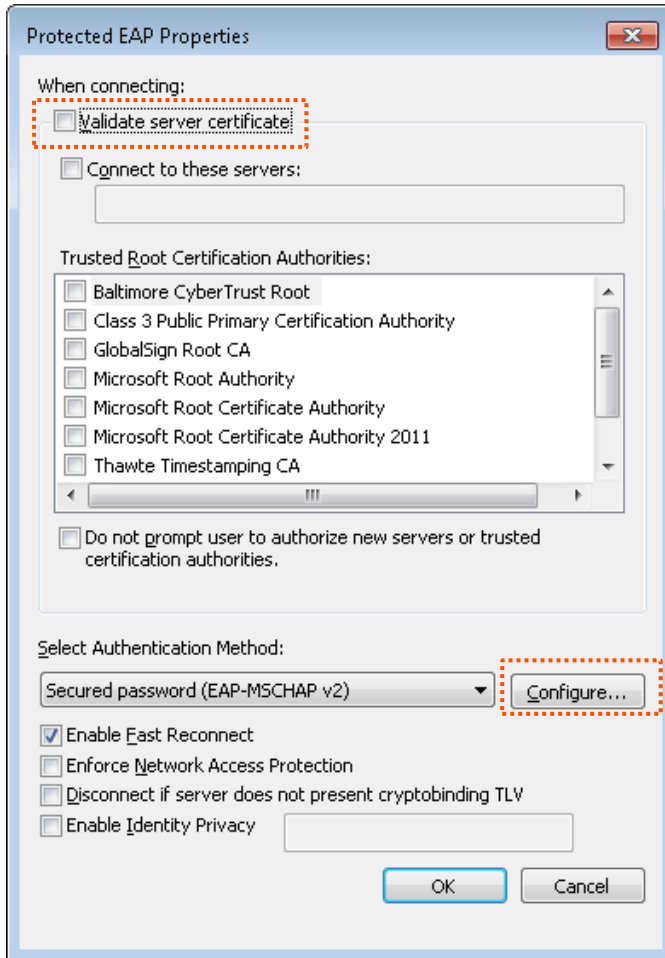

Step 8 Deselect **Automatically use my Windows logon name and password (and domain if any)** and click **OK**.

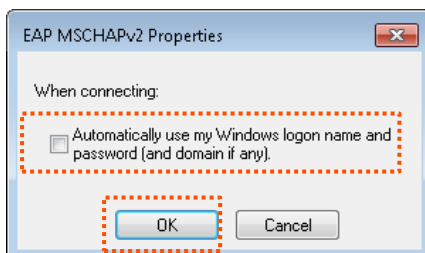

Step 9 Click **Advanced settings**.

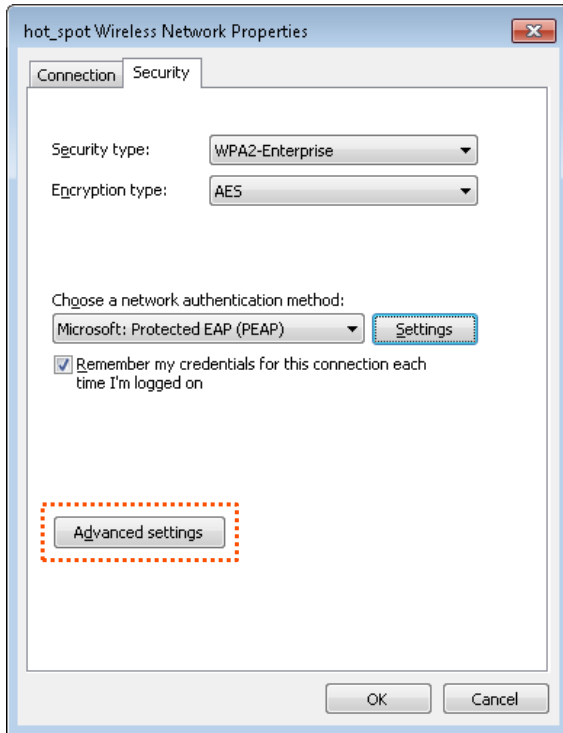

Step 10 Select **User or computer authentication** and click **OK**.

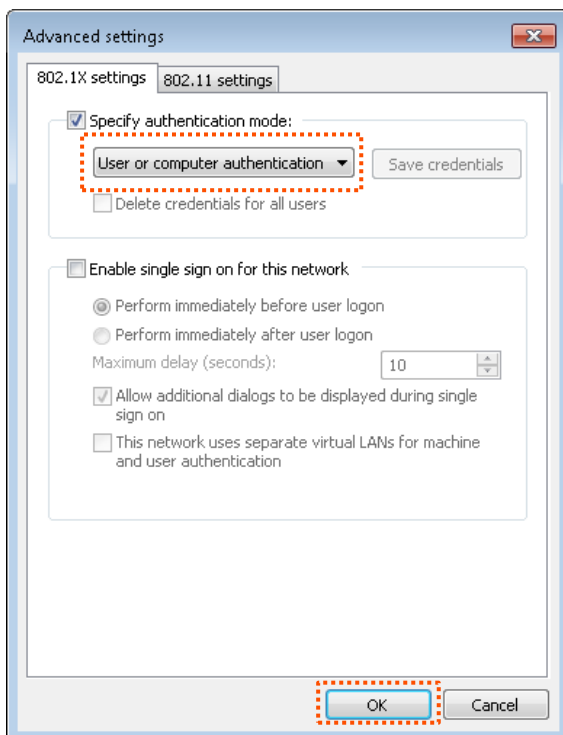

Step 11 Click **Close**.

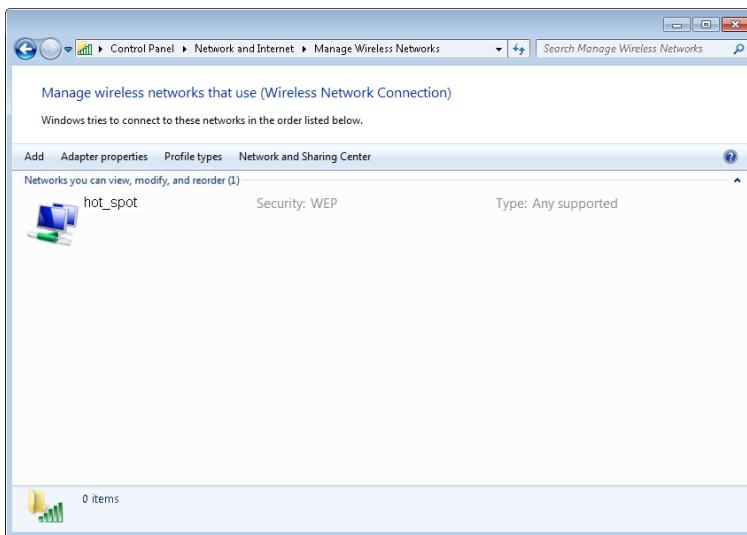
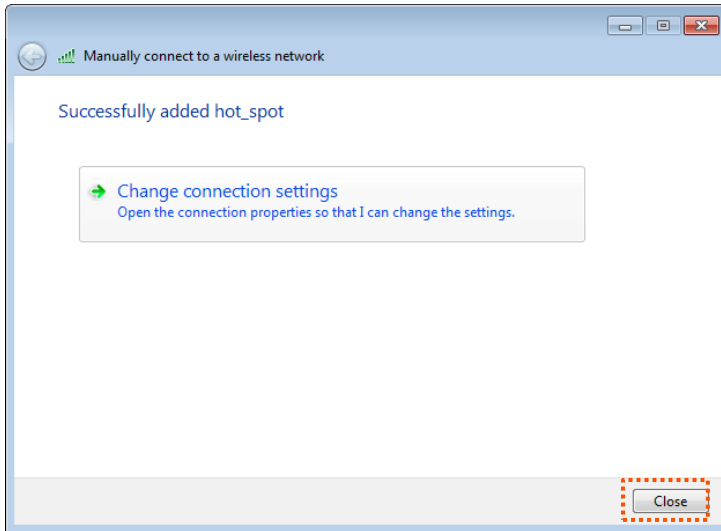

Step 12 Click the network icon in the lower-right corner of the desktop and choose the wireless network of the AP such as **hot_spot** in this example.

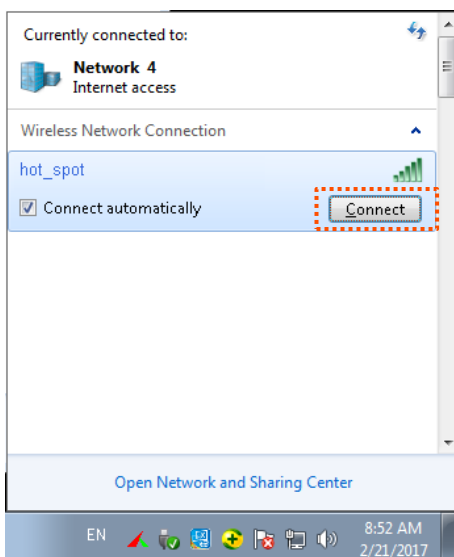

Step 13 In the **Windows Security** dialog box that appears, enter the [user name and password](#) set on the RADIUS server and click **OK**.

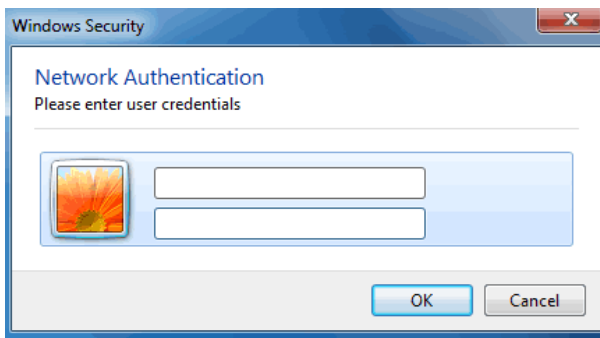

--End

Verification

Wireless devices can connect to the wireless network **hot_spot**.

7.2 RF Settings

7.2.1 Overview

The RF module is used to set radio parameters of the AP. The following briefly describes the SSID isolation function.

Isolate SSID

This function isolates the wireless clients connected to different wireless networks of the AP. For example, if user 1 connects to the wireless network corresponding to SSID1, whereas user 2 connects to the wireless network corresponding to SSID2, the two users cannot communicate with each other after SSID isolation is implemented.

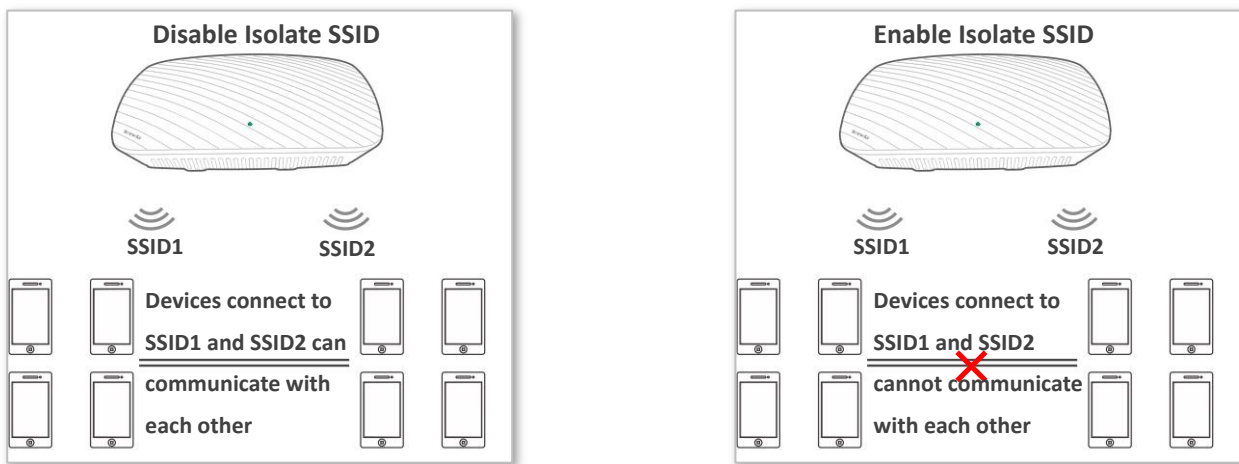

7.2.2 Changing the RF settings

Step 1 Choose **Wireless > RF**.

Step 2 Change the parameters as required. Generally, you only need to change the **Enable RF**, **Channel**, **Lock Channel**, **Isolate SSID** and **Client Timeout Interval** settings.

Step 3 Click **Save**.

The screenshot shows a configuration window titled "RF" with the following settings:

- Enable RF:
- Country/Region: China
- Network Mode: 11b/g/n
- Channel: Auto
- Channel Bandwidth: 20MHz 40MHz 20/40MHz
- Extension Channel: Auto
- Lock Channel:
- Isolate SSID: Disable Enable
- APSD: Enable Disable
- Client Timeout Interval: 5 minutes

Buttons on the right: Save, Restore, Help.

--End

Parameter description

Parameter	Description
Enable RF	It specifies whether to enable the RF function of the AP.
Country	It specifies the country or region where the AP is used. This parameter helps comply with channel regulations of the country or region.
Network Mode	<p>It specifies the wireless network mode of the AP.</p> <p>Available options include 11b/g, 11b, 11g, and 11b/g/n. This parameter can be set if Lock Channel is not selected.</p> <ul style="list-style-type: none"> • 11b: It indicates that only clients working in the 11b network mode can connect to the AP. • 11g: It indicates that only clients working in the 11g network mode can connect to the AP. • 11b/g: It indicates that only clients working in the 11b or 11g network mode can connect to the AP. • 11b/g/n: It indicates that clients working in the 11b, 11g, or 11n network mode can connect to the AP.
Channel	It specifies the operating channel of the AP. This parameter can be set if Channel Lockout is not selected.
Channel Bandwidth	<p>It specifies the bandwidth of the operating channel of the AP. This parameter can be set if Channel Lockout is not selected.</p> <ul style="list-style-type: none"> • 20MHz: It indicates that the AP only uses 20 MHz channel bandwidth. • 40MHz: It indicates that the AP only uses 40 MHz channel bandwidth. • 20/40MHz: It indicates that the AP automatically adjusts its channel bandwidth to 20

Parameter	Description
	MHz or 40 MHz according to the ambient environment. This option is effective only for 802.11b/g/n mixed network mode.
Extension Channel	It specifies an additional channel used to increase the channel bandwidth if the AP works in the 802.11b/g/n mixed network mode and the channel bandwidth option 40MHz or 20/40MHz is selected.
Lock Channel	It is used to lock the selected channel. After a channel is locked, parameters of the channel cannot be changed, including Country , Network Mode , Channel , Channel Bandwidth , and Extension Channel .
Isolate SSID	It specifies whether to isolate the wireless clients connected to the AP with different SSIDs. <ul style="list-style-type: none"> • Disable: It indicates that the wireless clients connected to the AP with different SSIDs can communicate with each other. • Enable: It indicates that the wireless clients connected to the AP with different SSID cannot communicate with each other. This improves wireless network security.
APSD	It specifies whether to enable the Automatic Power Save Delivery (APSD) function. It helps reduce power consumption of the AP. By default, it is disabled.
Client Timeout Interval	It is used to set the timeout interval of clients. After a wireless client connects to the AP, the AP disconnects from the wireless client if no data is exchanged between them within the interval.

7.3 Channel Scan

7.3.1 Overview

This function enables you to know wireless networks information nearby, including SSID, MAC address, channel and wireless signal strength.

7.3.2 Checking the usage of channels

Step 1 Choose **Wireless > Channel Scan**.

Step 2 Click **Scan**.



--End

Wait for a moment. The following table shows the scanning result.

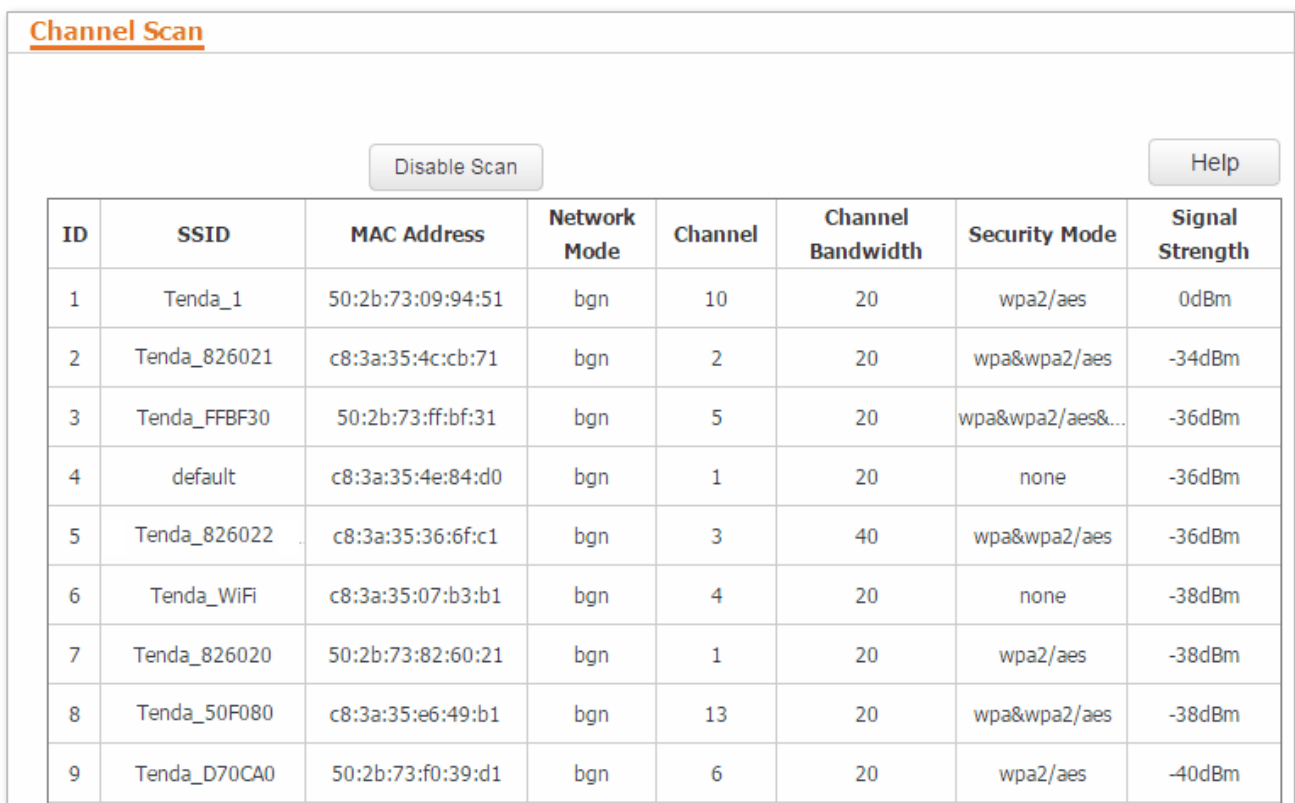

The screenshot shows the "Channel Scan" interface after a scan. At the top, there is a "Disable Scan" button on the left and a "Help" button on the right. Below these buttons is a table with 8 columns: ID, SSID, MAC Address, Network Mode, Channel, Channel Bandwidth, Security Mode, and Signal Strength. The table contains 9 rows of data.

ID	SSID	MAC Address	Network Mode	Channel	Channel Bandwidth	Security Mode	Signal Strength
1	Tenda_1	50:2b:73:09:94:51	bgn	10	20	wpa2/aes	0dBm
2	Tenda_826021	c8:3a:35:4c:cb:71	bgn	2	20	wpa&wpa2/aes	-34dBm
3	Tenda_FFBF30	50:2b:73:ff:bf:31	bgn	5	20	wpa&wpa2/aes&...	-36dBm
4	default	c8:3a:35:4e:84:d0	bgn	1	20	none	-36dBm
5	Tenda_826022	c8:3a:35:36:6f:c1	bgn	3	40	wpa&wpa2/aes	-36dBm
6	Tenda_WiFi	c8:3a:35:07:b3:b1	bgn	4	20	none	-38dBm
7	Tenda_826020	50:2b:73:82:60:21	bgn	1	20	wpa2/aes	-38dBm
8	Tenda_50F080	c8:3a:35:e6:49:b1	bgn	13	20	wpa&wpa2/aes	-38dBm
9	Tenda_D70CA0	50:2b:73:f0:39:d1	bgn	6	20	wpa2/aes	-40dBm

7.4 WMM Setup

7.4.1 Overview

802.11 networks offer wireless access services based on the Carrier Sense Multiple Access with Collision Avoidance (CSMA/CA) channel competition mechanism, which allows all wireless clients to fairly compete for channels. All the services implemented over wireless networks share the same channel competition parameters. Nevertheless, different services usually have different requirements for bandwidth, delay, and jitter. This requires wireless networks to offer accessibility based on the services implemented over the networks.

WMM is a wireless QoS protocol used to ensure that packets with high priorities are transmitted first. This ensures better voice and video service experience over wireless networks.

■ WMM involves the following terms:

- Enhanced Distributed Channel Access (EDCA): It is a channel competition mechanism to ensure that packets with higher priorities are assigned more bandwidth and transmitted earlier.
- Access Category (AC): AC: The WMM mechanism divides WLAN traffic by priority in descending order into the AC-VO (voice stream), AC-VI (video stream), AC-BE (best effort), and AC-BK (background) access categories. The access categories use queues with different priorities to send packets. The WMM mechanism ensures that packets in queues with higher priorities have more opportunities to access channels.

According to the 802.11 protocol family, all devices listen on a channel before using the channel to send data. If the channel stays idle for or longer than a specified period, the devices wait a random backoff period within the contention window. The device whose backoff period expires first can use the channel. The 802.11 protocol family applies the same backoff period and contention window to all devices across a network to ensure that the devices have the same channel contention opportunity.

■ EDCA Parameters

WMM changes the contention mechanism of 802.11 networks by dividing packets into four ACs, among which the ACs with higher priorities have more opportunities to access channels. The ACs help achieve different service levels.

WMM assigns each AC a set of EDCA parameters for channel contention, including:

- Arbitration Inter Frame Spacing Number (AIFSN): Different from the fixed distributed inter-frame spacing (DIFS) specified in the 802.11 protocol family, AIFSN varies across ACs. A greater AIFSN indicates a longer backoff period. See AIFS in the following figure.
- Contention window minimum (CW_{min}) and contention window maximum (CW_{max}) specify the average backoff period. The period increases along with these two values. See the backoff slots in the following figure.
- Transmission Opportunity (TXOP): It specifies the maximum channel use duration after successful channel contention. The duration increases along with this value. The value 0 indicates that a device can send only one packet through a channel after winning contention for the channel.

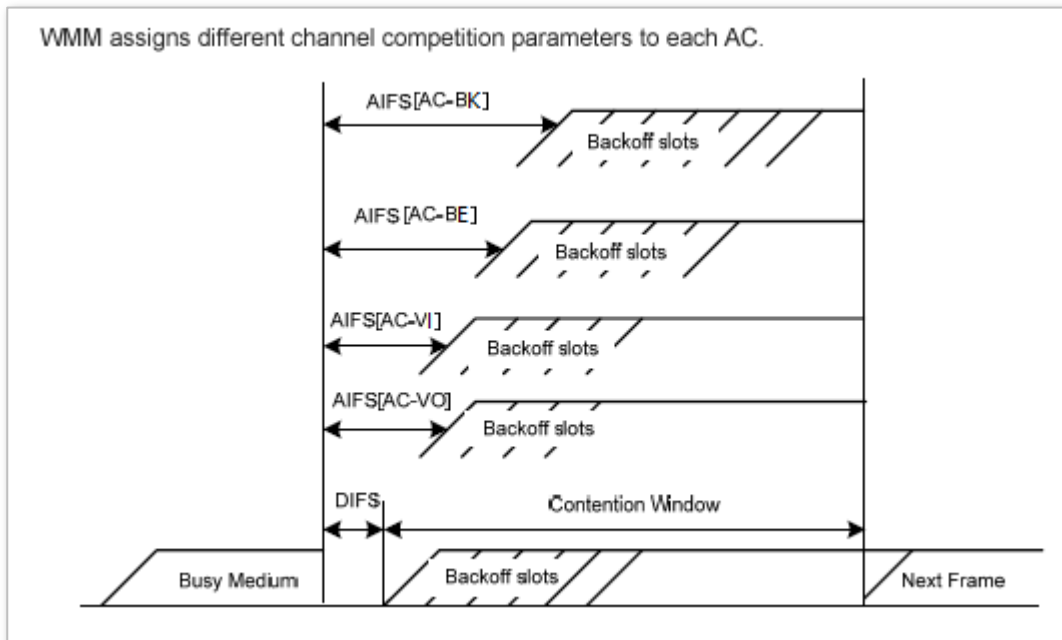

■ ACK Policies

WMM specifies the Normal ACK and No ACK policies.

- According to the No ACK policy, no ACK packet is used during wireless packet transmission to acknowledge packet reception. This policy is applicable to scenarios where interference is mild and can effectively improve transmission efficiency. In case of strong interference, lost packets are not sent again if this policy is adopted. This leads a higher packet loss rate and reduces the overall performance.
- According to the Normal ACK policy, each time a receiver receives a packet, it sends back an ACK packet to acknowledge packet reception.

7.4.2 Changing the WMM settings

By default, the WMM function of the AP is enabled and the **Optimized For Capacity** mode is adopted. Procedure for changing the WMM settings:

- Step 1** Choose **Wireless > WMM Setup**.
- Step 2** Set the **WMM** to **Enable**.
- Step 3** Select the required WMM optimization mode.
- Step 4** If you select **Custom**, set the WMM parameters as required.
- Step 5** Click **Save**.

2.4GHz WMM

WMM Disable Enable Save

WMM Optimization Mode Optimized For Throughput(Concurrent Users <=10) Restore

Optimized For Capacity(Concurrent Users >=10)

Custom Help

No ACK

EDCA AP Parameters

	CWmin	CWmax	AIFSN	TXOP Limit(usec)
AC_BE	<input type="text" value="7"/>	<input type="text" value="63"/>	<input type="text" value="1"/>	<input type="text" value="4096"/>
AC_BK	<input type="text" value="15"/>	<input type="text" value="1023"/>	<input type="text" value="7"/>	<input type="text" value="0"/>
AC_VI	<input type="text" value="7"/>	<input type="text" value="15"/>	<input type="text" value="1"/>	<input type="text" value="6016"/>
AC_VO	<input type="text" value="3"/>	<input type="text" value="7"/>	<input type="text" value="1"/>	<input type="text" value="3264"/>

EDCA STA Parameters

	CWmin	CWmax	AIFSN	TXOP Limit(usec)
AC_BE	<input type="text" value="31"/>	<input type="text" value="255"/>	<input type="text" value="2"/>	<input type="text" value="3200"/>
AC_BK	<input type="text" value="15"/>	<input type="text" value="1023"/>	<input type="text" value="7"/>	<input type="text" value="0"/>
AC_VI	<input type="text" value="7"/>	<input type="text" value="15"/>	<input type="text" value="2"/>	<input type="text" value="6016"/>
AC_VO	<input type="text" value="3"/>	<input type="text" value="7"/>	<input type="text" value="2"/>	<input type="text" value="3264"/>

Parameter description

Parameter	Description
WMM	<ul style="list-style-type: none"> • Enable: It is used to enable the WMM function. • Disable: It is used to disable the WMM function.
WMM Optimization Mode	<p>It specifies the WMM optimization modes supported by the AP:</p> <ul style="list-style-type: none"> • Optimized For Throughput(Concurrent Users <=10): If 10 or less clients are connected to the AP, you are recommended to select this mode to increase client throughput. • Optimized For Capacity(Concurrent Users >=10): If more than 10 clients are connected to the AP, you are recommended to select this mode to ensure client connectivity. • Custom: This mode enables you to set the WMM EDCA parameters for manual optimization.
No ACK	<ul style="list-style-type: none"> • If the check box is selected, the No ACK policy is adopted. • If the check box is deselected, the Normal ACK policy is adopted.

Parameter	Description
EDCA Parameters	For details, refer to section 7.5.1 Overview .

7.5 Advanced

7.5.1 Overview

This module is used to set the RF performance optimization parameters of the AP.

7.5.2 Changing the advanced settings



It is recommended that you change the settings only under the instruction of professional personnel, so as to prevent decreasing the wireless performance of the AP.

Step 1 Choose **Wireless > Advanced**.

Step 2 Change the parameters as required.

Step 3 Click **Save**.

Advanced

Beacon Interval	<input type="text" value="100"/>	ms (Range: 100 - 999; Default: 100)	<input type="button" value="Save"/>
Fragment Threshold	<input type="text" value="2346"/>	(Range: 256 - 2346; Default: 2346)	<input type="button" value="Restore"/>
RTS Threshold	<input type="text" value="2347"/>	(Range: 1 - 2347; Default: 2347)	<input type="button" value="Help"/>
DTIM Interval	<input type="text" value="1"/>	(Range: 1 - 255; Default: 1)	
Min. RSSI Threshold	<input type="radio"/> Enable <input checked="" type="radio"/> Disable		
Interference Mitigation	<input type="text" value="2"/>	(Range: 0 - 3; Default: 2)	
Transmit Power	<input type="text" value="20"/>	dBm (Range: 8 - 20; Default: 20)	
Lock Power	<input checked="" type="checkbox"/>		
Preamble	<input checked="" type="radio"/> Long Preamble <input type="radio"/> Short Preamble		

--End

Parameter description

Parameter	Description
Beacon Interval	<p>It specifies the interval for transmitting the Beacon frame.</p> <p>The Beacon frame is transmitted at the specified interval to announce the presence of a wireless network. Generally, a smaller interval enables wireless clients to connect to the AP more quickly, while a larger interval ensures higher data transmission efficiency.</p>

Parameter	Description
Fragment Threshold	<p>It specifies the threshold of a fragment. The unit is byte.</p> <p>Fragmenting is a process that divides a frame into several fragments, which are transmitted and acknowledged separately. If the size of a frame exceeds this threshold, the frame is fragmented.</p> <p>In case of a high error rate, you can reduce the threshold to enable the AP to resend only the fragments that have not been sent successfully, so as to increase the frame throughput.</p> <p>In an environment without interference, you can increase the threshold to reduce the number of acknowledgement times, so as to increase the frame throughput.</p>
RTS Threshold	<p>It specifies the frame length threshold for triggering the RTS/CTS mechanism.</p> <p>If a frame exceeds this threshold, the RTS/CTS mechanism is triggered to reduce conflicts. The unit is byte.</p> <p>Set the RTS threshold based on the actual situation. An excessively small value increases the RTS frame transmission frequency and bandwidth requirement. A higher RTS frame transmission frequency enables a wireless network to recover from conflicts quicker. For a wireless network with high user density, you can reduce this threshold for reducing conflicts.</p> <p>The RTS mechanism requires some network bandwidth. Therefore, it is triggered only when frames exceed this threshold.</p>
DTIM Interval	<p>It specifies the interval for transmitting the Delivery Traffic Indication Message (DTIM) frame. The unit is Beacon.</p> <p>A countdown starts from this value. The AP transmits broadcast and multicast frames in its cache only when the countdown reaches zero.</p> <p>For example, if DTIM Interval is set to 1, the AP transmits all cached frames after each beacon frame is transmitted.</p>
Min. RSSI Threshold	<p>It specifies the minimum strength of received signals acceptable to the AP. If the strength of the signals transmitted by a wireless device is weaker than this threshold, the wireless device cannot connect to the AP.</p> <p>If there are multiple APs, an appropriate value of this parameter ensures that wireless clients connect to the APs with strong signals.</p>
Interference Mitigation	<p>Interference mitigation mode. The default is 2.</p> <ul style="list-style-type: none"> • 0: Disable all interference mitigation. • 1: Enable interference mitigation from the same frequency band, like interference from microwave oven, smartphone, or Bluetooth device. • 2: Compulsively enable radio waves interference mitigation. • 3: Automatically enable radio waves interference mitigation.
Transmit Power	<p>It specifies the transmit power of the AP. Higher transmitted power contributes to wider wireless coverage. But reducing the transmitted power properly can improve the security of your wireless network.</p>

Parameter	Description
Lock Power	It specifies whether the current transmit power settings of the AP can be changed. If it is selected, the settings cannot be changed.
Preamble	<p>It specifies whether to use long preamble or short preamble. A preamble is a group of bits located at the beginning of a packet to enable a receiver of the packet to perform synchronization and prepare for receiving data.</p> <p>By default, the Long Preamble option is selected for compatibility with old network adapters installed on wireless clients. To achieve better synchronization performance of networks, you can select the Short Preamble option.</p>

7.6 Access Control

7.6.1 Overview

It specifies, based on MAC address filter rules, the wireless devices that can or cannot access the wireless networks of the AP. Devices that have been controlled cannot connect to the corresponding wireless network.

The AP supports the following MAC address filter rules:

- **Disable:** It indicates that access control is disabled.
- **Allow:** It indicates that only the wireless devices with the specified MAC addresses can access the wireless networks of the AP.
- **Disallow:** It indicates that only the wireless devices with the specified MAC addresses cannot access the wireless networks of the AP.

7.6.2 Configuring access control

Step 1 Choose **Wireless > Access Control**.

Step 2 From the **SSID** drop-down list box, select the SSID of the wireless network on which access control must be implemented.

Step 3 Select an access control mode from the **MAC Filter Mode** drop-down list box.

Step 4 If you select **Allow** or **Disallow**, enter the MAC addresses to control in the access control list and click **Add**.



TIP

If a wireless device to be controlled has been connected to the AP, you can click **Add** corresponding to the device in the wireless client list to directly add it to the access control list.

Step 5 Click **Save**.

--End

Parameter description

Parameter	Description
SSID	It specifies the SSID that requires wireless client access control.
MAC Filter Mode	<p>It specifies the mode for filtering MAC addresses.</p> <ul style="list-style-type: none">• Disable: It indicates that access control is disabled.• Allow: It indicates that only the wireless clients on the access control list can connect to the AP with the selected SSID.• Disallow: It indicates that only the wireless clients on the access control list cannot connect to the AP with the selected SSID.

7.6.3 Example of configuring access control

Networking requirement

A wireless network whose SSID is **Home** has been set up in a large apartment. Only family members are allowed to connect to the wireless network.

The Access Control function of the AP is recommended. The family members have three wireless devices whose MAC addresses are C8:3A:35:00:00:01, C8:3A:35:00:00:02, and C8:3A:35:00:00:03.

Configuration procedure:

Step 1 Choose **Wireless > Access Control**.

Step 2 Select **Home** from the **SSID** drop-down list box.

Step 3 Select **Allow** from the **MAC Filter Mode** drop-down list box.

Step 4 Enter **C8:3A:35:00:00:01** in the **MAC Address** text box and click **Add**. Repeat this step to add **C8:3A:35:00:00:02** and **C8:3A:35:00:00:03** as well.

Step 5 Click **Save**.

--End

The following figure shows the configuration.

Access Control

You can specify MAC address filter rules to allow or disallow wireless devices to connect to the wireless networks of the AP.

SSID: Home

MAC Filter Mode: Allow

Save

Restore

Help

ID	MAC Address	IP	Connection Uptime	Add to List
No client connected.				

MAC Address	Operation
C8 : 3A : 35 : 00 : 00 : 03	Add

1	C8:3A:35:00:00:01	<input checked="" type="checkbox"/> Enable	Delete
2	C8:3A:35:00:00:02	<input checked="" type="checkbox"/> Enable	Delete
3	C8:3A:35:00:00:03	<input checked="" type="checkbox"/> Enable	Delete

Verification

Only the specified wireless devices can connect to the **Home** wireless network.

7.7 QVLAN Settings

7.7.1 Overview

The AP supports 802.1Q VLANs and is applicable in a network environment where 802.1Q VLANs have been defined. By default, the QVLAN function is disabled.

7.7.2 Configuring the QVLAN function

Step 1 Choose **Wireless > QVLAN Setup**.

Step 2 Change the parameters as required. Generally, you only need to change the **Enable**, and VLAN ID settings.

Step 3 Click **Save**.

QVLAN Setup

* Enable

PVID

Management VLAN

* 2.4G SSID	VLAN ID (1~4094)
Home	<input type="text" value="1000"/>

Save

Restore

Help

--End

Parameter description

Parameter	Description
Enable	It specifies whether to enable the QVLAN function of the AP. By default, it is disabled.
PVID	It specifies the ID of the default native VLAN of the trunk port of the AP. The default value is 1 .
Management VLAN	It specifies the ID of the AP management VLAN. The default value is 1 . After changing the management VLAN, you can manage the AP only after connecting your computer or AP controller to the new management VLAN.
2.4G SSID	It specifies the currently enabled 2.4 GHz SSIDs of the AP.
VLAN ID	It specifies VLAN IDs corresponding to SSIDs. The default value is 1000 . After the QVLAN function is enabled, the wireless interfaces corresponding to SSIDs functions as access ports. The PVID and VLAN ID of an access port are the same.

If the QVLAN function is enabled, tagged data received by a port of the AP is forwarded to the other ports of the VLAN corresponding to the VID in the data, whereas untagged data received by a port of the AP is forwarded to the other ports of the VLAN corresponding to the PVID of the port that receives the data.

The following table describes how ports of different link types process transmitted and received data.

Port	Method to Process Received Data		Method to Process Transmitted Data
	Tagged Data	Untagged Data	
Access	Forward the data to other ports of the VLAN corresponding to the VID in the data.	Forward the data to the other ports of the VLAN corresponding to the PVID of the port that receives the data	Transmit data after removing tags from the data.
Trunk			If the VID and PVID of a port are the same, transmit data after removing tags from the data. If the VID and PVID of a port are different, transmit data without removing tags from the data.

7.7.3 Example of configuring QVLAN settings

Networking requirement

A hotel has the following wireless network coverage requirements:

- Guests are connected to VLAN 2 and can access only the internet.
- Employees are connected to VLAN 3 and can access only the internal server.
- Managers of the hotel are connected to VLAN 4 and can access the internet and the internal server.

Assumption

The AP enables wireless networks and configures the following SSIDs.

- SSID of the wireless network for guests: **internet**
- SSID of the wireless network for employees: **oa**
- SSID of the wireless network for hotel managers: **VIP**

Network Topology

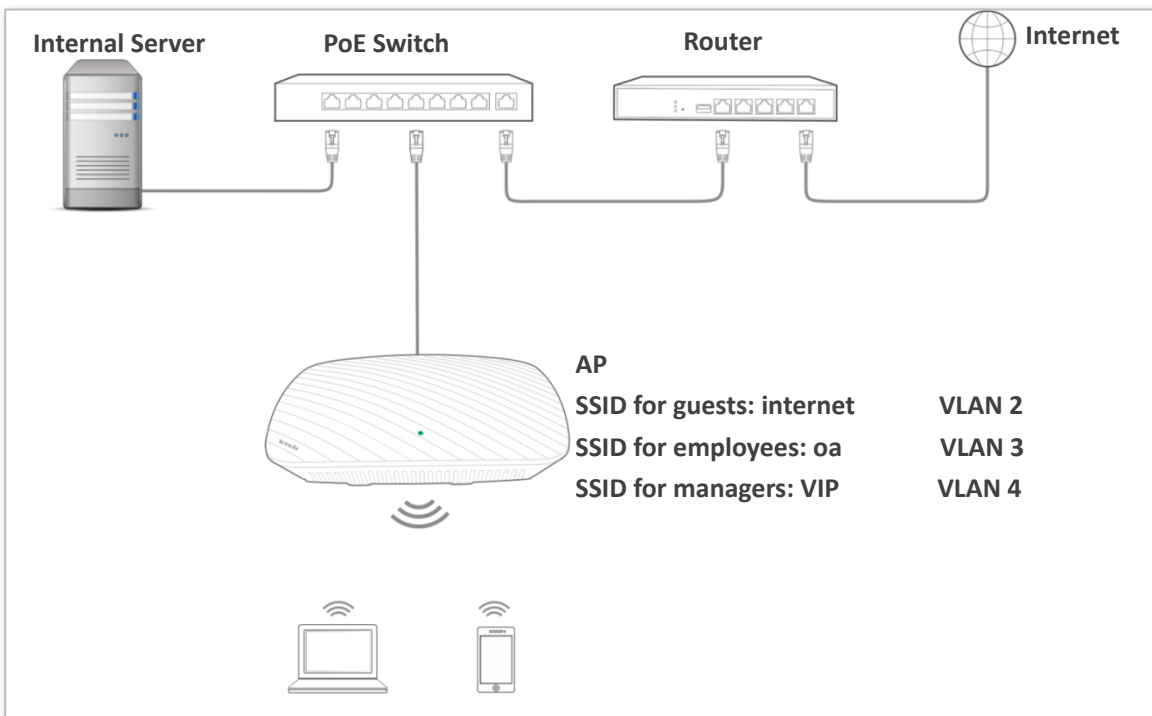

Configuration procedure:

■ Configure the AP

- Step 1** Log in to the web UI of the AP and choose **Wireless > QVLAN Setup**.
- Step 2** Select the **Enable** check box.
- Step 3** Change the **VLAN ID** of the SSID **internet** to **2**, the **VLAN ID** of the SSID **oa** to **3**, and the **VLAN ID** of the SSID **VIP** to **4**.
- Step 4** Click **Save**.

QVLAN Setup

Enable *

PVID

Management VLAN

2.4G SSID	VLAN ID (1~4094)
internet	<input type="text" value="2"/> *
VIP	<input type="text" value="4"/> *
oa	<input type="text" value="3"/> *

Save

Restore

Help

--End

Wait for the automatic reboot of the AP.

■ Configure the switch

Create IEEE 802.1Q VLANs described in the following table on the switch.

Port Connected To	Accessible VLAN ID	Port Type	PVID
AP	1, 2, 3, 4	Trunk	1
LAN server	3, 4	Trunk	1
Router	2, 4	Trunk	1

Retain the default settings of other ports. For details, refer to the user guide for the switch.

■ Configure the router and the internal server

To ensure that wireless devices connected to the AP can access the internet, the router and internal server are required to support the QVLAN function. Refer to the following details:

For the router:

Port Connected To	Accessible VLAN ID	Port Type	PVID
Switch	2, 4	Trunk	1

For the internal server:

Port Connected To	Accessible VLAN ID	Port Type	PVID
Switch	3, 4	Trunk	1

For details of configuration procedure, refer to the user guide of the router and the internal server.

--End

Verification

Wireless clients connected to the **internet** wireless network can access only the internet, the wireless clients connected to the **oa** wireless network can access only the internal server, and wireless clients connected to **VIP** wireless network can both access the internet and the internal server.

8 SNMP

8.1 Overview

The Simple Network Management Protocol (SNMP) is the most widely used network management protocol in TCP/IP networks. SNMP enables you to remotely manage all your network devices compliant with this protocol, such as monitoring the network status, changing network device settings, and receive network event alarms.

SNMP allows automatic management of devices from various vendors regardless of physical differences among the devices.

8.1.1 SNMP management framework

The SNMP management framework consists of SNMP manager, SNMP agent, and Management Information Base (MIB).

- SNMP manager: It is a system that controls and monitors network nodes using the SNMP protocol. The SNMP manager most widely used in network environments is Network Management System (NMS). An NMS can be a dedicated network management server, or an application that implements management functions in a network device.
- SNMP agent: It is a software module in a managed device. The module is used to manage data about the device and report the management data to an SNMP manager.
- MIB: It is a collection of managed objects. It defines a series of attributes of managed objects, including names, access permissions, and data types of objects. Each SNMP agent has its MIB. An SNMP manager can read and/or write objects in the MIB based on the permissions assigned to the SNMP manager.

An SNMP manager manages SNMP agents in an SNMP network. The SNMP manager exchanges management information with the SNMP agents using the SNMP protocol.

8.1.2 Basic SNMP operations

The AP allows the following basic SNMP operations:

- Get: An SNMP manager performs this operation to query the SNMP agent of the AP for values of one or more objects.
- Set: An SNMP manager performs this operation to set values of one or more objects in the MIB of the SNMP agent of the AP.

8.1.3 SNMP protocol version

The AP is compatible with SNMP V1 and SNMP V2C and adopts the community authentication mechanism. Community name is used to define the relationship between an SNMP agent and an SNMP manager. If the community name contained in an SNMP packet is rejected by a device, the packet is discarded. A community name functions as a password to control SNMP agent access attempts of SNMP managers.

SNMP V2C is compatible with SNMP V1 and provides more functions than SNMP V1. Compared with SNMP V1, SNMP V2C supports more operations (GetBulk and InformRequest) and data types (such as Counter64), and provides more error codes for better distinguishing errors.

8.1.4 MIB introduction

An MIB adopts a tree structure. The nodes of the tree indicate managed objects. A path consisting of digits and starting from the root can be used to uniquely identify a node. This path is called an object identifier (OID). The following figure shows the structure of an MIB. In the figure, the OID of A is 1.3.6.1.2.1.1, whereas the OID of B is 1.3.6.1.2.1.2.

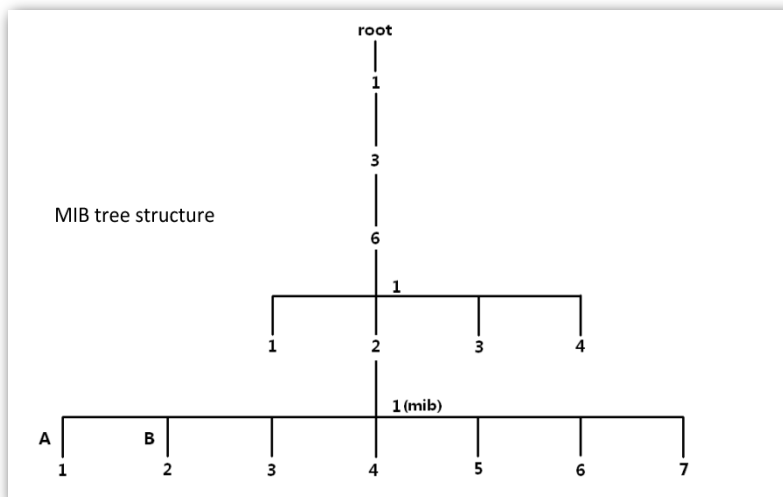

8.2 Configuring the SNMP function

Step 1 Choose **SNMP** and set **SNMP Agent** to **Enable**.

Step 2 Set related SNMP parameters.

Step 3 Click **Save**.

SNMP

You can configure SNMP V1 or SNMP V2C settings here.

SNMP Agent Disable Enable

Administrator

AP Name

Location

Read Community

Read/Write Community

--End

Parameter description

Parameter	Description
SNMP Agent	It specifies whether to enable the SNMP agent function of the AP. By default, it is disabled. An SNMP manager and the SNMP agent can communicate with each other only if their SNMP versions are the same. Currently, the SNMP agent function of the AP supports SNMP V1 and SNMP V2C.
Administrator	It specifies the name of the administrator of the AP. The default name is Administrator . You can change the location as required.
AP Name	It specifies the name of the AP. The default device name is in the format of Model + Hardware version number.  TIP It is recommended that you change the AP name so that you can easily identify the AP when managing the AP using SNMP.
Location	It specifies the location where the AP is used. You can change the location as required.
Read Community	It specifies the read password shared between SNMP managers and this SNMP agent. The default password is public . The SNMP agent function of the AP allows an SNMP manager to use the password to read variables in the MIB of the AP.
Read/Write Community	It specifies the read/write password shared between SNMP managers and this SNMP agent. The default password is private . The SNMP agent function of the AP allows an SNMP manager to use the password to read/write variables in the MIB of the AP.

8.3 Example of configuring the SNMP function

Networking requirement

- The AP connects to an NMS over an LAN. This IP address of the AP is 192.168.0.254/24 and the IP address of the NMS is 192.168.0.212/24.
- The NMS use SNMP V1 or SNMP V2C to monitor and manage the AP.

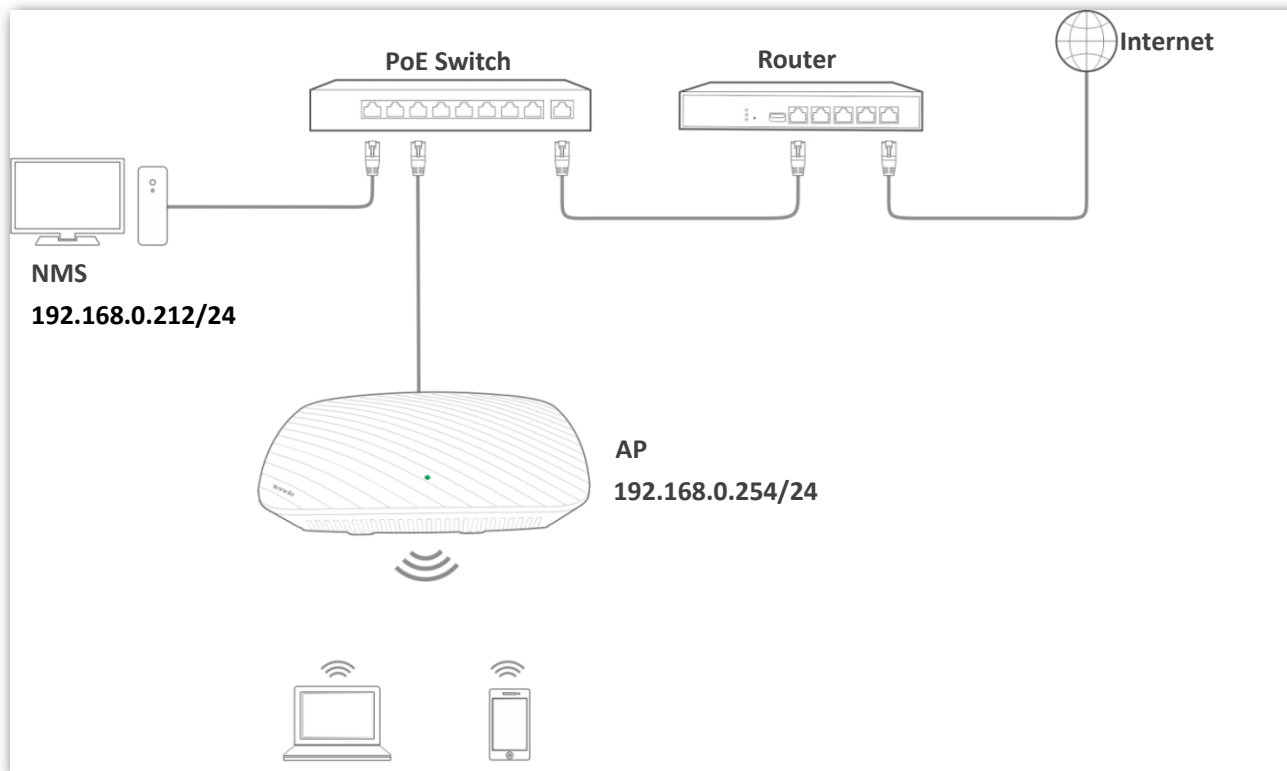

Configuration procedure

■ Configure the AP

Assume that the administrator name is **Tom**, read community is **Tom**, and read/write community is **Tom123**.

Step 1 Log in to the web UI of the AP and choose **SNMP**.

Step 2 Set **SNMP Agent** to **Enable**.

Step 3 Set the SNMP parameters.

Step 4 Click **Save**.

SNMP

You can configure SNMP V1 or SNMP V2C settings here.

SNMP Agent Disable Enable

Administrator

AP Name

Location

Read Community

Read/Write Community

Save

Restore

Help

--End

■ Configure the NMS

On an NMS that uses SNMP V1 or SNMP V2C, set the read community to **Tom** and read/write community to **Tom 123**. For details about how to configure the NMS, refer to the configuration guide for the NMS.

Verification

After the configuration, the NMS can connect to the SNMP agent of the AP and can query and set some parameters on the SNMP agent through the MIB.

9 Tools

9.1 Firmware Upgrade

This function upgrades the firmware of the AP for more functions and higher stability.



To prevent damaging the AP, verify that the new firmware version is applicable to the AP before upgrading the firmware and keep the power supply of the AP connected during an upgrade.

Configuration procedure:

- Step 1** Download the package of a later firmware version for the AP from <http://www.tendacn.com> to your local computer, and decompress the package.
- Step 2** Log in to the web UI of the AP and choose **Tools > Firmware Upgrade**.
- Step 3** Click **Choose File** and select the file for upgrading the firmware.
- Step 4** Click **Upgrade**.

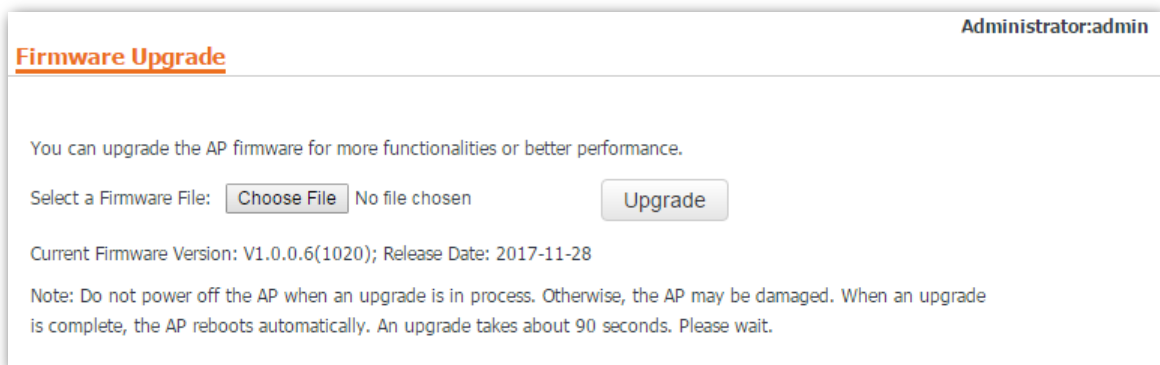

The screenshot shows the 'Firmware Upgrade' page in a web browser. The page title is 'Firmware Upgrade' and the user is logged in as 'Administrator:admin'. The main content area contains the following text: 'You can upgrade the AP firmware for more functionalities or better performance.' Below this is a 'Select a Firmware File:' label, a 'Choose File' button, and the text 'No file chosen'. To the right of this is an 'Upgrade' button. Below the file selection area, it says 'Current Firmware Version: V1.0.0.6(1020); Release Date: 2017-11-28'. At the bottom, a note reads: 'Note: Do not power off the AP when an upgrade is in process. Otherwise, the AP may be damaged. When an upgrade is complete, the AP reboots automatically. An upgrade takes about 90 seconds. Please wait.'

--End

Wait until the progress bar is complete. Log in to the web UI of the AP again. Choose **Status > System Status** and check whether the upgrade is successful based on **Firmware Version**.



After the firmware is upgraded, you are recommended to restore the factory settings of the AP and configure the AP again, so as to ensure stability of the AP and proper operation of new functions.

9.2 Time & Day

This module enables you to set the [system time](#) and [login timeout](#) interval of the AP.

9.2.1 System Time

Ensure that the system time of the AP is correct, so that logs can be recorded correctly and the reboot schedule can be executed correctly.

To access the page, choose **Tools > Date & Time**.

The screenshot shows the 'System Time' configuration page. At the top, there are two tabs: 'System Time' (selected) and 'Login Timeout'. Below the tabs, there is a text box stating: 'You can configure the system time of the AP here.' To the right of this text are three buttons: 'Save', 'Restore', and 'Help'. Below this is a note: 'Note: The system time is lost when the AP is turned off. It will be synchronized with the GMT time automatically when the AP is turned on and connected to the internet again.' There is a checked checkbox labeled 'Synchronize with internet time' and a 'Sync Interval' dropdown menu set to '30 minutes'. Below that is a 'Time Zone' dropdown menu set to '(GMT+08:00) Beijing, Chongqing, Hong Kong, Urumqi, Taipei'. Another note follows: 'Note: The system is automatically synchronized with the GMT time only after the AP is connected to the Internet.' At the bottom, there is a section 'Enter Date and Time:' with input fields for Year (2018), Month (10), Day (12), Hour (44), Minute (39), and Second (s). A 'Synchronize with PC Time' button is located to the right of these fields.

The AP allows you to set the system time by synchronizing the time with the internet or manually setting the time. By default, it is configured to synchronize the system time with the internet.

Synchronizing with internet time servers

The AP automatically synchronizes its system time with a time server of the internet. This enables the AP to automatically correct its system time after being connected to the internet.

For details about how to connect the AP to the internet, refer to [LAN Setup](#).

Procedure for configuring the AP to synchronize its system time with the internet:

- Step 1** Choose **Tools > Date & Time > System Time**.
- Step 2** Select the **Synchronize with internet time** check box.
- Step 3** Set **Sync Interval** to the interval at which the AP synchronizes its system time with a time server of the internet. The default value 30 minutes is recommended.
- Step 4** Set **Time Zone** to your time zone.
- Step 5** Click **Save**.

System Time **Login Timeout**

You can configure the system time of the AP here.

Note: The system time is lost when the AP is turned off. It will be synchronized with the GMT time automatically when the AP is turned on and connected to the internet again.

Synchronize with internet time Sync Interval: 30 minutes

Time Zone: (GMT+08:00) Beijing, Chongqing, Hong Kong, Urumqi, Taipei

Note: The system is automatically synchronized with the GMT time only after the AP is connected to the Internet.

Enter Date and Time:

2018 Y 10 M 12 D 13 h 44 m 39 s Synchronize with PC Time

Save Restore Help

--End

Manually setting the system time

You can manually set the system time of the AP. If you choose this option, you need to set the system time each time after the AP reboots.

Configuration procedure:

- Step 1** Choose **Tools > Date & Time > System Time**.
- Step 2** Deselect **Sync with internet time servers**.
- Step 3** Enter a correct date and time, or click **Sync with Your PC** to synchronize the system time of the AP with the system time (ensure that it is correct) of the computer being used to manage the AP.
- Step 4** Click **Save**.

System Time **Login Timeout**

You can configure the system time of the AP here.

Note: The system time is lost when the AP is turned off. It will be synchronized with the GMT time automatically when the AP is turned on and connected to the internet again.

Synchronize with internet time Sync Interval: 30 minutes

Time Zone: (GMT+08:00) Beijing, Chongqing, Hong Kong, Urumqi, Taipei

Note: The system is automatically synchronized with the GMT time only after the AP is connected to the Internet.

Enter Date and Time:

2018 Y 10 M 12 D 13 h 44 m 39 s Synchronize with PC Time

Save Restore Help

--End

9.2.2 Login Timeout

If you log in to the web UI of the AP and perform no operation within the login timeout interval, the AP logs you out for network security. The default login timeout interval is 5 minutes.

Procedure for setting the login timeout interval:

Step 1 Choose **Tools > Date & Time**, and click the **Login Timeout** tab.

Step 2 Change the login timeout interval as required.

Step 3 Click **Save**.

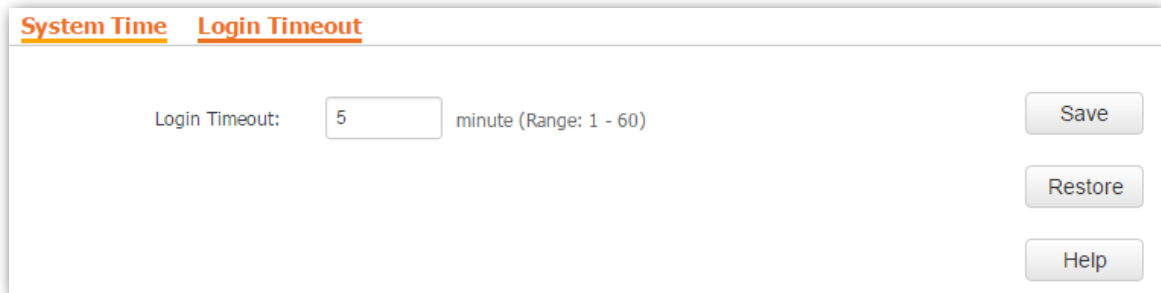

The screenshot shows a web interface with two tabs: "System Time" and "Login Timeout". The "Login Timeout" tab is active. Below the tabs, there is a label "Login Timeout:" followed by a text input field containing the number "5". To the right of the input field, it says "minute (Range: 1 - 60)". On the right side of the form, there are three buttons: "Save", "Restore", and "Help".

--End

9.3 Logs

9.3.1 View Logs

The logs of the AP record various events that occur and the operations that users perform after the AP starts. In case of a system fault, you can refer to the logs during troubleshooting.

To access the page, choose **Tools > Logs** and click **View Logs**.

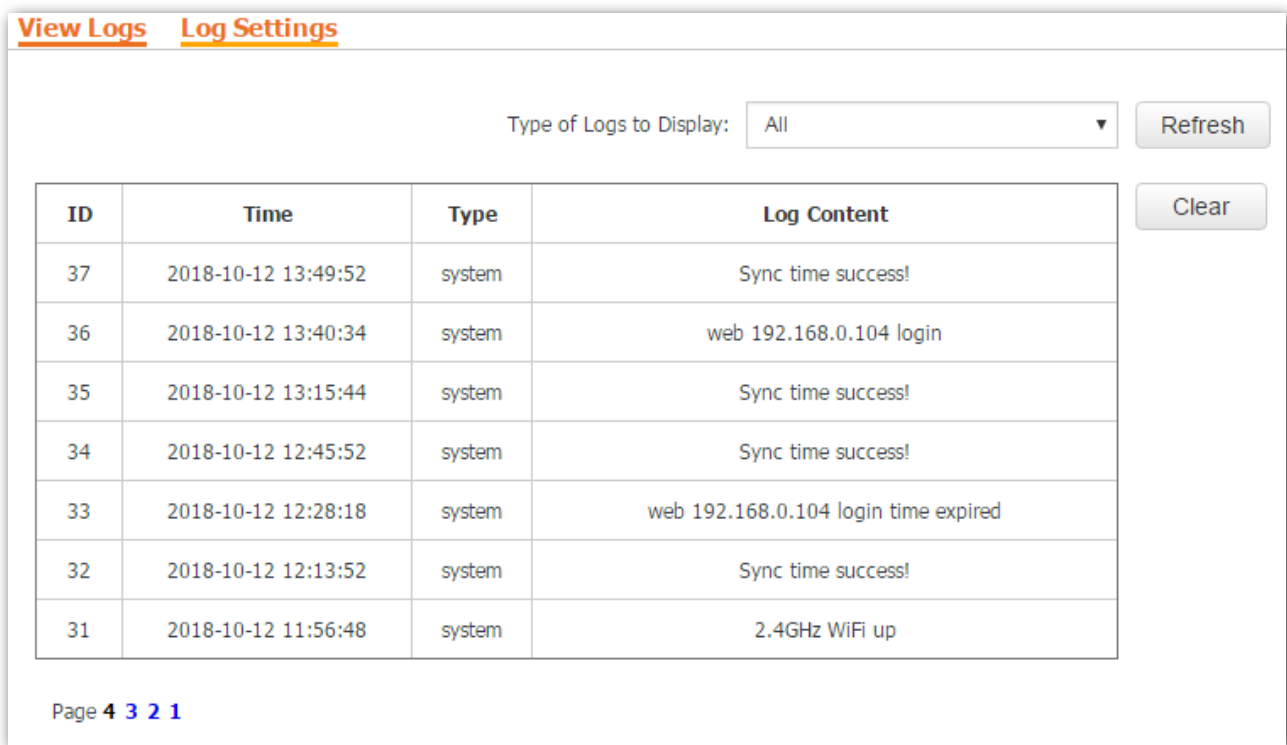

The screenshot shows the 'View Logs' interface. At the top, there are two tabs: 'View Logs' (active) and 'Log Settings'. Below the tabs, there is a dropdown menu labeled 'Type of Logs to Display:' with 'All' selected, and a 'Refresh' button. Below the dropdown and buttons is a table with the following columns: ID, Time, Type, and Log Content. The table contains 7 rows of log entries. At the bottom right of the table area is a 'Clear' button. At the bottom left of the interface, it says 'Page 4 3 2 1'.

ID	Time	Type	Log Content
37	2018-10-12 13:49:52	system	Sync time success!
36	2018-10-12 13:40:34	system	web 192.168.0.104 login
35	2018-10-12 13:15:44	system	Sync time success!
34	2018-10-12 12:45:52	system	Sync time success!
33	2018-10-12 12:28:18	system	web 192.168.0.104 login time expired
32	2018-10-12 12:13:52	system	Sync time success!
31	2018-10-12 11:56:48	system	2.4GHz WiFi up

To ensure that the logs are recorded correctly, verify the system time of the AP. You can correct the system time of the AP by choosing **Tools > Date & Time > System Time**.

To view the latest logs of the AP, click **Refresh**. To clear the existing logs of the AP, click **Clear**.



- When the AP reboots, the previous logs are lost.
- The AP reboots when the AP is powered on after a power failure, the QVLAN function is configured, the firmware is upgraded, an AP configuration is backed up or restored, or the factory settings are restored.

9.3.2 Log settings

To access the page, choose **Tools > Logs** and click **Log Settings**.

On this page, you can set the number of logs to be displayed and configure log servers.

The screenshot shows the 'Log Settings' page. At the top, there are two tabs: 'View Logs' and 'Log Settings'. Below the tabs, there is a form with the following elements:

- A label 'Number of Logs Displayed' followed by a text input field containing '150'. To the right of the field is the text '(Range: 100 - 300; Default: 150)'. To the right of the field is a 'Save' button.
- A checkbox labeled 'Enable Log Server Function'.
- A table with the following columns: 'ID', 'Log Server IP Address', 'Log Server Port', 'Enable', and 'Operation'.
- An 'Add' button located below the table.
- Buttons for 'Restore' and 'Help' are located to the right of the table.

■ Setting the number of logs to be displayed

By default, the AP can display a maximum of 150 logs on the View Logs page. You can change the number as required.

Configuration procedure:

Step 1 To access the page, choose **Tools > Logs** and click **Log Settings**.

Step 2 Change the number of logs as required within the range of 100 to 300.

Step 3 Click **Save**.

This screenshot is identical to the one above, but with an asterisk (*) next to the 'Number of Logs Displayed' label, indicating that this field is required.

--End

■ Configuring log server settings

After a log server is specified, the AP sends its logs to the log server. You can view all the historical logs of the AP on the log server.



To ensure that system logs can be sent to a log server, choose **Network > LAN Setup** and set the IP address, subnet mask, and gateway of the AP for communicating with the log server.

Procedure for adding a log server:

Step 1 To access the page, choose **Tools > Logs** and click **Log Settings**.

Step 2 Click **Add**.

The screenshot shows the 'Log Settings' page with the following elements:

- Number of Logs Displayed: 150 (Range: 100 - 300; Default: 150)
- Enable Log Server Function:
- Buttons: Save, Restore, Help, Add
- Table with columns: ID, Log Server IP Address, Log Server Port, Enable, Operation

Step 3 Set parameters as follows:

- Set **Log Server IP** to the IP address of the log server.
- Set **Log Server Port** to the UDP port number used to send and receive system logs. The default port number 514 is recommended.
- Select **Enable** to enable this log server rule.

Step 4 Click **Save**.

The screenshot shows the 'Log Settings' page with the following elements:

- Log Server IP Address:
- Log Server Port: 514
- Enable:
- Buttons: Save, Restore, Help

Step 5 Select **Enable Log Server** function.

Step 6 Click **Save**.

--End

The following figure shows the configuration.

View Logs **Log Settings**

Number of Logs Displayed: (Range: 100 - 300; Default: 150)

Enable Log Server Function

ID	Log Server IP Address	Log Server Port	Enable	Operation
1	192.168.0.88	514	Enable	<input type="button" value="Change"/> <input type="button" value="Delete"/>

Procedure for changing log server settings

- Step 1** To access the page, choose **Tools > Logs** and click **Log Settings**.
- Step 2** Click **Change** corresponding to the log server settings to be changed.
- Step 3** Change the parameter settings as required.
- Step 4** Click **Save**.

--End

Procedure for deleting log server settings

- Step 1** To access the page, choose **Tools > Logs** and click **Log Settings**.
- Step 2** Click **Delete** corresponding to the log server settings to be deleted.

--End

9.4 Configuration

9.4.1 Backup & Restore

The backup function enables you to back up the current configuration of the AP to a local computer. The restoration function enables you to restore the AP to a previous configuration.

If the AP enters the optimum condition after you greatly change the configuration of the AP, you are recommended to back up the new configuration, so that you can restore it after upgrading or resetting the AP.



If you need to apply same or similar configurations to many APs, you can configure one of the APs, back up the configuration of the AP, and use the backup to restore the configuration on the other APs. This improves configuration efficiency.

Backing Up the Current Configuration

Step 1 Choose **Tools > Configuration > Backup & Restore**.

Step 2 Click **Backup** and follow the on-screen instructions to perform operations.

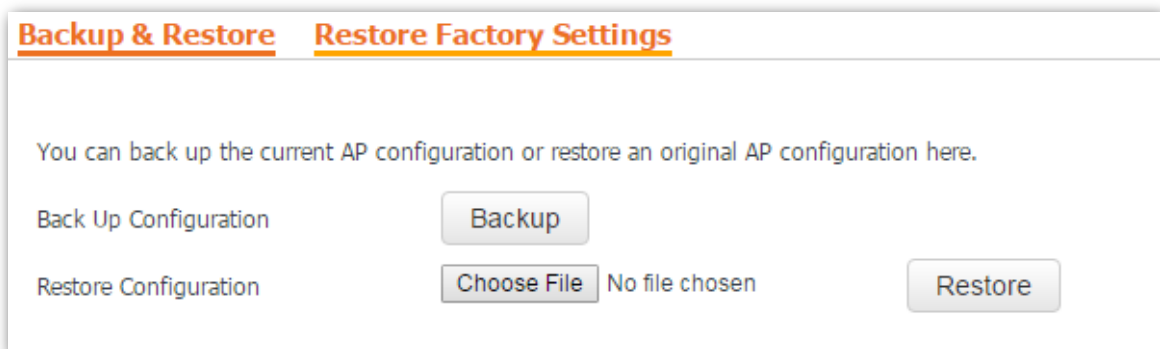

--End

Restoring a Configuration

Step 1 Choose **Tools > Configuration > Backup & Restore**.

Step 2 Click **Choose File** and select the file of the configuration to be restored.

Step 3 Click **Restore** and follow the on-screen instructions to perform operations.

--End

9.4.2 Restoring the Factory Settings

If you cannot locate a fault of the AP or forget the password of the web UI of the AP, you can reset the AP to restore its factory settings and then configure it again. The AP can be reset using software or hardware.

After the factory settings are restored, the login IP address of the AP is changed to **192.168.0.254**, and the user name and password of the AP are changed to **admin**.



- When the factory settings are restored, your configuration is lost. Therefore, you need to reconfigure the AP to connect to the internet. Restore the factory settings of the AP only when necessary.
- To prevent AP damages, ensure that the power supply of the AP is normal when the AP is reset.

Restoring the Factory Settings Using Software

Step 1 Choose **Tools > Configuration** and click the **Restore to Factory Default** tab.

Step 2 Click the **Restore to Factory Default** button.

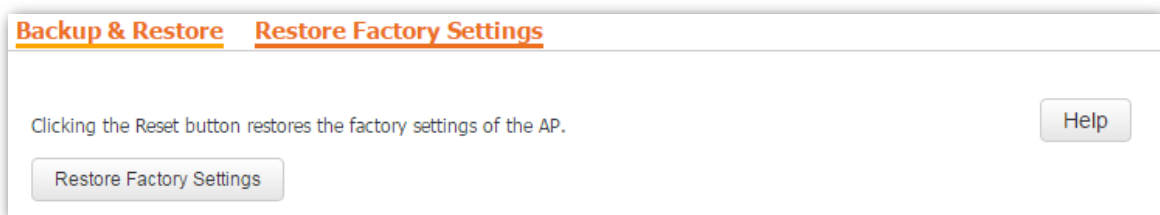

--End

Restoring the factory settings using hardware

This method enables you to restore the factory settings without logging in to the web UI of the AP.

Configuration procedure:

Step 1 When the AP is working properly, hold down the reset button for 8 seconds.

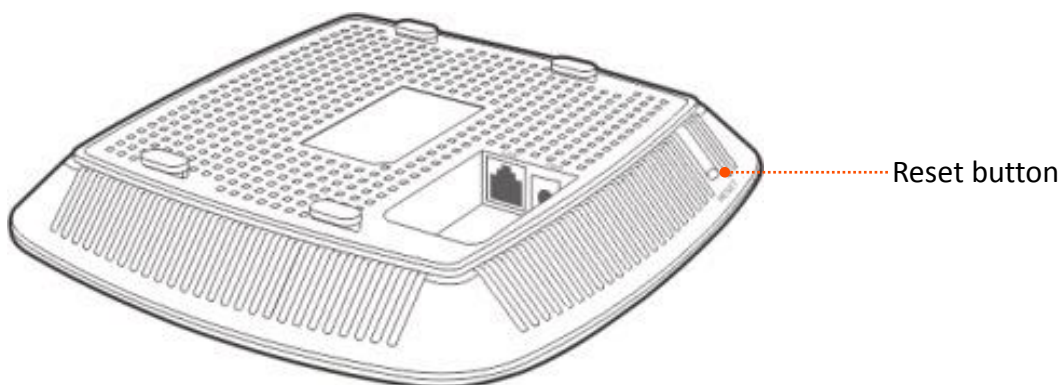

Step 2 Wait about 1 minute.

--End

9.5 Account

To access page for changing user names and passwords, choose **Tools > Account**.

On this page, you can change the login account information of the AP to prevent unauthorized login.

Account

You can change your login user name and password here.
Note: Only 1 to 32 letters, digits, and underscores are allowed in a user name or password.

Account Type	User Name	Enable	Operation
Administrator	admin	<input checked="" type="checkbox"/>	<input type="button" value="Change"/>
User	user	<input checked="" type="checkbox"/>	<input type="button" value="Delete"/> <input type="button" value="Change"/>

Parameter description

Parameter	Description
Account Type	<ul style="list-style-type: none">• Administrator: An account of this type enables you to view and modify settings of the AP.• User: An account of this type enables you to view settings of the AP.
User Name	<p>It specifies the user name of an account.</p> <p>By default, the AP has one administrator account and one user account. Both the user name and password of the administrator account are admin. Both the user name and password of the user account are user.</p>
Enable	<p>It specifies whether an account is enabled.</p> <ul style="list-style-type: none">• The administrator account is always enabled.• The user account is enabled by default and can be disabled.
Operation	<p>Change: This button is used to change the user name and password of the account corresponding to the button.</p> <p>Delete: This button is used to delete the user account.</p>

 **NOTE**

After changing or deleting an account, click **Save**.

9.6 Diagnostics Tool

If the network connection fails, you can use the diagnostics tool included with the AP to locate the faulty node.

Configuration procedure:

The link to www.google.com is used as an example.

Step 1 Choose **Tools > Diagnostics**.

Step 2 Enter the IP address or domain name to be pinged in the **Input** text box. In this example, enter **www.google.com**.

Step 3 Click **ping**.

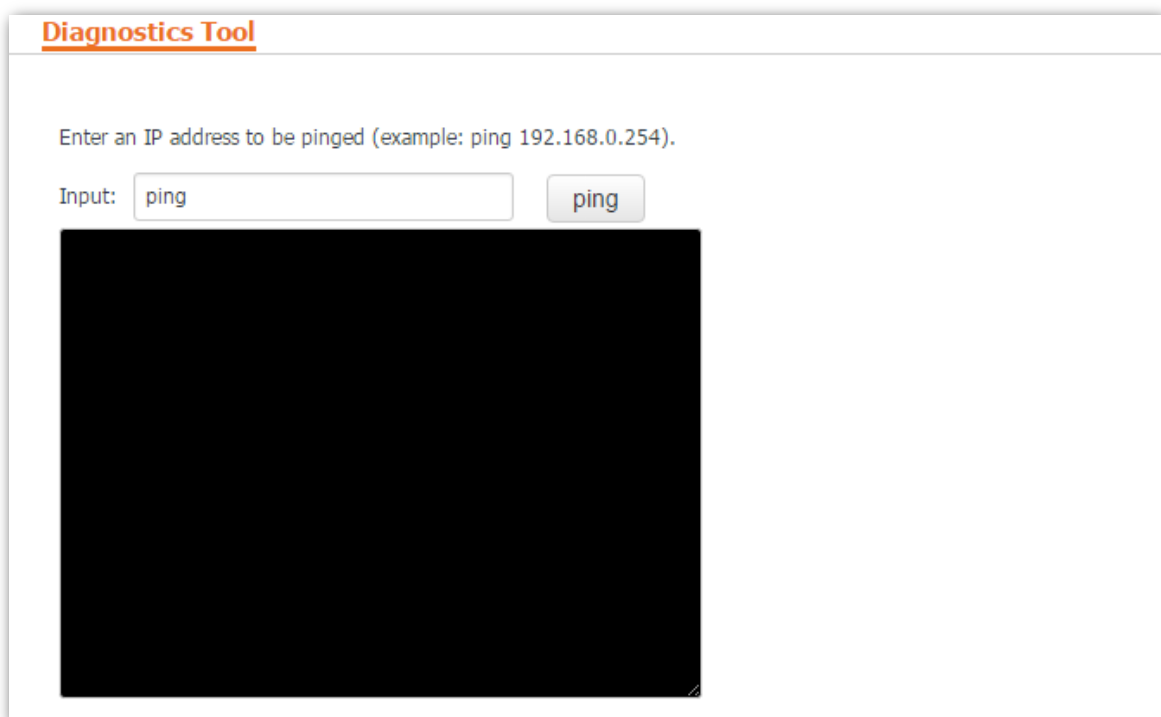

Diagnostics Tool

Enter an IP address to be pinged (example: ping 192.168.0.254).

Input:

[A large black rectangular area is present below the input field, intended for displaying the ping results.]

--End

The diagnosis result will be displayed in a few seconds in the black text box. See the following figure.

Diagnostics Tool

Enter an IP address to be pinged (example: ping 192.168.0.254).

Input:

```
PING www.google.com (31.13.72.54): 56 data bytes
```

```
— www.google.com ping statistics —
```

```
3 packets transmitted, 0 packets received, 100% packet loss
```

9.7 Device Reboot

This module enables you to manually reboot the AP or configure the AP to automatically reboot.



When the AP reboots, all connections are released. You are recommended to reboot the AP at an idle hour.

9.7.1 Manual Reboot

If a setting does not take effect, you can try rebooting the AP to resolve the problem.

Configuration procedure:

Step 1 To access the page, choose **Tools > Device Reboot**.

Step 2 Click **Reboot**.

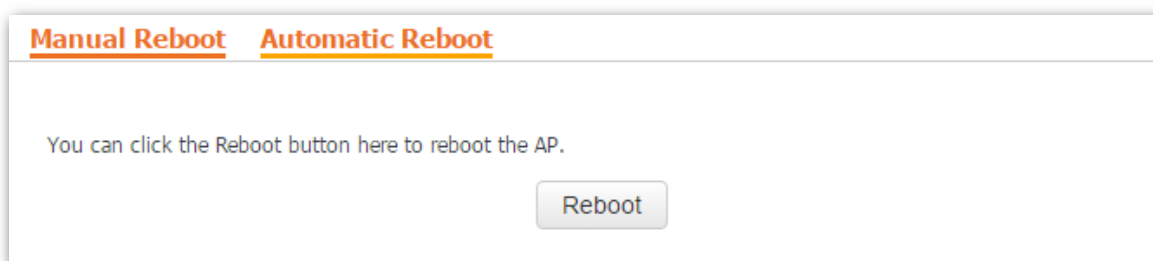

--End

9.7.2 Automatic Reboot

Automatic Reboot allows you to reboot the AP at your specified time to avoid unstable WLAN performance due to long- time running. The AP supports the following two ways of automatic reboot.

Rebooting the AP at an interval

Configuration procedure:

Step 1 Choose **Tools > Device Reboot** and click the **Automatic Reboot** tab.

Step 2 Select the **Enable Auto Reboot** check box.

Step 3 Set **Reboot Mode** to **At intervals**.

Step 4 Set **Interval** to a value in minutes, such as **1440**.

Step 5 Click **Save**.

Manual Reboot **Automatic Reboot**

Enable Auto Reboot

Reboot Mode

Interval minute (Range: 10 - 7200)

Save

Restore

Help

--End

Rebooting the AP at specified time

Configuration procedure:

- Step 1** Choose **Tools > Device Reboot** and click the **Automatic Reboot** tab.
- Step 2** Select the **Enable Auto Reboot** check box.
- Step 3** Set **Reboot Mode** to **At specified time**.
- Step 4** Select the day or days when the AP reboots.
- Step 5** Set the time when the AP reboots, such as **23:59**.
- Step 6** Click **Save**.

Manual Reboot **Automatic Reboot**

Enable Auto Reboot

Reboot Mode

Date Every day Mon. Tue. Wed. Thur. Fri. Sat.
 Sun.

Time Example: 3:00

Save

Restore

Help

--End

9.8 LED Control

This function enables you to turn on/off the LED indicator of the AP. By default, the LED indicator is turned on.

Procedure for turning off the LED indicator:

Step 1 Choose **Tools > LED Control**.

Step 2 Click **Turn Off All Indicators**.

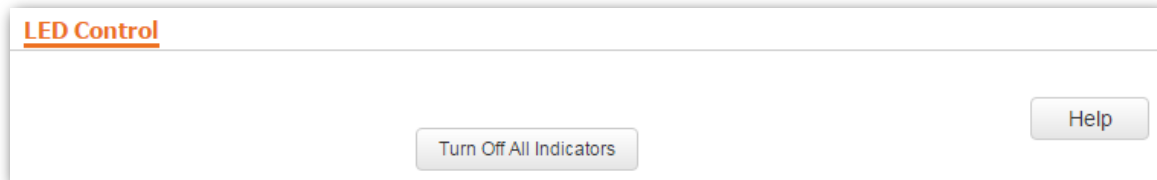

--End

Procedure for turning on the LED indicator:

Step 1 Choose **Tools > LED Control**.

Step 2 Click **Turn On All Indicators**.

--End

Appendixes

A.1 FAQ

Q1. I cannot access the web UI of the AP after entering 192.168.0.254. What should I do?

A1: Check the following items:

- Verify that the IP address of your computer is 192.168.0.X (X: 2~253).
- Clear the cache of your web browser or replace the web browser, and try login again.
- Disable the firewall of your computer or replace the computer, and try login again.
- If two or more APs are connected to your network without an AP controller, connect one of the APs to your network and change the IP address of the AP. Repeat this procedure to change the IP addresses of the other APs.
- The AP may be being managed by an AP controller and therefore its IP address is no longer 192.168.0.254. In that case, log in to the web UI of the AP controller to view the new IP address of the AP, and log in to the AP using the new IP address.
- If you have manually changed the IP address of the AP, change the IP address of your computer to another IP address that belongs to the same network segment as the new IP address of the AP and log in again using the new IP address of the AP.
- If the problem persists, restore the factory settings of the AP and try login again.

Q2. My wireless AP controller cannot find the AP. What should I do?

A2. Check the following items:

- Verify that the devices are connected properly and the AP has started.
- If VLANs have been defined on your network, verify that the corresponding VLAN has been added to your AP controller.
- Restart the AP or restore the factory settings of the AP, and try scanning the AP again.

Q3. Can I log in to the web UI of the AP to configure the AP after using an AC controller to manage the AP?

A3. Yes. You are recommended to change the user name and password of the administrator account (see [9.5 Account](#)) if you use an AC to manage the AP. This improves network security.

For more technical assistance, visit our website at <http://www.tendacn.com> or send your question to support@tenda.cn. We will help you resolve your problem as soon as possible.

A.2 Setting the IP Address of Your Computer

Example: Windows 7

- Step 1** Choose **Start > Control Panel**, click **Network and Internet**, click **Network and Sharing Center**, and click **Change adapter settings**.
- Step 2** Right-click **Local Area Connection** and choose **Properties**. Select **Internet Protocol Version 4 (TCP/IPv4)** and click **Properties**.

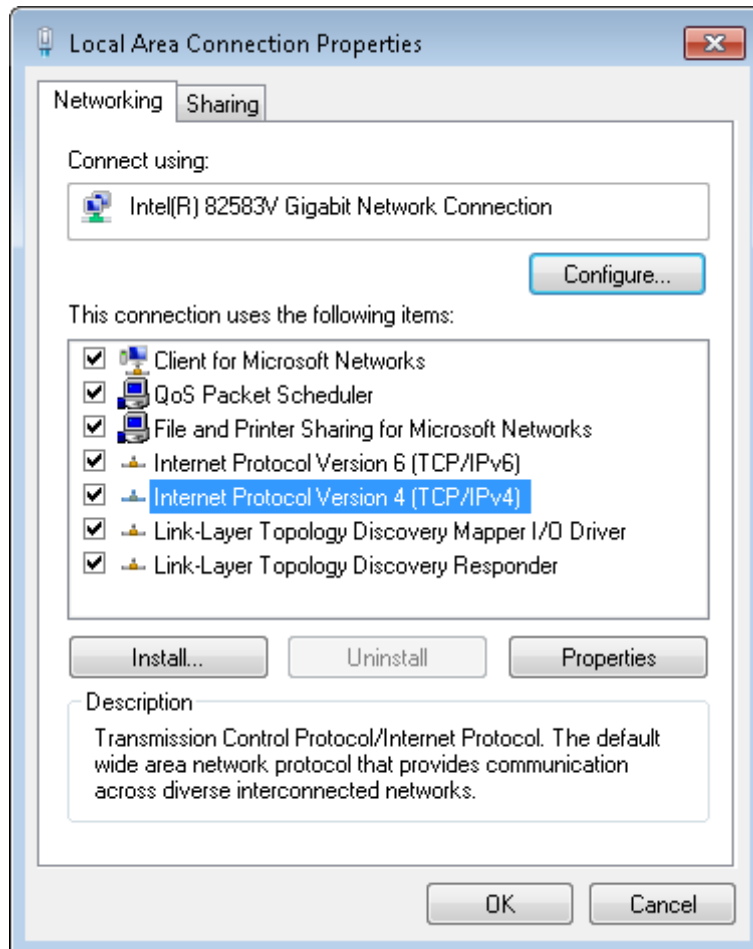

- Step 3** Select **Use the following IP address**. Set **IP address** to an IP address that is different from the IP address of the LAN port of the AP but belongs to the same network segment as the IP address of the LAN port of the AP. Set **Subnet mask** to **255.255.255.0**. Click **OK**.

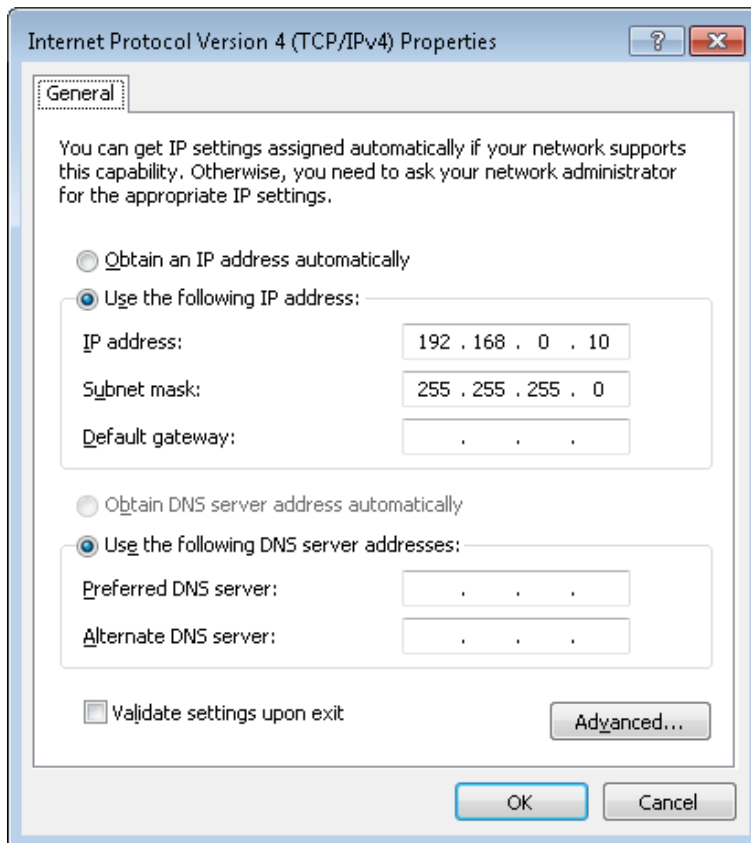

The **Local Area Connection Properties** dialog box appears.

Step 4 Click **OK**.

--End

A.3 Default Parameter Settings

The following table lists the factory settings of the AP.

Parameter		Default Value	
Login	IP address	192.168.0.254	
	User Name/Password	Administrator	admin/admin
		User	user/user
Quick Setup	Working Mode	AP Mode	
LAN Setup	IP Address Type	Static	
	IP Address (management IP address)	192.168.0.254	
	Subnet Mask	255.255.255.0	
	Gateway	192.168.0.1	
	Primary DNS Server	8.8.8.8	
	Secondary DNS Server	8.8.4.4	
	Device Name	<i>Model + Hardware version number, such as i9V2.0</i>	
DHCP Server	DHCP Server	Disable	
	Start IP	192.168.0.100	
	End IP	192.168.0.200	
	Lease Time	1 day	
	Subnet Mask	255.255.255.0	
	Gateway	192.168.0.1	
	Primary DNS Server	8.8.8.8	
	Secondary DNS Server (Optional)	8.8.4.4	
Wireless Basic	SSID	Supports 4 SSIDs. SSID is Tenda_XXXXXX, where XXXXXX indicates the last 6 characters in the MAC address specified on the label on the external surface of the AP - +3 The primary SSID is enabled, and others are disabled.	
	Broadcast SSID	Enable	
	Isolate Client	Disable	

Parameter		Default Value
	WMF	Disable
	Max. Number of Clients	32
	Chinese SSID Encoding	UTF-8
	Security Mode	None
RF	Wireless network	Enable
	Network Mode	11b/g/n
	Channel	Auto
	Channel Bandwidth	20/40 MHz
	Extension Channel	Auto
	Lock Channel	Enable
	Isolate SSID	Disable
	APSD	Disable
	Client Timeout Interval	5 minutes
Wireless Advanced	Beacon Interval	100 ms
	Fragment Threshold	2346
	RTS Threshold	2347
	DTIM Interval	1
	Min. RSSI Threshold	Disable
	Interference mitigation	2
	Transmit Power	20 dBm
	Lock Power	Enable
	Preamble	Long Preamble
WMM	WMM function	Enable
	WMM Optimization Mode	Optimized For Capacity (Concurrent Users >=10)
Wireless Access Control		Disable
QVLAN	QVLAN function	Disable
	PVID	1
	Management VLAN	1

Parameter		Default Value	
	2.4 GHz SSID VLAN ID	1000	
SNMP	SNMP Agent	Disable	
	SNMP Parameters	Administrator Name	Administrator
		AP Name	<i>Model + Hardware version number, such as i9V2.0</i>
		Location	ShenZhen
		Read Community	public
Read/Write Community	private		
Tools	System Time	Synchronize with internet Time	Enable
		Time Zone	(GMT+08:00) Beijing, Chongqing, Hong Kong, Urumqi, Taipei
	Login Timeout	5 minutes	
	Number of Logs Displayed	150	
	Automatic Reboot	Disable	
	LED Control	LED indicators turn on	