



Astris 3K/5K/6K

Installation Manual
(Hardware)

SIN110030001ATCU0B - Astris 3K/1P1T1
SIN110030001ATCU1B - Astris 3K/1P1T1
SIN120040002ATCU0B - Astris 4K/1P2T2
SIN120050002ATCU0B - Astris 5K/1P2T2
SIN120060002ATCU0B - Astris 6K/1P2T2

Manual de instalare
(Hardware)



316.06.23.0

Contents

Safety	2
1.1 Personnel Safety	2
1.2 PV Inverter Protection	3
1.3 Installation Safety	3
1.4 Electrical Connections	3
1.5 Operating and Commissioning	4
1.6 Maintenance	4
1.7 Additional Information	5
Overview of the Inverter	5
2.1 Functional Models	5
2.2 Network Application	6
2.3 Outline and Dimensions	6
2.4 Working Process	8
2.5 Working Modes	9
Storage	10
Installation	11
4.1 Checking the Outer Packing	11
4.2 Moving the inverter	12
4.3 Identify the PV Inverter	12
4.4 Installation Requirements	13
4.5 Installing a Rear Panel	17
4.6 Installing the inverter	20
Electrical Connections	21
5.1 Connecting Protection Ground (PGND) Cables	21
5.2 Connecting AC Output Cables	23
5.3 Connecting the PV Strings	26
5.4 Connecting Communication Cables	31
5.5 Power limit (optional)	32
5.6 Installation Verification	34
System Operation	35
6.1 Powering ON the Inverter	35
6.2 Powering OFF the Inverter	35
User Interface	36
7.1 HMI specification definition	37
7.2 LCD automatic-page-turning display	38

Maintenance	39
8.1 Routine Maintenance	39
8.2 Inverter Troubleshooting	41
8.3 Removing the Inverter	43
Disposal of the Inverter	44

Forward

Please read this manual before using the product.

This user manual introduces the inverter in terms of its installation, electrical connections, operation, commissioning, maintenance, and troubleshooting. Please read through the manual carefully before installing and using the inverter, and keep the manual well for future reference.

Application Model

Grid-tied PV string inverter

- 3K/5K/6K

Applicable Personnel







This user manual is intended for photovoltaic (PV) inverter operating personnel and qualified electrical technicians.

NOTE!

This user manual is subject to change without prior notice.

Symbol Conventions

Safety symbols used in this manual, which highlight potential safety risks and important safety information, are listed as follows:

Symbol	Description
 DANGER	Indicates an imminently hazardous situation which, if not correctly followed, will result in serious injury or death.
 WARNING	Indicates a potentially hazardous situation which, if not correctly followed, could result in serious injury or death.
 CAUTION	Indicates a potentially hazardous situation which, if not correctly followed, could result in moderate or minor injury.
 NOTICE	Indicates a potentially hazardous situation which, if not correctly followed, could result in equipment failure, or property damage.
 NOTE	Calls attention to important information, best practices and tips: supplement additional safety instructions for your better use of the PV inverter to reduce the waste of your resource.
 REFER	Refer to documentation (Remind operators to refer to the documentation shipped with the inverter).

1 Safety

Before beginning your journey, please read these safety precautions in User Manual carefully.

1.1 Personnel Safety

- The PV inverter must be installed, electronically connected, operated and maintained through specially trained technician;
- The qualified technician must be familiar with the safety regulations of electrical system working process of PV power generation system, and standards of local power grid;
- The technician must read through this User Manual carefully and master it before any operation.

1.2 PV Inverter Protection

NOTE!

As soon as receiving the PV inverter, please check if it is damaged during its transportation. If yes, please contact your dealer immediately.

- a. Do not tamper with any warning signs on the inverter enclosure because these signs contain important information about safe operation.
- b. Do not remove or damage the nameplate on the inverter's enclosure because it contains important product information.

1.3 Installation Safety

NOTE!

Please read the User Manual carefully before installing the PV inverter; warranty or liability will be void from our company if damage is caused by installation faults.

- a. Ensure there is no electrical connections around ports of the PV inverter before installing;
- b. Adequate ventilation must be provided for inverter installation location. Mount the inverter in vertical direction, and ensure that no object is put on the heat sink affecting the cooling. (For details, refer to Chapter 4 Installation).

1.4 Electrical Connections



DANGER

Before installing the inverter, check all electrical ports to ensure no damage and no short circuit. Otherwise personal casualty and/or fire will occur.

- a. Input terminals of the PV inverter apply only to input terminals of PV String; do not connect any other DC source to the input terminals.
- b. Before connecting PV modules, ensure that its voltage is within the safe range; when exposed to any sunlight, PV modules can generate high voltage.
- c. All electrical connections must meet the electrical standards of the country or region.

d. Cables used in electrical connections must be well fixed, good insulation, and with appropriate specification.

1.5 Operating and Commissioning

DANGER

While the inverter operating, high voltage can lead to an electrical shock hazard, and even cause personal casualties. Therefore, operate the PV inverter strictly according to the safety precautions in the user manual.

WARNING

When the photovoltaic array is exposed to light, it supplies a DC voltage to the PCE.

- a. Before getting the permission of electrical power authority in the country/region, the grid-tied PV inverter cannot start generate power.
- b. Follow the procedures of commissioning described in the user manual when commissioning the PV inverter.
- c. Do not touch any other parts'surface except the DC switch when the PV inverter is operating; its partial parts will be extremely hot and can cause burns.

1.6 Maintenance

DANGER

Power OFF all electrical terminals before the inverter maintenance; strictly comply with the safety precautions in this document when operating the inverter.

- a. For personal safety, maintenance personnel must wear appropriate personal protective equipment (like insulation gloves and protective shoes) for the inverter maintenance.

- b. Place temporary warning signs or erect fences to prevent unauthorized access to the maintenance site.
- c. Follow the procedures of maintenance stipulated in the manual strictly.
- d. Check the relevant safety and performance of the inverter; rectify any faults that may compromise the inverter security performance before restarting the inverter.

1.7 Additional Information

NOTE!

To avoid any other unforeseeable risk, contact your dealer immediately, if there is any issue found during operation.

2 Overview of the Inverter

This chapter introduces the inverter and describes its functional model, network application, appearance, dimensions, and working process etc.

2.1 Functional Models

2.1.1 Function

This series is a single-phase grid-tied PV string inverter (transformer less) that converts the DC power generated by PV strings into AC power and feeds the power into power grid.



WARNING

The inverter is transformerless. Add an isolation transformer before grounding the positive/ negative terminal of PV modules (like Thin Film module) for operation.



WARNING

Do not connect PV modules in parallel to several PV inverters for operation.

2.1.2 Model Description

Figure 2.1 shows a model number of the inverter, using 3K and 5K/6K as an example.

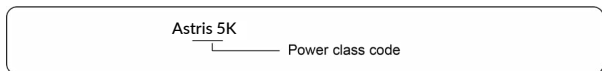

Figure 2.1 Model number descriptions

2.2 Network Application

2.2.1 Grid-tied PV Power Systems

The series applies to grid-tied PV power systems for outdoor power stations. Typically, a grid-tied PV power system consists of PV modules, grid-tied inverters, AC distribution units, and low-voltage power grid, as shown in Figure 2.2.

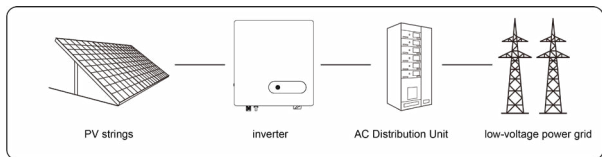

Figure 2.2 a low-voltage grid-tied PV power system

2.3 Outline and Dimensions

2.3.1 Outline

Figures 2.3 to 2.7 show the outline of the inverters as follows:

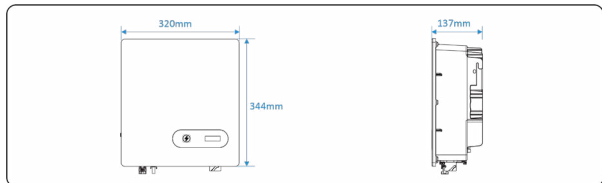

Figure 2.3 - 3K PV Inverter with Single MPPT Input (unit: mm)

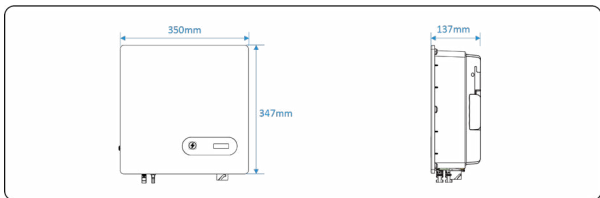

Figure 2.4 - 5K/6K PV Inverter with Dual MPPT Input (unit: mm)

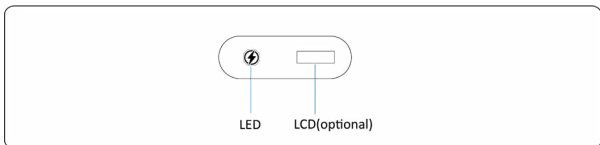

Figure 2.5 The front view and amplification effect of LED indicator area

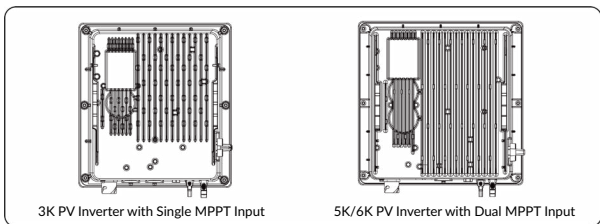

Figure 2.6 The rear view of this series of inverter

1. PV input connectors
2. COM2(RS-485/meter/CT/DI)
3. COM1(WIFI/GPRS/Ethernet/ RS-485)
4. AC output connector
5. External protect
6. Vent valve
7. DC isola

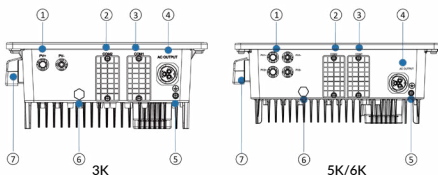

Figure 2.7 The bottom view of this series of inverter

2.4 Working Process

2.4.1 Basic principle Description

The 5K/6K PV Inverter with Dual MPPT Input receives input from two strings of PV panel (3K PV Inverter with Single MPPT Input receives input from only one string of PV panel). Then the inputs are grouped into two independent MPPT routes inside the inverter to track the maximum power point of the PV panel. The two MPPT power is then converted into DC Bus, then the DC power is converted to AC power through an inverter circuit. Finally the AC power is fed to the Power grid. EMI filter is used on both the DC and AC sides to reduce the electromagnetic inference; Surge protection is supported on AC side.

2.4.2 Circuit Diagrams

Figure 2.8 shows the circuit diagram for the 3K PV Inverter with Single MPPT Input:

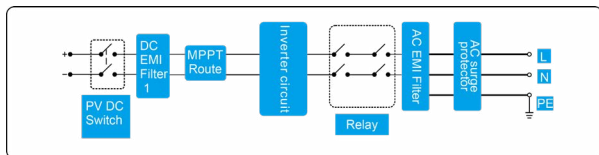

Figure 2.8 circuit diagram

Figure 2.9 shows the circuit diagram for the 5K/6K Inverter with Dual MPPT Input:

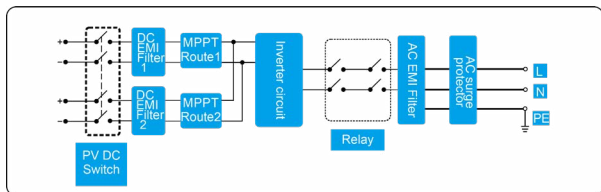

Figure 2.9 circuit diagram

2.5 Working Modes

Three working modes of the inverter are shown as follows: standby, operating, and shutdown.

Table 2.1 shows the conditions for the inverter to switch between working modes.

Modes	Description
Standby	<p>The PV inverter enters the standby mode when</p> <ul style="list-style-type: none"> >the input voltage of PV Strings can enable auxiliary power supply to run, but cannot meet the inverter operation requirements. >the input voltage of PV Strings can meet the inverter to-start requirements, but cannot meet its minimum power requirements.
Operating	<p>When the PV inverter is grid-tied and generates electricity, it</p> <ul style="list-style-type: none"> > tracks the maximum power point to maximize the PV String output. > converts DC power from PV strings into AC power and feeds the power to the power grid. <p>The PV inverter will enter to the shutdown mode if detecting a fault or a shutdown command.</p>
Shutdown	<p>The PV inverter switches from standby or operating mode to shutdown mode if detecting a fault or a shutdown command.</p> <p>The inverter switches from shutdown mode to standby mode if receiving a Startup command or detecting that a fault is rectified.</p>

Table 2.1 Working modes description

NOTE!

instructions: if the equipment is used in a manner not specified by the manufacturer, the protection provided by the equipment may be impaired.

3 Storage

This chapter describes the storage requirements for the inverter.

The following storage instructions apply if the PV inverter will not be deployed immediately:

- > Do not unpack the inverter (put desiccant in the original box if the PV inverter is unpacked).
- > Store the PV inverter at a temperature range of -25°C to +60°C and with the relative humidity of 0% to 100% (no condensing).
- > The PV inverter should be stored in a clean and dry place and be protected from dust and water vapor corrosion.
- > 3K PV Inverter with Single MPPT Input a maximum of eight layers of inverters can be stacked, 5K/6K PV Inverter with Dual MPPT Input a maximum of six layers of inverters can be stacked.
- > Do not position the inverter at a front tilt, excessive back tilt, or side tilt, or upside down.
- > Conduct periodic inspection during storage. Replace the packing materials immediately if any rodent bites are found.
- > Ensure that qualified personnel inspect and test the inverter before use if it has been stored for a long time.

4 Installation

DANGER

Do not install the inverter on flammable building materials or in an area where flammable or explosive materials are stored.

CAUTION

Do not install the inverter in a place where personnel are likely to come into contact with its enclosure and heat sinks to avoid electrical shock/burn.

4.1 Checking the Outer Packing

- When receiving the inverter, check that the packing materials are intact.
- After unpacking, check that the deliverables are complete, intact, and consistent with your order list.
- Examine the PV inverter and its fittings for damage such as scraps and cracks.

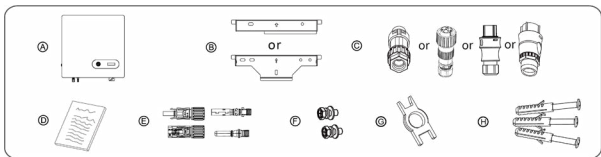

Items	Deliverables
A	The inverter
B	Rear panel
C	AC output connector
D	File package
E	DC terminal connector group
F	Screws
G	Removal tool for DC connector
H	Expansion screw group (reserved for tightening the support and rear panel)

Figures 4.1 The deliverables: The inverter and its fittings

NOTE!

If any damage mentioned above is found, contact the dealer immediately.

NOTE!

PV modules for non-isolated inverters. Non-isolated inverters shall be provided with installation instructions that require PV modules that have an IEC 61730 Class A rating. If the maximum AC mains operating voltage is higher than the PV array maximum system voltage then the instructions shall require PV modules that have a maximum system voltage rating based upon the AC mains voltage.

4.2 Moving the inverter

After checking the outer packing, move the PV inverter to the designated installation position horizontally. Hold the handles on both sides of the inverter, as shown in **Figure 4.2**.

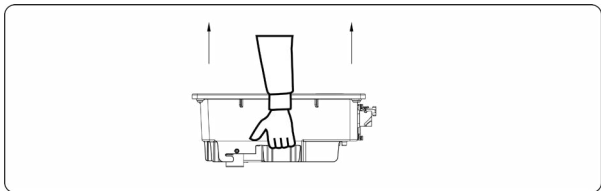

Figure 4.2 Moving the inverter



CAUTION





- >Do not place the PV inverter with its wiring terminals contacting the floor because the power ports and signal ports at the bottom of the device are not designed to support the weight of the inverter.
- >When placing the inverter on the floor horizontally, put foam or paper under to protect its enclosure.

4.3 Identify the PV Inverter

4.3.1 Nameplate

After moving the PV inverter from packing box, identify it by reading its nameplate labeled on the side of the inverter. The nameplate contains important product information: the model information, communications/technical specifications, and compliance symbols.

4.3.2 Compliance and Safety Symbols

Safety symbol	Description
	Electrical shock! There are residual voltages in the PV inverter. It needs 5 minutes to finish discharge.
	The PV inverter must not be touched when in operation. Its enclosure and heat sinks are extremely hot.
	Electrical shock! This part is charged. Only qualified and/or trained electrical technicians are allowed to perform operations on the inverter.
	If the inverter service life has expired, dispose it in accordance with local rules for disposal of electrical equipment waste. Do not dispose the PV inverter with household garbage.
	The PV inverter is compliant with TUV.

4.4 Installation Requirements

Applies to wall-mounting installation, as described below in detail.

4.4.1 Determining the Installation Position

Basic Requirements

- The inverter is protected to IP65 and can be installed indoors or outdoors.
- The installation method and position must be appropriate for the weight and dimensions of the inverter.
- Do not install the inverter in a place where personnel are likely to come into contact with its enclosure and heat sinks because these parts are extremely hot during operation.
- Do not install the inverter in an area that stores flammable or explosive materials.

Installation Environment Requirements

- The ambient temperature must be below 50°C to ensure the inverter's optimal operation and extend its service life.
- The inverter must be installed in a well ventilated environment to ensure good heat dissipation.
- The inverter must be free from direct exposure to sunlight, rain, and snow to extend its service life. It is recommended that the inverter be installed in a sheltered place. If no shelter is available, build an awning, as shown in **Figure 4.3**.

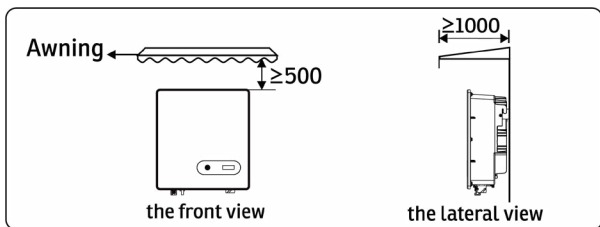

Figures 4.3 Installation environment with awning (unit: mm)

Carrier Requirements

- The carrier where the inverter is installed must be fire-proof. Do not install the inverter on flammable building materials.
- The wall must be solid enough to bear the weight of the inverter.
- Do not install the inverter on a wall made of gypsum boards or similar materials with weak sound insulation to avoid noise disturbance in a residential area.

Installation Space Requirements

- It is recommended that the inverter be installed at eye level to facilitate operation and maintenance.
- Reserve enough clearance around the inverter to ensure sufficient space for installation and heat dissipation, as shown in **Figure 4.4**.

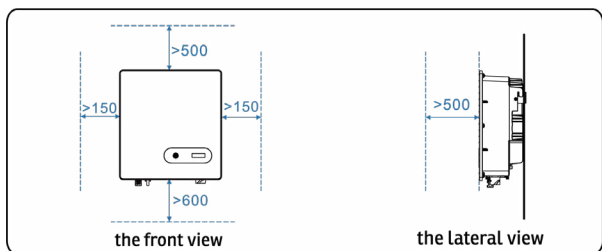

Figures 4.4 Installation Space Requirements (unit: mm)

c. When installing multiple inverter, install them along the same line (as shown in **Figure 4.5**) if sufficient space is available, and install them in triangle mode (as shown in **Figure 4.6**) or in stacked mode (as shown in **Figure 4.7**) if no sufficient space is available. The installation modes ensure sufficient space for installation and heat dissipation.

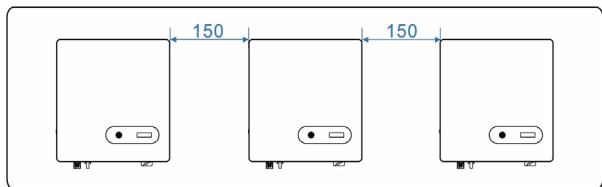

Figure 4.5 Installation along the same line (unit: mm)

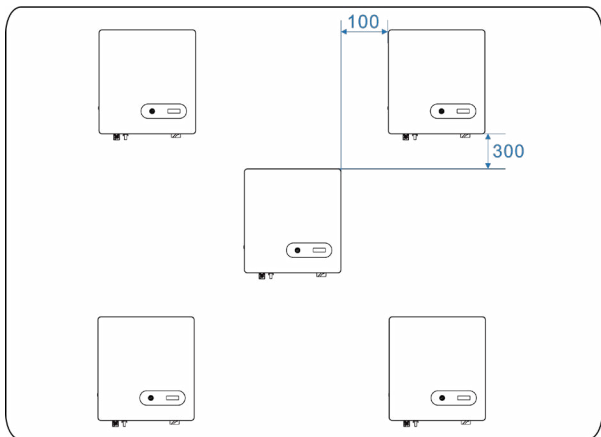

Figure 4.6 Installation in triangle mode (unit: mm)

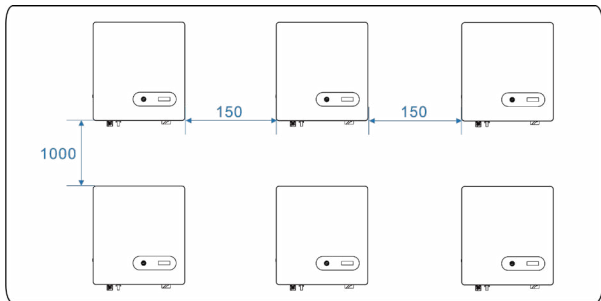

Figure 4.7 Installation in stacked mode (unit: mm)

NOTE!

The clearance between multiple inverters must be increased to ensure proper heat dissipation when they are installed in a hot area.

4.4.2 Installation Mode Requirements

Install the inverter upright or at a maximum back tilt of 15 degrees to facilitate heat dissipation. Some correct / wrong installation modes are shown in **Figures 4.8&4.9** below.

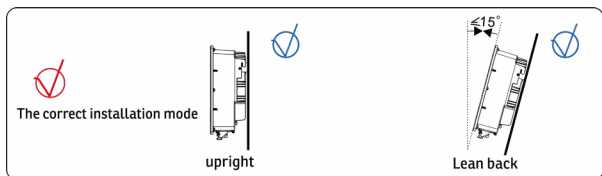

Figures 4.8 The correct installation mode

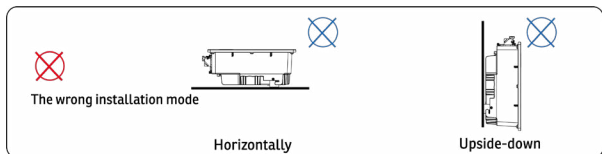

Figures 4.9 The wrong installation modes

NOTE!

The wrong installation will lead to failure of the inverter operation.

4.5 Installing a Rear Panel

Before installing the inverter, secure the rear panel to a wall.

Step 1 Move out the rear panel from the packing case.

Step 2 Determine the positions for drilling holes (as shown in **Figure 4.10**) using the rear panel.

NOTE!

The recommended 5K/6K inverter rear panel mounting combination is hole 1, 4 or 2, 3.

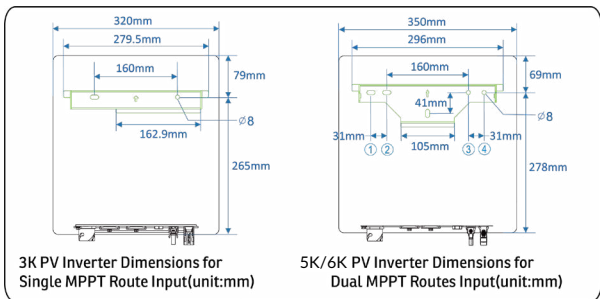

Figure 4.10 Determine the positions for drilling holes (unit: mm)

Step 3 Level the hole positions using a level gauge, and mark the hole positions using a marker (as shown in **Figure 4.11**).

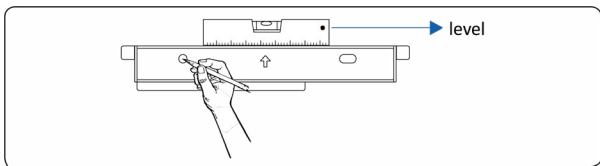

Figure 4.11 mark the hole positions using a marker

Step 4 Drill holes using a hammer drill and install expansion bolts, as shown in **Figure 4.12**.



DANGER

Before drilling the hole on the wall, ensure no damage on the electric wire and/or water pipe inside the wall.

- a. Drill a hole in a marked position to a depth of 60 mm using a hammer drill with a $\Phi 10$ mm bit.
- b. Partially tighten an expansion bolt, vertically insert it into the hole, and knock the expansion bolt completely into the hole using a rubber mallet.

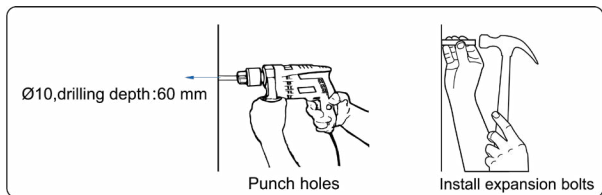

Figure 4.12 Punch holes and install expansion (unit: mm)

Step 5 Align the rear panel with the holes, insert expansion bolts into the holes through the real panel, and tighten the expansion bolts to a torque wrench (torque 2-2.5 N·m), as shown in **Figure 4.13**.

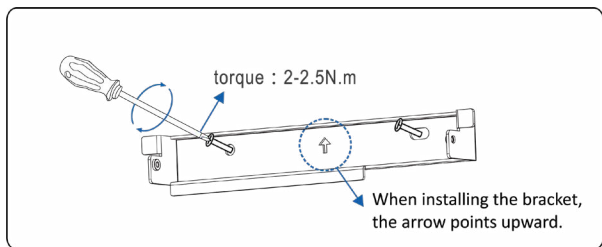

Figure 4.13 Installing the real panel

4.6 Installing the inverter

Follow below procedures:

Step 1 Hold the handles at both sides of the inverter and then lift and stand the inverter.

Step 2 Mount the inverter on the rear panel and keep them aligned with each other, as shown in **Figure 4.14**.

Step 3 Tighten the two hexagon screws at the both sides of the inverter to a torque of 1.2N.m and 3N.m respectively. Screw specs for 3K and 5K/6K are M4 and M6 respectively, as shown in **Figure 4.14**.

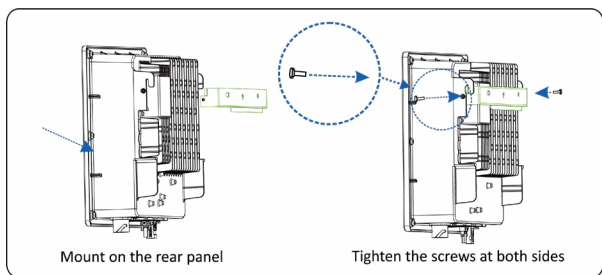

Figure 4.14 Securing the inverter

**DANGER**

Before performing any electrical connections, ensure that both DC and AC Switches are OFF. Otherwise, fatal injury can occur due to the high voltage caused from AC and DC cables.

5.1 Connecting Protection Ground (PGND) Cables

5.1.1 Preparation

The ground cable and OT terminals have been prepared.

- a. Ground cable: Outdoor copper-core cables with a cross sectional area of 4 mm or more are recommended.
- b. OT terminal: OT6~4.

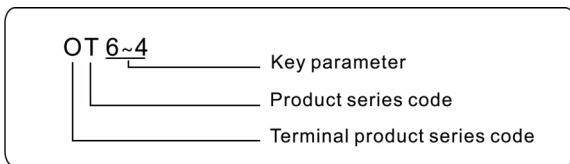

NOTE!

Good grounding for the inverter helps resist the impact of surge voltage and improve the EMI performance. Connect the PGND cable before connecting the AC power cables, DC power cables, and communication cables.

NOTE!

It is recommended that the ground cable be connected to a nearby ground position. For a system with multiple inverters connected in parallel, connect the ground points of all inverters to ensure equipotential connections.

5.1.2 Wiring Procedures

Step 1 Remove an appropriate length of the insulation layer from the PGND cable using a wire Stripper; the length is a little bit longer than that of OT terminal's crimping end by 2mm~3mm, as shown in **Figure 5.1**.

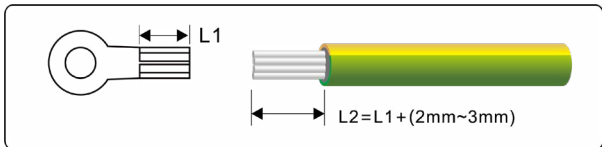

Figure 5.1 Stripped length (unit: mm)

Step 2 Insert the exposed core wires into the crimping areas of the OT terminal and crimp them using hydraulic pliers, as shown in **Figure 5.2**.

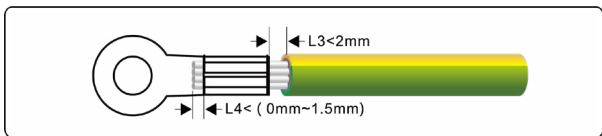

Figure 5.2 Crimping a cable (unit: mm)

Step 3 Remove the ground screws from the ground points, as shown in **Figure 5.3**.

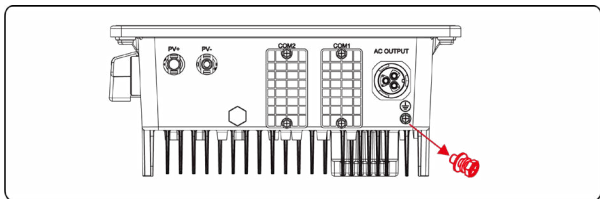

Figure 5.3 Crimping a cable (unit: mm)

Step 4 Secure the PGND cable (done by step 1 & 2) using the ground screw and tighten the screw using a socket wrench (torque 1.2 N-m), as shown in **Figure 5.4**.

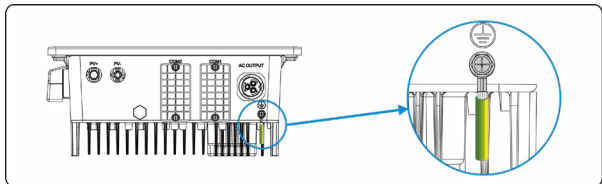

Figure 5.4 Secure the PGND cable

5.2 Connecting AC Output Cables

5.2.1 Preparation

The AC power cable and AC terminals have been prepared.

a. AC power cable: Outdoor copper-core cables are recommended. **Table 5.1** describes the specifications.

Inverter Model	Cable type	Cross-sectional Area(mm ²)		Cable Outer Diameter mm	
		Range	Recommended Value	Range	Recommended Value
3K	outdoor cable	4~6	4	10~14	14
5K/6K	outdoor cable		6		

Table 5.1 AC output cable specifications

b. The recommended specifications of circuit breaker are shown in the table below.

Inverter Model	Recommended Value
3K	25A
5K	32A
6K	40A

Table 5.2 Circuit breaker specifications



WARNING





An independent circuit breaker must be installed on the AC side of each inverter to ensure that the inverter can be safely disconnected from the power grid.



WARNING

Do not connect loads between the AC output terminals of the inverter and circuit breaker.

5.2.2 Procedure of Connecting AC Cables

 NOTE	There are four types of AC terminals in use (choose one from four). Please refer to the real object in the deliverables.		
 in usual	 optional	 optional	 optional

Step 1 It is recommended to use outdoor dedicated cables with multiple copper cores.

Remove an appropriate length of the jacket and insulation layer from the AC output cable using a wire stripper.

Step 2 Lead the AC cable through the rubber nut, seal and so on. Please refer to the following picture **number 2** below.

Step 3 Tighten three screws and ensure each screw cap does not exceed the surface, then install AC connector as shown picture **number 3-A** below.

Step 4 Plug the AC connector into the inverter.

NOTE!

There are four types of AC terminals. Please refer to the object in the delivery. **Type A** is in usual. Whether you use type **3-A**, **3-B/C/D**, tighten the waterproof nut to avoid loosening. Take **type 3-A** as example in the following steps.

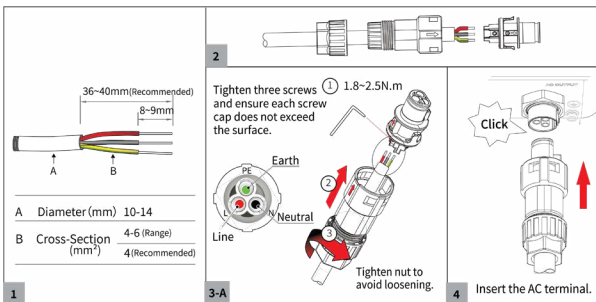

The wiring process of **type B**, **type C**, **type D** are shown as below.

Note: Whether you use type A, B, C or D, tighten the waterproof nut to avoid loosening.

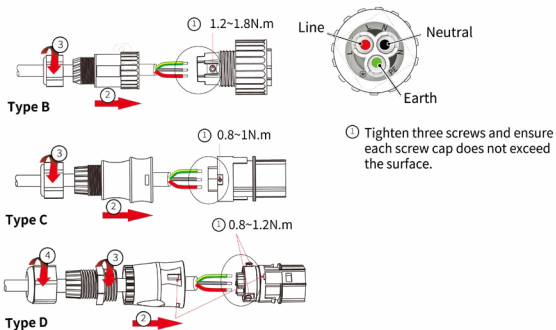

3-B/C/D

NOTE!

Ground, neutral, and line wires must correspond to G, N, and L terminals of AC connectors respectively. Otherwise, the faulty connection will lead to the inverter performance failure.

Step 5 After the AC terminal is connected, Install **protection sleeve (optional)** as shown in picture **number 5** below.

When you choose **type B**, the protection sleeve is **optional**.

Step 5 is only applicable to **type B** AC terminal when equipped with protection sleeve.

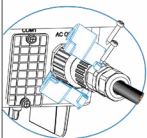

After the **type B** terminal is connected, install protection sleeve on the connection position, and tighten the screws to prevent the terminals from slipping off.

5

5.3 Connecting the PV Strings

DANGER

PV Strings connection requires the following prerequisites; otherwise, an electrical shock can occur.

PV modules generate electric energy when exposed to sunlight and can create an electrical shock hazard. Therefore, when connecting the PV modules, shield them with opaque cloth.

Before connecting DC input power cables, ensure that the voltage on the DC side is within the safe range and that the DC SWITCH on the inverter is OFF. Otherwise, high voltage may result in electric shock.

When the inverter is grid-tied, it is not allowed to maintain DC input power cables, such as connecting or disconnecting a string or a module in a string. Only after the inverter enters in shutdown mode, maintenance of DC input power cables is allowed.

WARNING

Grounding of the PV Strings requires the following prerequisites; otherwise, a fire can occur.

PV modules connected in series in each PV string must be of the same specifications.

The maximum open-circuit voltage of each PV string must be always lower than or equal to its permitted range.

The maximum short circuit current of each PV string must be always lower than or equal to its permitted range.

The positive and negative terminals of PV modules must be connected to the positive and negative DC input terminals of the inverter respectively. negative DC input terminals of the inverter respectively.

During the installation of PV strings and the inverter, the positive or negative terminals of PV strings cannot be connected with short circuit.

5.3.1 Preparation

Route collecting for the installation of PV strings and inverter:

Inverter Model	Number of Input Route
3K	Connected to route 1
5K/6K	Connected to route 2

PV Strings DC input cable and connectors have been prepared; Table 5.2 lists the recommended outdoor copper-core DC input cable specifications.

Inverter model	Cable Type	Cross-sectional Area(mm ²)		Cable OuterDiameter(mm)
		Range	Recommended Value	Range
3K	Common PV cables in the industry (model:PV1-F)	4~6	4	5~8
5K/6K				

Table 5.3 Recommended DC input cable recommended specifications

Connectors of PV Strings: Positive and negative DC input connectors are used, as shown in **Figure 5.8** and **Figure 5.9**.

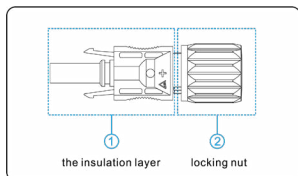

Figure 5.8 Positive connector compositions

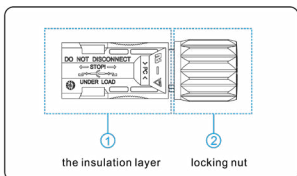

Figure 5.9 Negative connector compositions

NOTE!

Positive and negative metal connectors are packed with positive and negative connectors respectively when shipped out. After unpacking, keep the positive and negative ones separate to avoid confusion.

Procedures of connecting the PV Strings

Step 1 Remove an appropriate length of the insulation layer from the positive and negative power cables using a wire stripper, as shown in below Figure.

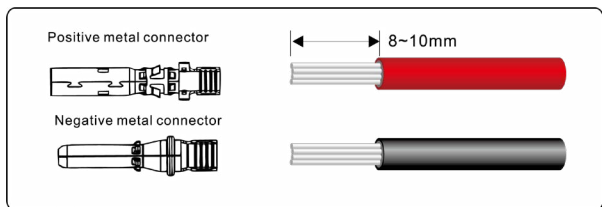

Figure 5.10 Removing insulation layer for DC cable (unit: mm)

Step 2 Insert the exposed areas of the positive and negative power cables into the metal terminals of the positive and negative connectors respectively and crimp them using a crimping tool, as shown in **Figure 5.11**.

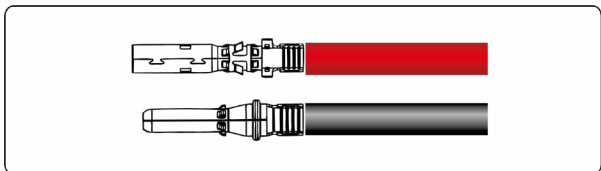

Figure 5.11 Crimping a metal connector

Step 3 Insert the crimped positive and negative power cables into the corresponding positive and negative connectors until a “click” sound is heard, as shown in **Figure 5.12**.

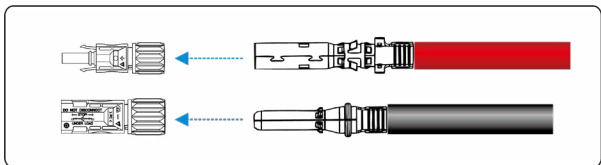

Figure 5.12 Connecting positive and negative connectors

Step 4 Tighten the locking nuts on the positive and negative connectors using a removal wrench, as shown in **Figure 5.13**.

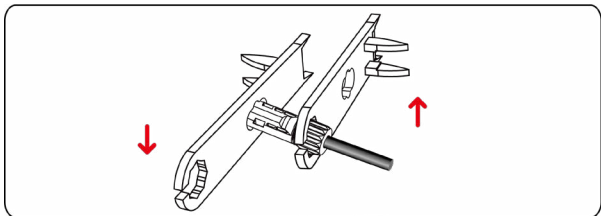

Figure 5.13 Locking connectors

Step 5 Measure the voltage of every route Strings using a multimeter. Ensure that the polarities of the DC input power cables are correct, as shown in **Figure 5.14**.

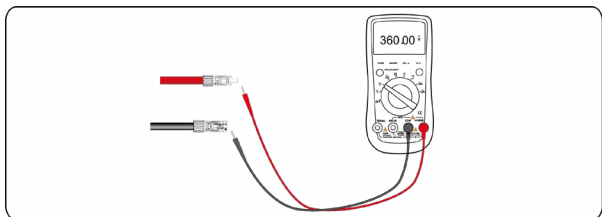

Figure 5.14 Checking the voltage of every route Strings

Step 6 Insert the positive and negative connectors into their corresponding terminals of the inverter until a “click” sound is heard, as shown in **Figure 5.15**.

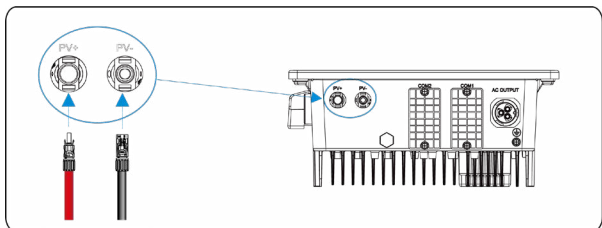

Figure 5.15 Connecting to the inverter

Step 7 After connecting the PV strings, ensure that all connectors are in position by checking for resistance when a slight pull is applied.

5.4 Connecting Communication Cables

5.4.1 Communication Mode Description

You can use the following communication modes to implement communication: Bluetooth, WIFI, GPRS and RS485 all of which are described as follows.

Bluetooth Module

You can turn on the Bluetooth function of the mobile phone, and set parameters and monitor data of the inverter through the mobile APP. For details about operation, refer to APP User Manual.

WIFI & GPRS & RS485 Modules

Following figure show inverter's interface to connect WIFI, GPRS and RS485 accessory, please refer user manual of accessory for connecting method and its setting.

Module	Function description
WIFI	WIFI module implements communication with Cloud server through wireless network to monitor PV inverter's data status. For more details, refer to WIFI Product Application Manual.
GPRS	GPRS module communicates with Cloud server through a mobile phone to monitor PV inverter's data status. For more details, refer to GPRS Product Application Manual.
RS485	RS485 switching module monitors PV inverter's data status through collecting and uploading data to Cloud server. For more details, refer to RS485 switching Product Application Manual.
NOTE	You can choose and buy WIFI/GPRS/RS485 communication modules from the company. The baud rate supported by RS485: 9600BPS

Table 5.4 WIFI & GPRS & RS485 Modules Description

5.5 Power limit (optional)

5.5.1 Wiring diagram of Inverter+CT

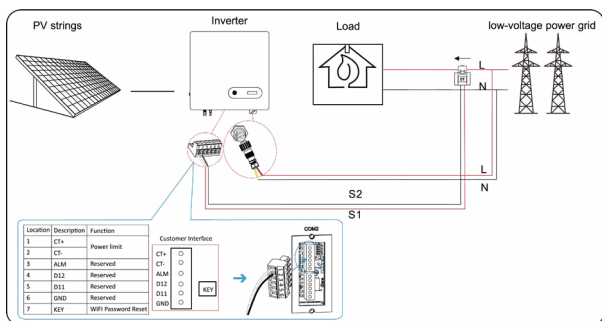

Figure 5.16 Wiring diagram of Inverter+CT

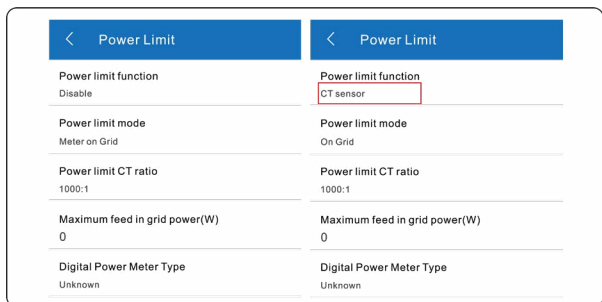

Figure 5.17 Settings via APP

- Power limit function set to “CT sensor”
- Set the CT position base on the meter installed on load or on grid
- Set maximum feed-in grid power if needed
- Set Power limit CT ratio

5.5.2 Wiring diagram of Inverter+Meter

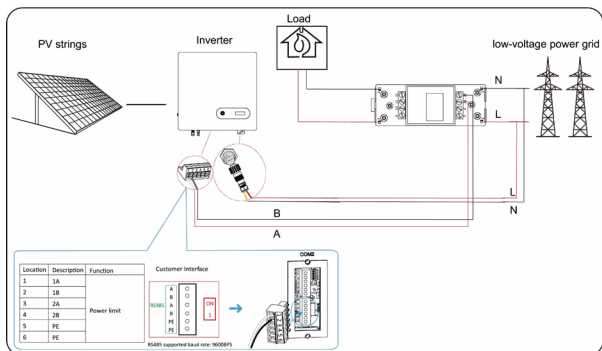

Figure 5.18 Wiring diagram of Inverter+Meter

Power Limit	Power Limit
Power limit function Disable	Power limit function Digital Power Meter
Power limit mode Meter on Grid	Power limit mode On Grid
Power limit CT ratio 1000:1	Power limit CT ratio 1000:1
Maximum feed in grid power(W) 0	Maximum feed in grid power(W) 0
Digital Power Meter Type Unknown	Digital Power Meter Type DDSU666

Figure 5.19 Settings via APP

- Set the “Power limit function” to “Digital Power Meter”
- Set the Digital Power Meter Type
- Set the meter position base on the meter installed on load or on grid
- Set maximum feed-in grid power if needed
- Set “Power limit CT ratio” only when using inverter+CT

When “Power limit function” is set to “Digital Power Meter”, the RS485 of inverter will change to a Host that will communicate with digital meter using Modbus-RTU protocol (9600 BPS, 8 data bit, 1 stop bit, no parity data format) through communication address 1. Please make sure that the meter is set to Modbus-RTU, 9600, 8-N-1 with address 1. For details of digital meter setting operation, please refer to the meter user manual.

5.6 Installation Verification

Check the following items after the inverter is installed according to **Table 5.4**.

1. No other objects are put on the PV inverter.
2. All screws, especially the screws used for electrical connections, are tightened
3. The PV inverter is installed correctly and securely.
4. Ground, AC, DC, and Communications cables are connected tightly/ correctly and securely.
5. Check and ensure there is no open circuit or short-circuits at AC and DC terminals using multimeter.
6. Waterproof connectors at AC terminals and RS485 ports are plugged with waterproof plugs tightly.
7. Covers at AC terminals are tightened.
8. Idle terminals are sealed.
9. All safety warning symbols are intact and complete on the inverter.

Table 5.5 Self-check items after installation

6.1 Powering ON the Inverter

Step 1: Switch ON the AC circuit breaker.

Step 2: If the inverter has a switch, turn the switch to “ON” state.

Step 3: Observe statuses of LED indicator lights on the inverter according to **Table 7.1**.

NOTE!

When LED status lights display the inverter has entered grid-connecting, it means the inverter is operating well. Any query during operating the PV inverter, call your dealer.

6.2 Powering OFF the Inverter

Step 1: Run a shutdown command on the mobile APP.

Step 2: Switch off the circuit breaker at AC terminal.

Step 3: If the inverter has a switch, turn the switch to “OFF” to observe.



WARNING

After the inverter is power off, the remaining electricity and heat may still cause electrical shock and body burns. Maintenance of the inverter shall begin ten minutes after the power-off.

7 User Interface

Display screen of inverter is composed of LED indicator (LCD is optional for some models). LED contains three color states, blue, green and red respectively. For more details, refer to **Table 7.1** HMI specification definition.

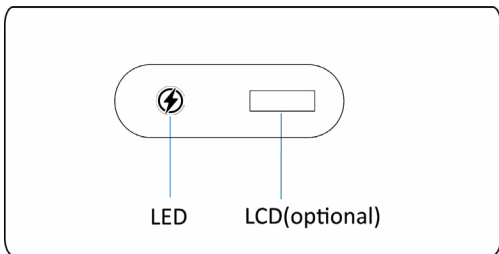

NOTE!

You can view & set data of the inverter through inverter APP. For details about operation, refer to APP User Manual. APP User Manual is available for free from www.nJoy.global website.

7.1 HMI specification definition

LED Indicator	Description	Status
Blue led	Standby	blink(slowly)
	Normal status	on
Green led	Limited power operation	on
Red led	Refer to the table below	
Warning Definition	LCD Display	Status
Grid over voltage	A0 Grid OV	Red led blink(slowly)
Grid under voltage	A1 Grid UV	Red led blink(slowly)
Grid absent	A2 Grid Loss	Red led blink(slowly)
Grid over frequency	A3 Grid OF	Red led blink(slowly)
Grid under frequency	A4 Grid UF	Red led blink(slowly)
PV over voltage	B0 PV OV	Red led blink(quickly)
Insulation resistance abnormal	B1 Imp abn	Red led blink(quickly)
Leakage current abnormal	B2 Lkge abn	Red led blink(quickly)
Control power abnormal	C0 Powerfail	Red led on
Arc fault	C1 Arc fault	Red led on
Dc bias current abnormal	C2 OP Dc OC	Red led on
Inverter relay abnormal	C3 RLY abn	Red led on
Inverter over temperature	C5 SYS OT	Red led on
Leakage current HCT abnormal	C6 LkgCT abn	Red led on
System fault	C7 SYS err	Red led on

Fan fault	C8 FAN lock	
DC link under voltage	C9 Bus UV	Red led on
DC link over voltage	CA Bus OV	Red led on
Internal Communications fault	CB COM err	Red led on
Software version incompatibility	CC FW Incomp	Red led on
EEPROM fault	CD EEP err	Red led on
Sampling inconsistency	CE Inconsis	Red led on
Boost circuit abnormal	CG Bst abn	Red led on
Remote off	CN RMT OFF	

Table 7.1 HMI specification definition

7.2 LCD automatic-page-turning display

Mode	Display content	Note
The LCD display interface of the inverter standby state is shown in the following sequence:	Astris 5K Ver 01.00.00	Model name Version
	Udc 360/360V Vac 220V	PV voltage AC voltage
	Today 80kWh Etot 8000kWh	Today Energy Total Energy
	A0 Grid OV B1 Imp abn	Warning
The LCD display interface for countdown of inverter gridconnected is shown in the right picture:	Starting 60s	Start counter down

<p>The LCD display interface of the inverter grid-connected state is shown in the figure on the right:</p>	<pre>Pac 5000W Today 50kWh</pre>	<p>Output power Today Energy</p>
	<pre>Etot 8000kWh Htot 80000hr</pre>	<p>Total Energy Total Hours</p>
	<pre>Vdc 350/350V Idc 8/8A</pre>	<p>PV voltage PV current</p>
	<pre>Vac 220V Iac 28A</pre>	<p>AC voltage AC current</p>
	<pre>08:00 2018-08-08</pre>	<p>hour:minute year/month/day</p>

Table 7.2 LCD automatic-page-turning display

8 Maintenance



WARNING

Before maintaining and commissioning inverter and its peripheral distribution unit, switch off all the charged terminals of the inverter and wait at least 10 minutes after the inverter is powered off.

8.1 Routine Maintenance

Check Item	Check Content	Maintain content	Maintenance Interval
inverter output status	Statistically maintain the status of electrical yield, and remotely monitor its abnormal status.	NA	Weekly

PV inverter cleaning	Check periodically and ensure that the heat sink is free from dust and blockage.	Clean periodically the heat sink.	yearly
PV inverter running status	Check that the inverter is not damaged or deformed. Check for normal sound emitted during inverter operation. Check and ensure that all inverter communications is running well.	If there is any abnormal phenomenon, replace the relevant parts.	monthly
PV inverter Electrical Connections	Check and ensure that AC, DC, and communication cables are securely connected; Check and ensure that PGND cables are securely connected; Check and ensure that cables are intact and free from aging;	If there is any abnormal phenomenon, replace the cable or re-connect it.	Semiannually

Table 8.1 Maintenance checklist and interval

8.2 Inverter Troubleshooting

When the inverter has an exception, its basic common warning and exception handling methods are shown in the table 8.2.

Alarm Name	Causes	Measures Recommended
Grid Over Voltage	The grid voltage exceeds its allowable range.	<ol style="list-style-type: none"> 1. If the alarm occurs accidentally, the power grid may be abnormal accidentally. No extra action is needed. 2. If the alarm occurs repeatedly, contact the local power station. After receiving approval of the local power bureau, revise the electrical protection parameters setting on the inverter through mobile APP. 3. If the alarm persists for a long time, check whether the AC circuit breaker/AC terminals is disconnected or not, or if the grid has a power outage.
Grid Under Voltage		
Over Frequency		
Under Frequency		
PV Over Voltage	PV modules input voltage exceeds the inverter's allowable range.	Check the number of PV modules and adjust it if need.
PV Under Voltage	PV modules input voltage is under the inverter's defaulted protection value.	<ol style="list-style-type: none"> 1. When sunlight intensity weakens, PV modules voltage decreases. No action is needed. 2. If such phenomena occur when sunlight intensity does not weaken, check if there is short circuit, open circuit etc. in the PV strings.
Insulation Resistance Abnormal	A short circuit exists between PV strings and protection ground. PV strings are installed in a long-term moist environment.	<ol style="list-style-type: none"> 1. Check the insulation resistance against the ground for the PV strings. If a short circuit has occurred, rectify the fault. 2. If the insulation resistance against the ground is less than the default value in a rainy environment, set Insulation resistance protection on APP.

Residual Current Abnormal	The insulation resistance against the ground at the input side decreases during the inverter operation, which causes excessively high residual current.	<ol style="list-style-type: none"> 1. If the alarm occurs accidentally, possibly the external circuits are abnormal accidentally. The inverter automatically recovers to the normal operating status after the fault is rectified. 2. If the alarm occurs repeatedly or lasts a long time, check whether the insulation resistance against the ground of PC strings is too low.
PV Strings Abnormal	PV strings have been obscured for a long time. PV strings are aging	<ol style="list-style-type: none"> 1. Check whether the PV string is obscured 2. If the PV string is clean and not obscured, check whether the PV modules are aging or deteriorated.
PV Strings Reverse	The cables of PV strings are connected reversely during the inverter installation.	Check whether the cables of PV strings are correctly connected. If they are connected reversely, reconnect the cables.
BUS Under Voltage	Abnormal internal energy control imbalance has been triggered by the PV Strings/grid sharp change of working conditions	<ol style="list-style-type: none"> 1. If the alarm occurs occasionally, the inverter can automatically recover to the normal operating status after the fault is rectified. 2. If the alarm occurs repeatedly, contact your dealer for technical support.
BUS Over Voltage		
Invert Module Fault		
BOOST Fault		
EEPROM Fault	EEPROM Component damaged	Replace the monitoring board.
Zero power generation and Yellow alarm light illuminating in remote monitor system	Communications outage	If modem or other data logger is used, please reboot it; if still does not work after rebooting, contact your dealer.

remote monitor displays zero power generation	Communications outage	If modem or other data logger is used, please reboot it; if still does not work after rebooting, contact your dealer.
remote monitor displays no output voltage	Output switch tripping	Check if DC switch is damaged, and if not, switch it to ON. If it still doesn't work, contact your dealer.
Inverter off grid	1. Power grid fault; 2. DC switch tripping	1. Wait till power is restored; 2. Turn DC switch to ON, and if DC switch trips a lot, contact your dealer.
Arc fault detection	Electrical Arcs	a. Check whether the circuit of the solar module is abnormal, including wire integrity, joint tightness. b. After the faults removal, turn off the AC/DC switch and start the inverter again, or click AFD Reset function on the APP page to eliminate the alarm.

Table 8.2 Common troubleshooting measures

NOTE!

If you cannot clear the preceding alarm according to the measures recommended, contact your dealer in a timely manner.

8.3 Removing the Inverter

Perform the following procedures to remove the inverter:

Step 1: Disconnect all cables from the inverter, including communications cables, DC input power cables, AC output power cables, and PGND cables.

NOTE!

When removing DC input connector, insert the removal wrench to the bayonet, press the wrench down, and take out the connector carefully.

Step 2: Remove the inverter from the rear panel.

Step 3: Remove the rear panel.



WARNING

Before removing DC input connector, double check and ensure DC input switch is turned OFF to avoid inverter damage and personal injury.

The PV inverter and its packing case are made from environment-friendly materials. If the inverter service life has expired, do NOT discard it with household garbage; dispose the inverter in accordance with local environmental laws and regulations.



Disposal of Old Electrical & Electronic Equipment

(Applicable in the European Union and other European countries with separate collection systems)

This symbol on the product or on its packaging indicates that this product shall not be treated as household waste.

Instead it shall be handed over to the applicable collection point for the recycling of electrical and electronic equipment.

By ensuring this product is disposed of correctly, you will help prevent potential negative consequences for the environment and human health, which could otherwise be caused by inappropriate waste handling of this product.

The recycling of materials will help to conserve natural resources.

Introducere	47
Masuri de siguranta	48
1.1 Masuri de siguranta pentru personalul autorizat	48
1.2 Masuri de precautie in operarea invertorului fotovoltaic	49
1.3 Precautiile de instalare	49
1.4 Conexiunea electrica	49
1.5 Operarea si aprobarea functionarii	50
1.6 Mentenanta	50
1.7 Informatii aditionale	51
Prezentarea invertorului	51
2.1 Model de functionare	51
2.2 Aplicatii	52
2.3 Dimensiuni si prezentare	52
2.4 Functionarea invertorului	54
2.5 Stari de functionare	55
Depozitare	56
Instalarea	57
4.1 Verificarea ambalajului	57
4.2 Manipularea invertorului	58
4.3 Identificarea tipului de invertor	58
4.4 Criterii de instalare	59
4.5 Instalarea panoului din spate	63
4.6 Instalarea invertorului propriu-zis	66
Conexiunile Electrice	67
5.1 Conectarea cablului de protectie impamantare (PGND)	67
5.2 Conectarea cablului de iesire curent alternativ (AC)	69
5.3 Conectarea sirurilor de panouri fotovoltaice	72
5.4 Conectarea cablurilor de comunicatie	77
5.5 Limitator de putere senzor	78
5.6 Verificari dupa instalare	80
Operarea sistemului	81
6.1 Pornirea invertorului	81
6.2 Oprirea invertorului	81
Interfata utilizatorului	82
7.1 Definirea informatiilor starilor HMI	83

7.2 Ecran LCD - Rasfoirea automata si semnificatia simbolurilor afisate	84
Mentenanata	85
8.1 Mentenanata periodica	85
8.2 Depanare invertor	86
8.3 Dezinstalarea invertorului	89
Colectarea invertorului pentru reciclare	90

Introducere

Va rugam sa parcurgeti manualul inainte de a instala si opera inverterul

Acest manual prezinta inverterul din punct de vedere al montarii, instalarii si conectarii electrice, functionarii, punerii in functiune, mentenantei si a depanarii. Va rugam sa parcurgeti manualul inainte de a instala si opera inverterul si pastrati-l pentru viitoare referinte.

Model

Inverter fotovoltaic on-grid

- 3K/5K/6K

Pentru personal autorizat







Acest manual de utilizare este dedicat pentru personal autorizat pentru instalari de invertoare on-grid si pentru electricieni calificati.

NOTIFICARE!

Acest manual de utilizare este supus modificărilor specifice fără o notificare prealabilă.

Simboluri de siguranta

Simbolurile utilizate in acest manual evidentiaza riscurile potientiale si informatiile care asigura siguranta operatorului, si sunt prezentate dupa cum urmeaza:

Simbol	Descriere
 PERICOL	Indica situatii periculoase iminente care incorect executate pot duce la raniri grave sau chiar la deces.
 AVERTISMENT	Indica situatii potential periculoase care incorect executate pot duce la raniri grave sau chiar la deces.
 ATENTIONARE	Indica situatii potential periculoase care incorect executate pot duce la raniri usoare si moderate.
 NOTIFICARE	Indica situatii potential periculoase care incorect executate pot duce la daune asupra echipamentului sau a proprietatii.
 BINE DE STIUT	Atrage atentia asupra informatiilor importante, a celor mai bune practici și sfaturi: completari a instructiunilor suplimentare de siguranta pentru o mai bună utilizare a inverterului fotovoltaic si pentru a reduce risipa de resurse.
 REFERINTA	Indica o referinta catre documentatia livrata cu echipamentul.

1 Masuri de siguranta

Inainte de a opera produsul, va rugam sa cititi cu atentie masurile de precautie prezentate in acest manual.

1.1 Masuri de siguranta pentru personalul autorizat

- Inverterul trebuie instalat, conectat, operat si verificat doar de tehnicieni/electricieni specializati.
- Tehnicianul specializat trebuie sa cunoasca reglementarile si masurile de siguranta in ceea ce priveste reseaua electrica, functionarea inverterului ongrid si standardele electrice locale.
- Tehnicianul specializat trebuie sa se familiarizeze cu informatiile prezentate in acest manual inainte de operarea inverterului.

1.2 Masuri de precautie in operarea invertorului fotovoltaic

NOTIFICARE!

Imediat dupa primirea invertorului verificati daca s-au produs daune in timpul transportului. Daca exista, contactati imediat unitatea de unde s-a achizitionat echipamentul.

- Nu ignorati avertismentele prezente pe carcasa invertor-ului deoarece ele contin informatii importante despre operarea lui in siguranta.
- Nu indepartati sau deteriorati informatiile de identificare ale invertorului deoarece contin informatii importante despre produs.

1.3 Precautii de instalare

NOTIFICARE!

Va rugam sa parcurgeti cu atentie manualul de utilizare inainte de a instala invertorul fotovoltaic; producatorul nu va fi raspunzator si nu va acorda garantie unui echipament deteriorat in timpul instalarii.

- Asigurati-va ca nu exista interferente electronice in jurul invertorului inainte de instalare.
- Un spatiu de ventilare adecvat trebuie avut in vedere la momentul instalarii. Montarea invertorului trebuie sa se faca in pozitie verticala si asigurati-va ca niciun obiect nu obstructioneaza radiatorul, si implicit racirea corespunzatoare. (Pentru detalii consultati Capitolul 4 al sectiunii Instalarea).

1.4 Conexiunea electrica



PERICOL

Inaintea instalarii invertorului, verificati sa nu existe deteriorari sau scurtcircuit la porturile electrice. In caz contrar exista riscul de vatamari corporale sau de incendiu.

- Terminalele de intrare ale invertorului se folosesc numai ca terminale de intrare de la Panourile Voltaice; nu conectați nicio altă sursă de curent continuu (DC) la terminalele de intrare.
- Inainte de conectarea panourilor la invertor, asigurati-va ca tensiunea panourilor e in limite normale, expuse la soare panourile vor genera tensiuni mari.
- Toate conexiunile electrice trebuie facute dupa standardele in vigoare din tara sau regiunea respectiva.

d. Cablurile utilizate la conexiuni trebuie bine fixate, bine izolate și cu specificațiile corecte.

1.5 Operarea și aprobarea funcționării

PERICOL

În timpul în care invertorul funcționează se generează tensiuni mari care pot fi periculoase și cauza electrocutări. Va sfătuim să urmați cu strictețe măsurile de precauție prezentate în acest manual.

AVERTISMENT

În momentul în care sistemul fotovoltaic este expus luminii va genera curent continuu (DC) către PCE.

- Invertorul fotovoltaic on-grid nu poate fi pus în funcțiune cu scopul de a genera electricitate înainte de a obține toate aprobările autorităților locale din țara sau regiunea unde se execută instalarea.
- Urmați procedura de aprobare pentru funcționare a invertorului așa cum este descrisă în manualul de utilizare.
- Nu atingeți nicio suprafață a invertorului atât timp când funcționează, cu excepția întrerupătorului DC. Suprafețele invertorului se pot încălzi foarte mult și pot cauza arsuri.

1.6 Mentenanța

PERICOL

Opriiți toate terminalele electrice înainte de mentenanța invertorului; respectați cu strictețe măsurile de siguranță din acest manual atunci când utilizați invertorul.

- Pentru o protecție eficientă a personalului autorizat pentru mentenanță, este necesar echipament de protecție compus din mănuși izolatoare și ghete de protecție.

b. In timpul mentenantei instalati temporar un perimetru de siguranta impotriva accesului neautorizat compus din semne distincte si garduri de protectie.

c. Urmati cu strictete procedura de mentenanta prezentata in acest manual.

d. Verificati toti parametrii de performanta si siguranta; corectati eventualele erori care poate impiedica functionarea eficienta si performanta a invertorului inainte de a-l reporni.

1.7 Informatii aditionale

NOTIFICARE!

Daca se identifica orice defect sau imperfectiune in functionare, va rugam sa contactati unitatea de unde ati achizitionat invertorul pentru a preveni orice risc viitor.

2 Prezentarea invertorului

Acest capitol prezinta caracteristicile invertorului, functionarea lui, aplicatia aferenta, dimensiuni, aspect etc.

2.1 Model de functionare

2.1.1 Tip invertor

Acest invertor este de tip on-grid, monofazat, fara transformator care prelucreaza curentul continuu (DC) generat de panourile fotovoltaice in curent alternativ (AC) catre aplicatiile conectate si catre reseaua electrica in caz de surplus.



AVERTISMENT

Acest invertor nu are transformator. Adaugati un transformator de izolare inainte de a lega impamantarea +/- panourilor fotovoltaice.



AVERTISMENT

Nu conectati panourile fotovoltaice in paralel la multiple invertoare.

2.1.2 Denumirea modelului de invertor

Figure 2.1 Schema de mai jos reprezinta felul in care este denumit modelul de invertor, utilizand 3K/5K/6K ca si exemplu.



Figura 2.1 Denumirea modelului

2.2 Aplicatii

2.2.1 Invertor fotovoltaic on grid

Aceasta documentatie se refera la invertoarele fotovoltaice care se conecteaza la rețeaua electrica publica. De obicei, aceste invertoare on-grid sunt formate din componentele prezentate in **Fig.2.2**

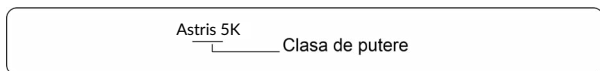

Figura 2.2 un sistem fotovoltaic de joasă tensiune legat la rețea

2.3 Dimensiuni si prezentare

2.3.1 Schita

Figurile de mai jos prezinta schita invertorului.

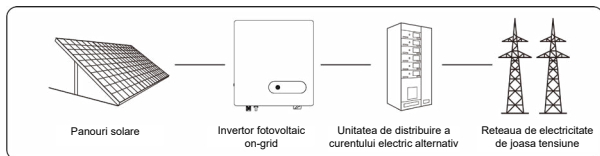

Figura 2.3 - Invertor fotovoltaic 3K cu o singură intrare MPPT(mm)



Figura 2.4 - Invertor fotovoltaic 5K/6K cu dubla intrare MPPT(mm)

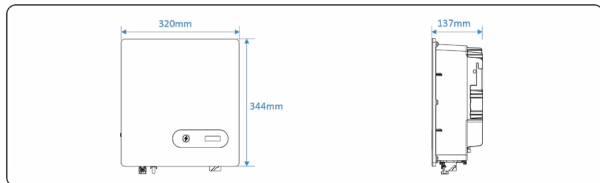

Figura 2.5 - Vedere din fata cu zona LED

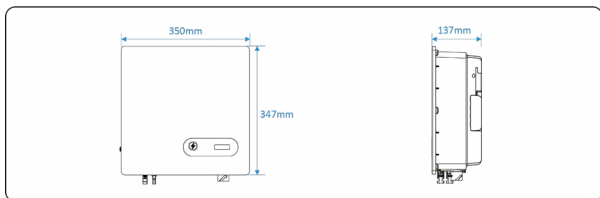

Figura 2.6 Vedere din spate

1. Conectori intrare panouri fotovoltaice
2. COM2(RS-485/meter/CT/DI)
3. COM1(WIFI/GPRS/Ethernet/ RS-485)
4. Conector iesire AC
5. Contactul exterior de impamantare
6. Valva de ventilatie
7. Intrerupator DC

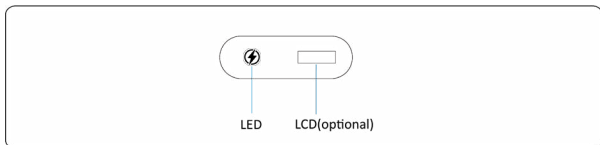

Figura 2.7 Vedere de jos

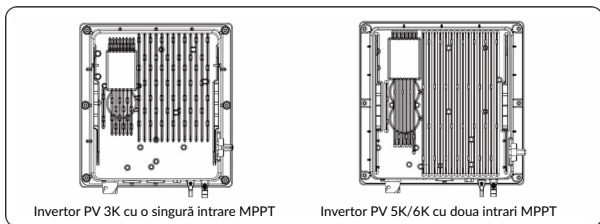
2.4 Functionarea invertorului

2.4.1 Principiul de functionare

Invertorul de 3K cu intrare singurara MPPT este compatibil cu 1 sir de panouri solare. Invertorul de 5K/6K cu intrare dubla MPPT este compatibil cu 2 siruri de panouri solare. I Apoi intrarile sunt grupate in 2 cai MPPT independente situate in interiorul invertorului pentru a urmari punctul puterii maxime a panoului PV. Energia electrica de pe aceste 2 cai e convertita in tensiune continua pe magistrala DC, apoi aceasta e convertita in curent alternativ de catre circuitul invertor. Un filtru EMI e folosit atat pe partea de curent continuu cat si pe partea de curent alternativ pt. a reduce interferenta electromagnetica. Protectia la supratensiunie e situata pe partea de curent alternativ.

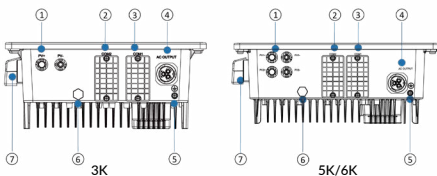
2.4.2 Schema circuit

Mai jos, este prezentata schema circuitului pentru invertorul de putere 3K cu intrare singurara MPPT.

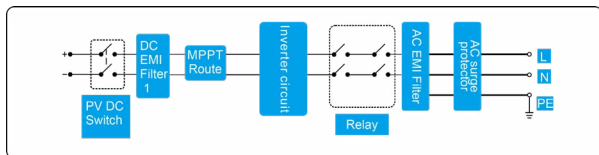

Figure 2.8 Schema circuit 3K

Mai jos, este prezentata schema circuitului pentru inverterul de putere 5K/6K cu intrare dubla MPPT.

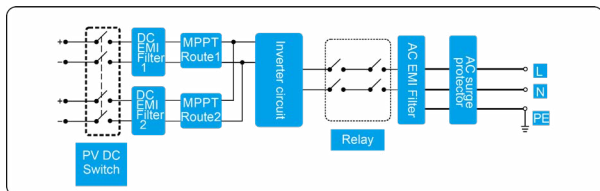

Figure 2.9 Schema circuit 5K/6K

2.5 Stari de functionare

Starile de functionare ale inverterului sunt: Stand-by (repaus), in functiune si oprit.

Tabelul de mai jos prezinta conditiile in care inverterul poate fi intr-una din starile specificate

Stare	Descriere
Stand-by/ Repaus	Inverterul adopta aceasta stare atunci cand: > Tensiunea de intrare de la panourile fotovoltaice poate alimenta circuitele auxiliare astfel incat sa functioneze, dar nu poate atinge parametrul minim de functionare al inverterului. > Tensiunea de intrare de la panourile fotovoltaice atinge parametru minim de functionare pentru a-l porni, dar nu poate mentine functionarea lui.
Pornit / In functiune	Atunci cand inverterul este on-grid si genereaza electricitate, el poate: > tine cont de punctul maxim de putere consumat pentru a maximiza performanta sirului de panouri fotovoltaice. > face conversia de la curent continuu (DC) la curent alternativ (AC) pentru a-l injecta in retea electrica.
Oprit	Inverterul va comuta in starea de oprit daca detecteaza o eroare sau o comanda de inchidere. Inverterul isi schimba starea din oprit in stand-by daca primeste o comanda de Pornire sau detecteaza ca o eroare a fost remediata.

Tabelul 2.1 Descrierea starile de functionare

NOTIFICARE!

Instructiune: daca echipamentul este folosit in mod diferit de cel specificat de producator, protectiile prevazute nu vor functiona eficient.

3 Depozitare

Acest capitol descrie conditiile pentru depozitarea invertorului.

Aceste instructiuni trebuie respectate in cazul in care invertorul nu este instalat imediat.

- > Nu desfaceti ambalajul original al invertorului (daca se desface cutia, puneti un pachet cu agent anti-umiditate in cutia originala a invertorului).
- > Depozitati invertorul la temperaturi intre -25 grade Celsius si +60 grade Celsius cu umiditatea relativa de la 0-100%, fara condens.
- > Invertorul trebuie depozitat in spatii curate si uscate pentru a fi protejat de praf si vapori de apa.
- > Invertoarele de 3kW cu o singura intrare MPPT pot fi stivuite cate 8, invertoarele de 5kW/6kW cu doua intrari MPPT pot fi stivuite cate 6
- > Nu pozitionati invertorul in plan inclinat, pe o parte sau invers.
- > Inspectati periodic invertorul in timpul depozitarii. Inlocuiti imediat ambalajul daca se gasesc urme de rozatoare.
- > Asigurati-va ca invertorul este testat de personal autorizat inainte de instalare, dupa o perioada lunga de depozitare.

4 Instalarea

PERICOL

Nu instalati inverterul aproape de materiale inflamabile sau intr-o zona in care sunt depozitate materiale inflamabile sau explozive.

ATENTIONARE

Nu instalati inverterul intr-un loc usor accesibil personal-ului neautorizat care poate veni in contact cu oricare parte a carcasei sau radiator si pot suferi arsuri sau electrocutari.

4.1 Verificarea ambalajului

- La primirea inverterului, verificati ca ambalajul sa fie intact.
- Dupa inlaturarea ambalajului, verificati ca toate componentele sa fie intacte si complete, in concordanta cu lista din comanda.
- Examinati inverterul sa nu aiba facute reparatii ale crapaturilor si zgarieturilor.

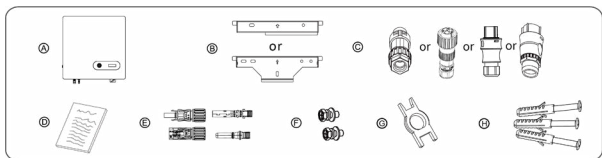

Notatie	Livrabil
A	Inverterul
B	Panoul din spate
C	Conector de iesire AC
D	Lista componentelor
E	Grup de conectori terminal DC
F	Suruburi
G	Unealta pentru indepartarea conectorului DC
H	Suruburi de rezerva (pentru atasarea suportului si a panoului din spate)

Figurile 4.1 Continutul ambalajului

NOTIFICARE!

Daca se identifica orice defect va rugam sa contactati unitatea de unde ati achizitionat echipamentul.

NOTIFICARE!

Panouri fotovoltaice pentru invertoare non-isolated. Acest tip de inverter este insotit de instructiuni de instalare ce specifica ca si cerinte panouri fotovoltaice care sunt certificate IEC 61730, Clasa A. Daca tensiunea maxima de retea e mai mare decat tensiunea maxima a matricii de panouri PV, atunci se impun panouri PV care au rating-ul tensiunii maxime in functie de tensiunea de retea

4.2 Manipularea invertorului

Dupa ce ati verificat ambalajul exterior, mutati invertorul in zona in care se doreste instalarea, in pozitie orizontala (cu fata in sus). Manipulati invertorul cu ajutorul celor 2 manere de pe lateralul carcasei.



Figura 4.2 Manipularea invertorului



ATENTIONARE



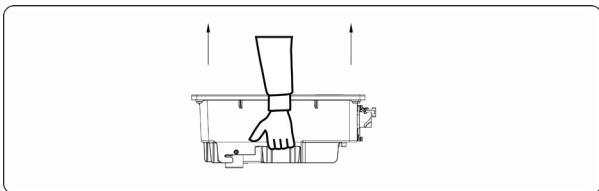

- >Nu asezati invertorul pe terminalele de conectare deoarece porturile de pe partea inferioara nu suporta greutatea acestuia.
- >Cand asezati invertorul in pozitie orizontala, cu fata in sus, asezati-l pe o bucata de polistiren expandat sau carton pentru a-i proteja carcasa.

4.3 Identificarea tipului de inverter

4.3.1 Cod de identificare

Dupa mutarea invertorului din cutie, identificati tipul de inverter dupa numarul de pe eticheta laterala. Acea eticheta trebuie sa contina informatii importante despre produs: model, specificatii tehnice, simbolurile de conformitate.

4.3.2 Simboluri de conformitate

Simbol	Descriere
	Pericol de electrocutare! Exista tensiune reziduala in invertor. Are nevoie de 5 minute pentru descarcarea completa.
	Invertorul nu trebuie atins in functionare. Carcasa si radiatorul sunt extrem de fierbinti.
	Pericol de electrocutare! Pericol de descarcare electrica! Acces strict pentru personal autorizat!
	Cand durata de viata a invertorului a expirat, respecta reglementarile locale in vigoare pentru reziduurile de acest tip. Nu aruncati invertorul impreuna cu reziduurile menajere.
	Acest invertor este in conformitate cu reglementarile TUV.

4.4 Criterii de instalare

Aplicabile pentru montarea pe perete, așa cum este descris în detaliu mai jos.

4.4.1 Stabilirea pozitiei de instalare

Criterii de baza

- Invertorul are protectie IP65 si poate fi instalat in interior sau exterior.
- Metoda de instalare si pozitia este determinata in functie de greutatea si dimensiunile invertorului.
- Nu instalati invertorul intr-un loc usor accesibil de personal neautorizat care poate veni in contact cu oricare parte a carcasei sau radiator si pot suferi arsuri sau electrocutari.
- Nu instalati invertorul in zone cu risc de incendiu sau materiale inflamabile.

Criteria pentru mediu de instalare

- a. Temperatura ambientală trebuie menținută sub 50 grade Celsius pentru o funcționare corectă și o durată de viață mai mare.
- b. Invertorul trebuie instalat într-un spațiu foarte bine ventilat pentru a asigura disiparea eficientă a căldurii.
- c. Invertorul nu trebuie expus direct la razele soarelui, ploaie, ninsoare pentru a-i extinde perioada de viață. Este recomandat să fie instalat în interior. Dacă nu este posibilă instalarea în interior este recomandată achiziționarea unei copertine sau acoperis, cum sugerează schița de mai jos.



Figura 4.3 Mediul de instalare cu copertina

Criteria pentru peretele de instalare

- a. Adăpostul unde se va efectua instalarea invertorului trebuie să fie rezistent la foc. Nu instalați invertorul aproape de materiale inflamabile.
- b. Peretele pe care se va efectua instalarea trebuie să susțină greutatea invertorului.
- c. Nu instalați invertorul pe pereți falși, plăci de gips-carton sau pereți slab izolați fonic pentru a evita zgomotele puternice produse în timpul funcționării.

Criteria pentru adăpost

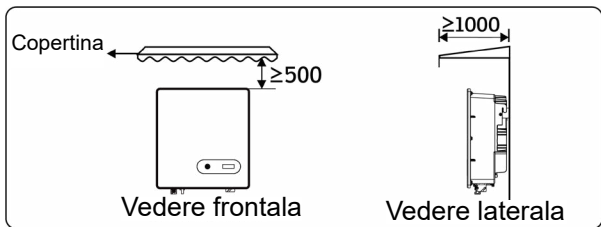
- a. Este recomandată instalarea la nivelul ochilor pentru a facilita operarea și mentenanța.
- b. Asigurați un spațiu suficient pentru a disipa căldura emisă și pentru a se asigura o instalare corectă, cum se arată în figura următoare.



Figura 4.4 Cerințe privind spațiul de instalare(mm)

c. La instalarea invertoarelor multiple, instalați-le pe aceeași linie, dacă există suficient spațiu la dispoziție ca în **Figura 4.5**). În caz contrar, instalați-le sub forma unui triunghi echilateral ca în **Figura 4.6**) sau unul sub celălalt cum arată **Figura 4.7**).



Figura 4.5 Instalare pe aceeași linie (mm)

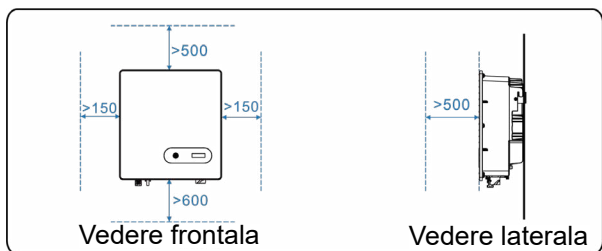

Figura 4.6 Instalare în modul triunghiular(mm)

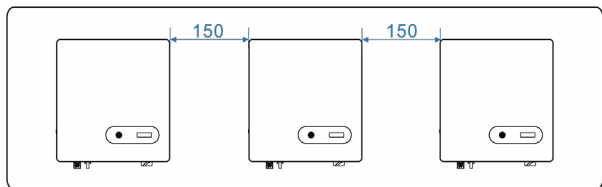

Figura 4.7 Instalare în modul stivuit(mm)

NOTIFICARE!

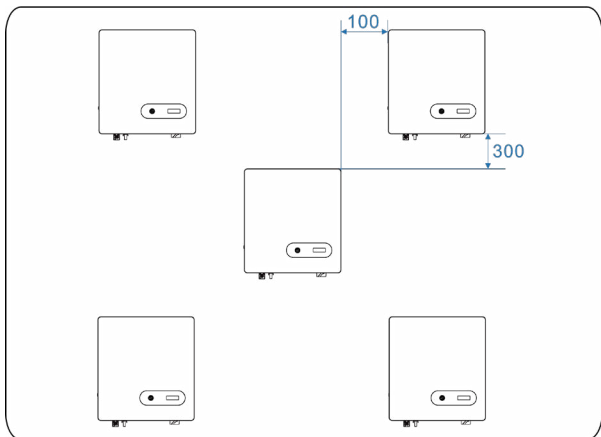
Cu cât e mai mare temperatura ambientală a mediului de instalare cu atât trebuie păstrată o distanță mai mare între invertoare.

4.4.2 Criterii pentru pozitia de instalare

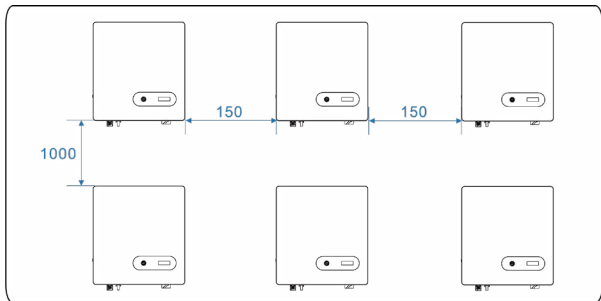
Instalarea invertorului se face in pozitie verticala la un unghi de inclinare maxim de 15 grade pentru o disipare a caldurii eficienta. Exemple de instalare corecta si gresita in schitele din **Figurile 4.8&4.9** de mai jos.



Figura 4.8 Instalare corecta



Figura 4.9 Instalare gresita

NOTIFICARE!

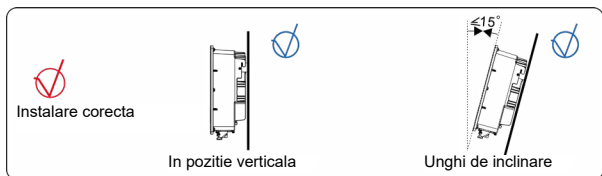
Instalarea invertorului in pozitie gresita va duce la defectarea sa.

4.5 Instalarea panoului din spate

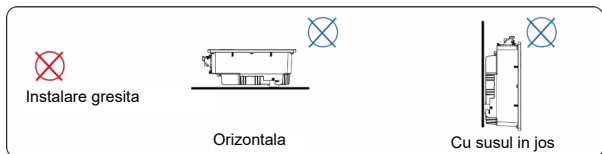
Inainte de instalarea efectiva a invertorului se va instala panoul / suportul din spate.

Pasul 1 Scoateti panoul din spate din ambalaj.

Pasul 2 Masurati unde se vor executa orificiile de fixare utilizand acest panou, cum e prezentat in schita de mai jos. (Figura 4.10)

NOTIFICARE!

Recomandarea de montare a panoului din spate pentru versiunea de 5K/6K este cu orificiile 1, 4 sau 2, 3.

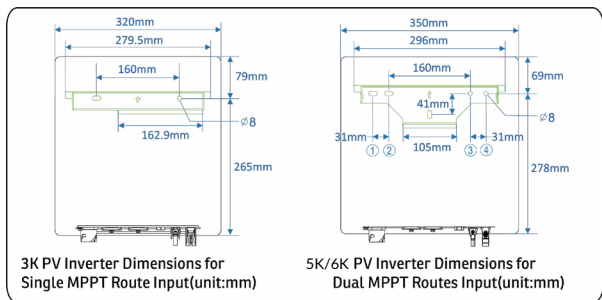

Figure 4.10 Determinarea pozitilor pentru orificii (mm)

Pasul 3. Pozitionati orificiile corect cu ajutorul unui indicator de nivel si marcati-le utilizand un marker ca in figura de mai jos. (figura 4.11).



Figura 4.11 Marcarea pozitiei orificiilor utilizand un marker

Pasul 4 Gauriti in locul marcat cu ajutorul unui ciocan rotopercurtor si instalati diblurile ca in **Figura4.12**.

⚠ PERICOL

Inainte de a gauri peretele asigurati-va ca nu atingeti cabluri electrice sau tevi de apa.

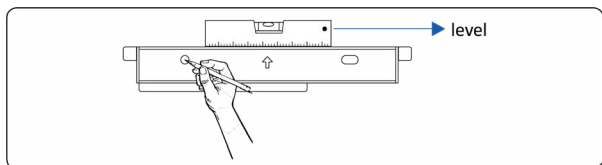
a. Gauriti in pozitiile marcate anterior la o adancime de 60mm utilizand un ciocan rotator cu varful de dimensiunea $\Phi 10\text{mm}$.

b. Strangeti partial un surub pe diblu si introduceti-l utilizand un ciocan de cauciuc.



Figura 4.12 Perforarea găurilor și instalarea diblurilor(mm)

Step 5 Aliniați panoul din spate cu gaurile facute, introduceți și strângeți suruburile cu o cheie dinamometrică (forța de strângere 2-2.5 Nm) cum e prezentat în figura de mai jos.

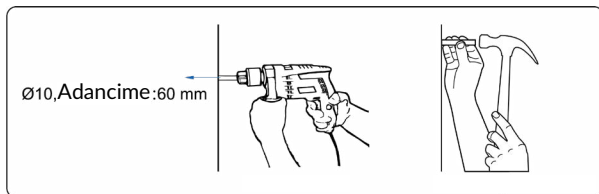

Figura 4.13 Instalarea panoului

4.6 Instalarea invertorului propriu-zis

Urmati pasii de mai jos:

Pasul 1 Folosind manerele de pe lateralele invertorului ridicati-l si aliniati-l cu panoul din spate deja montat.

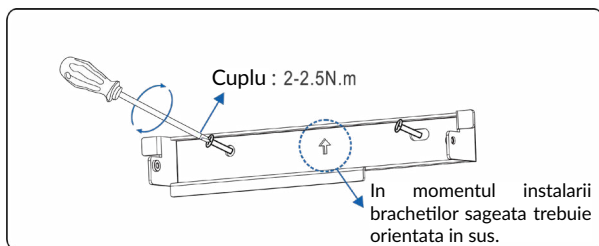
Step 2 Monteaza invertorul pe acest panou aliniind orificiile de fixare ca in **Figura 4.14**.

Step 3 Strangeti suruburile hexagonale in ambele parti ale invertorului cu o forta de 1.2Nm si respectiv 3Nm. Specificatiile suruburilor pentru 3K si 5K/6K sunt M4 si respectiv M6, cum e prezentat in figura de mai jos.



Figura 4.14 Fixarea invertorului

! PERICOL

Înainte de a face orice conexiune electrică, asigurați-vă că ambele comutatoare pentru curentul alternativ AC, respectiv curentul direct DC sunt oprite. În caz contrar, riscați fatalitatea din cauza tensiunilor mari prezente pe cablurile AC și DC.

5.1 Conectarea cablului de protecție împământare (PGND)**5.1.1 Pregătire**

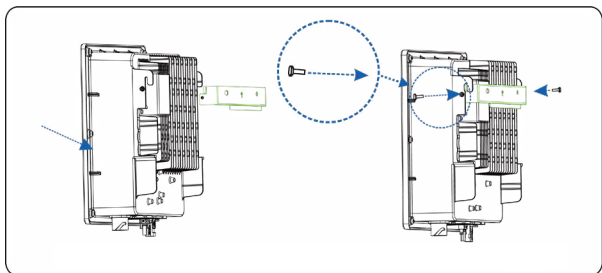
Pregătiți cablul de împământare și terminalele OT.

- a. Cablul de împământare: cabluri exterioare cu miez de cupru cu o secțiune transversală de 4 mm sau mai mare.
- b. Terminal OT: OT6-4.

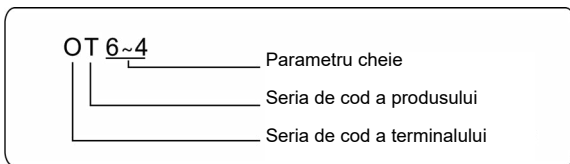
**BINE DE STIUT!**

O împământare corectă a invertorului ajută la diminuarea efectelor caderilor de tensiune și la îmbunătățirea rezistenței împotriva interferențelor electromagnetice (EMI). Conectați cablul de împământare înainte de a conecta cablurile de curent alternativ, continuu și a celor de comunicație.

BINE DE STIUT!

Este recomandat ca împământarea să se execute în proximitate. Pentru un sistem format din invertoare multiple în paralel este necesară ca împământarea lor să fie asigurată de puncte echipotentiale.

5.1.2 Procedura de cablare

Pasul 1 Indepartati stratul izolator de pe capatul cablului de impamantare utilizand un cleste de dezimbrare, pe o portiune putin mai lunga cu 2-3 mm decat clama terminalului OT, cum este prezentat in schema de mai jos.



Figura 5.1 dezizolare(mm)

Pasul 2 Introduceti firele expuse ale cablului in clama terminalului OT si strangeti-le utilizand clesti hidraulici, cum este prezentat in schema de mai jos.

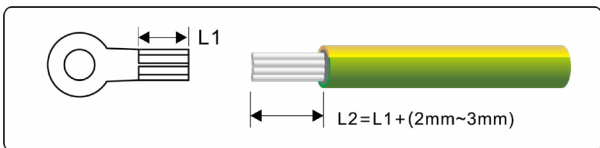

Figura 5.2 Prinderea in clama a cablului (mm)

Pasul 3 . Indepartati suruburile de la punctele de impamantare, cum este prezentat in schema de mai jos.

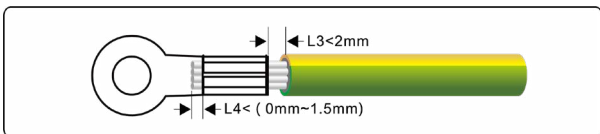

Figura 5.3 Indepartarea suruburilor de la punctele de impamantare

Pasul 4 Asigurați cablul PGND (după executarea pașilor 1&2) utilizând un surub de împământare și strângeți-l utilizând o cheie tubulară (forța 1.2 Nm) cum este prezentat în schema de mai jos.

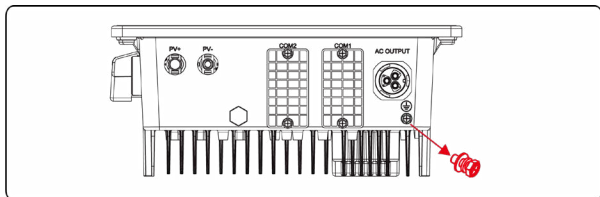

Figura 5.4 Asigurați cablul PGND

5.2 Conectarea cablului de ieșire curent alternativ (AC)

5.2.1 Pregătiți cablul și terminalele AC.

a. Cablul pentru curent alternativ AC: cablul cu miez de cupru pentru exterior.

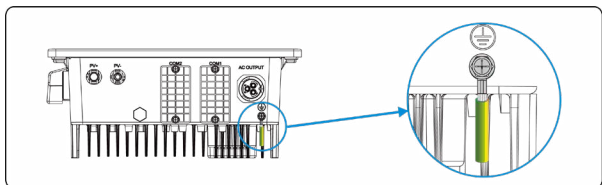
Tabelul de mai jos descrie specificațiile exacte.

Model inverter	Tip cablu	Suprafața secțiunii (mm ²)		Diametrul exterior al cablului (mm)	
		Interval	Valoare recomandată	Interval	Valoare recomandată
3K	exterior	4~6	4	10~14	14
5K/6K	exterior		6		

Tabelul 5.1 Specificațiile cablului AC

b. Specificațiile recomandate pentru siguranța sunt prezentate în tabelul de mai jos.

Model inverter	Valoare recomandată
3K	25A
5K	32A
6K	40A

Tabelul 5.2 Specificația siguranței automate



AVERTISMENT





O siguranță suplimentară trebuie instalată pe ieșirea AC a invertorului pentru a se asigura o deconectare sigură de la rețeaua de electricitate.



AVERTISMENT

Nu conectați niciun dispozitiv între terminalele de ieșire AC ale invertorului și siguranță. Toate conexiunile se vor face după acest punct de siguranță.

5.2.2 Procedura de conectare a cablurilor AC

 REFERINȚĂ	Exista 4 tipuri de terminale AC care se pot utiliza. Consultati livrabilele.		
 Cel mai utilizat	 optional	 optional	 optional

Pasul 1 Este recomandată utilizarea cablurilor din cupru cu nuclee multiple pentru exterior.

Îndepărtați o cantitate suficientă din izolația cablului de ieșire AC utilizând un clește de dezizolare.

Pasul 2 Treceti cablul AC prin piulita de cauciuc, sigiliu și așa mai departe. Va rugăm să consultați **figura 2**.

Pasul 3 Strângeți cele 3 suruburi și asigurați-vă că capetele acestora nu depășesc suprafața alocată, apoi atașați conectorul AC cum arată **figura 3**.

Pasul 4 Introduceți conectorul AC în invertor.

REFERINȚĂ!

Exista 4 tipuri de terminale AC care se pot utiliza. Consultati livrabilele. **Tip A** este cel mai întâlnit. În cazul în care utilizați orice tip de șurub A, B, C sau D strângeți capșonul rezistent la apă pentru a evita slăbirea lui. Luați ca exemplu șurubul tip A folosit în demonstrația vizuală de mai jos.

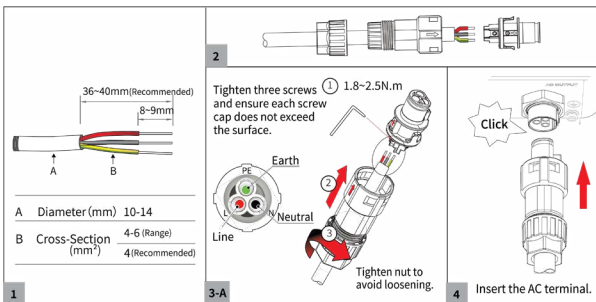

Procesul de cablare cu **tipurile B, C si D** sunt prezentate mai jos.
Indiferent de tipul folosit strangeti capisonul rezistent la apa pentru a evita slabirea lui.

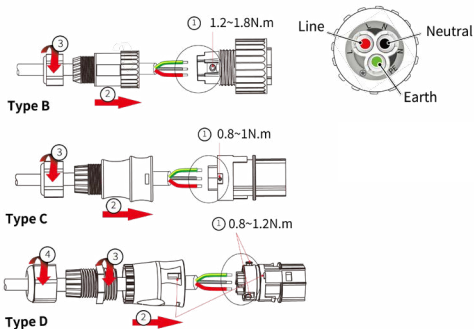

3-B/C/D

NOTE!

Faza (line), neutrul (neutral) si impamantarea (ground) corespund cu notatia L, N si G, atat ale terminalului cat si ale conectorului AC. Daca sunt legate gresit inverterul nu va functiona.

Pasul 5 După conectarea terminalului AC, instalați mansonul de protecție (optional) cum e prezentat mai jos.

La utilizarea **tipului B**, mansonul de protecție este opțional.

Pasul 5 este necesar doar atunci când **Tipul B** vine cu manson de protecție.

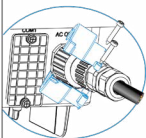

După ce terminalul de **tip B** este conectat, asigurați mansonul de protecție cu suruburi pentru a preveni slăbirea conexiunilor.

5

5.3 Conectarea sîrurilor de panouri fotovoltaice

PERICOL

În conectarea panourilor fotovoltaice este nevoie să se respecte următoarele precauții pentru a se evita șocul electric.

Panourile fotovoltaice generează electricitate când sunt expuse la razele solare astfel ca se poate genera un șoc electric. La instalarea lor, recomandăm acoperirea lor cu un material opac.

Înainte de a conecta cablurile DC de intrare, asigurați-vă că tensiunea în zona DC este în limitele de siguranță și comutatorul DC al invertorului este oprit. În caz contrar, tensiunea înaltă va genera un șoc electric.

Atunci când invertorul este legat la rețeaua electrică, nu este permisă intervenția sau mentenanța la cablurile de intrare DC, cum ar fi deconectarea unui șir de panouri. Abia după ce invertorul este complet oprit se poate realiza intervenția.

AVERTISMENT

În împământarea sirurilor de panouri fotovoltaice este necesară respectarea următoarelor precauții pentru a se evita izbucnirea unui incendiu.

Panourile conectate în serie trebuie să fie cu specificații identice.

Tensiunea maximă în gol a fiecărui sir de PV trebuie să fie mai mică sau egală cu tensiunea admisibilă.

Curentul maxim de scurtcircuit al fiecărui sir de PV trebuie să fie mai mic sau egal cu curentul admisibil.

Terminalele pozitiv și negativ ale panourilor trebuie să fie conectate la terminalele pozitiv și negativ ale invertorului.

În timpul instalării sirurilor PV și a invertorului, terminalele + și – ale panourilor nu trebuie puse în scurtcircuit.

5.3.1 Pregătirea

Modul de conectare al panourilor la terminalele PV:

Model Invertor	Numarul traseelor de intrare
3K	Conectat la 1 ruta MPPT
5K/6K	Conectat la 2 rute MPPT

Cablul de intrare DC al panourilor și conectorii sunt pregătiți. Tabelul de mai jos prezintă specificațiile recomandate pentru cablul de cupru pentru exterior.

Model Invertor	Tip cablu	Suprafața secțiunii (mm ²)		Diametrul exterior cablu (mm)
		Interval recomandat		Interval
3K	Cablul comun în standardul industriei (model PV1-F)	4~6	4	5~8
5K/6K				

Tabelul 5.3 Specificații recomandate pentru cablul de intrare DC

Conectorii sirurilor de PV: Sunt folositi conectori de intrare de curent continuu, dupa cum se vede in **Figura 5.8** si **Figura 5.9**.



Figura 5.8 Ilustratie Conector pozitiv



Figura 5.9 Ilustratie Conector negativ

BINE DE STIUT!

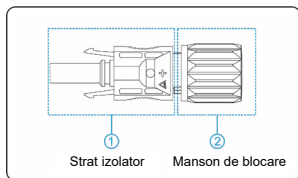
Conectorii metalici pozitivi si negativi sunt livrati impreuna cu conectorii de plastic aferenti in momentul expedierii. Dupa desfacerea ambalajului, va rugam sa tineti conectorii separat pentru a evita orice confuzie.

Procedura de conectare a panourilor fotovoltaice

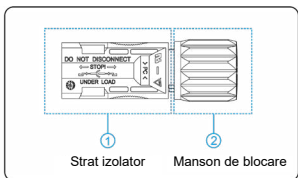
Pasul 1 Indepartati suficient izolatia cablurilor electrice pozitiv si negativ utilizand un cleste de dezimbrare, cum este prezentat in figura urmatoare.



Figura 5.10 Indepartarea izolatiei cablului DC (mm)

Pasul 2 Inserati partea dezizolata a cablurilor electrice pozitiv si negativ in partea de metal a terminalelor corespondente si fixati-le impreuna folosind un instrument de sertizat.

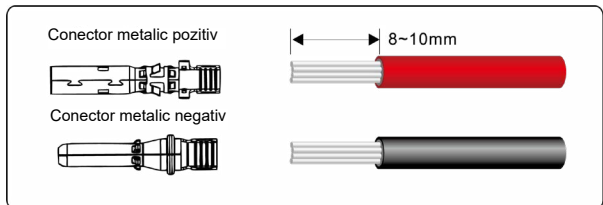

Figura 5.11 Sertizarea unui conector metalic

Pasul 3 Inserati cablurile sertizate in conectorii corespondenti negativ si pozitiv pana auziti un clic, cum prezinta figura de mai jos.

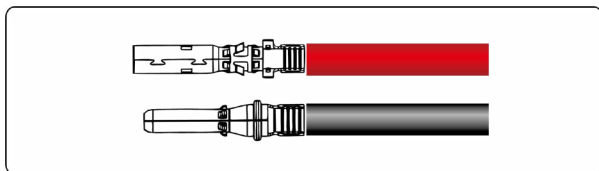
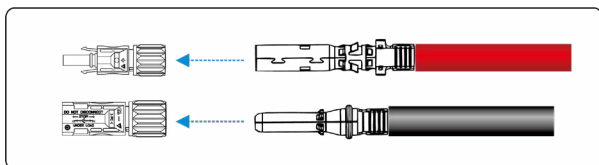

Figure 5.12 Atasarea la conectori

Pasul 4 Strangeti piulitele de blocare la conectorii pozitiv si negativ utilizand o cheie de indepartare, cum prezinta figura de mai jos.



Figura 5.13 Blocarea conectorilor

Pasul 5 Masurati tensiunea pe fiecare sir al rutelor utilizand un multimetru. Asigurati-va ca polaritatile cablurilor de intrare DC sunt corecte, cum este prezentat in figura de mai jos.

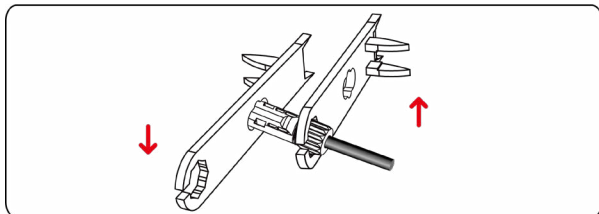

Figura 5.14 Masurarea tensiunii pe fiecare canal al sirului

Pasul 6 Insetati conectorii pozitiv si negativ in terminalele corespunzatoare ale invertorului pana auziti un clic, cum se prezinta mai jos.

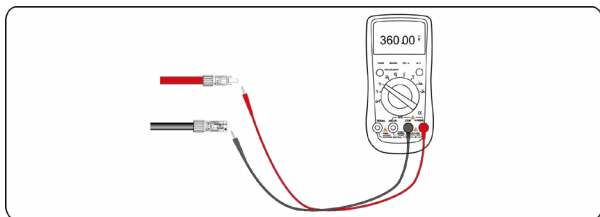

Figura 5.15 Conectarea la invertor

Pasul 7 Dupa conectarea sirurilor de panouri fotovoltaice, asigurati-va ca toti conectorii sunt blocati in pozitie, miscand putin de ei.

5.4 Conectarea cablurilor de comunicatie

5.4.1 Modalitati de comunicatie

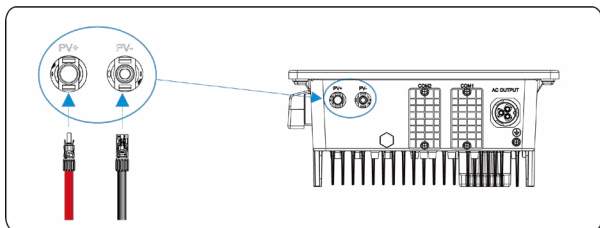
Asigurarea comunicatiei dintre invertor si alte device-uri se poate realiza prin urmatoarele modalitati: Bluetooth, WI-FI, GPRS, RS485

Modul Bluetooth

Pentru a folosi aceasta modalitate porniti functia Bluetooth pe telefon, setati parametrii de functionare si monitorizati invertorul prin aplicatia mobila.

Pentru detalii va rugam sa consultati manualul de utilizare al aplicatiei.

Modul WI-FI & GPRS & RS485

Pentru a folosi oricare modalitate de comunicare va rugam sa consultati tabelul de mai jos pentru detalii si setari.

Modul	Descriere functionalitate
WIFI	Acest mod se implementeaza prin Cloud si modul wireless al invertorului pentru a monitoriza statusul. Pentru mai multe detalii va rugam sa consultati manualul de utilizare al aplicatiei WI-FI.
GPRS	Acest mod se implementeaza prin Cloud si modul wireless al invertorului pentru a monitoriza statusul. Pentru mai multe detalii va rugam sa consultati manualul de utilizare al aplicatiei GPRS.
RS485	Interfata RS485 monitorizeaza statusul invertorului si il incarca intr-un server Cloud. Pentru mai multe detalii va rugam sa consultati manualul de utilizare al interfetei RS485.
NOTA	Aceste module de comunicare se pot achizitiona de la compania producatoare a invertorului. viteza de transmitere date suportata de RS485: 9600BPS

Tabelul 5.4 Descrierea modulelor de comunicatie

5.5 Limitator de putere senzor

5.5.1 Diagrama inverterului + CT



Figura 5.16 Diagrama inverterului + CT



Figura 5.17 Setari prin intermediul aplicatiei

- Funcția limitatorului de putere setat pe "CT sensor".
- Stabilită poziția unde este instalat CT-ul, pe rețea sau pe sarcină.
- Setată puterea maximă ce se dorește a fi injectată în rețea, dacă este cazul.
- Setată raportul curenților CT-ului.

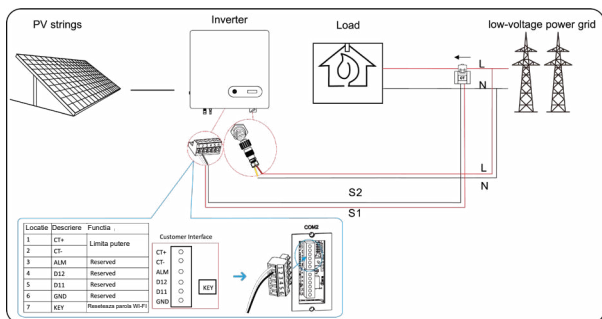
5.5.2 Diagrama invertorului + power meter

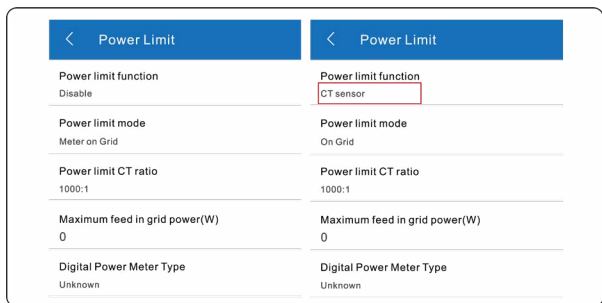
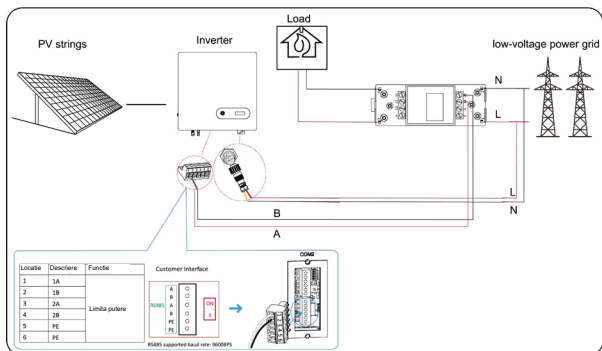

Figure 5.18 Diagrama invertorului + Power meter

Power Limit	Power Limit
Power limit function Disable	Power limit function Digital Power Meter
Power limit mode Meter on Grid	Power limit mode On Grid
Power limit CT ratio 1000:1	Power limit CT ratio 1000:1
Maximum feed in grid power(W) 0	Maximum feed in grid power(W) 0
Digital Power Meter Type Unknown	Digital Power Meter Type DDSU666

Figura 5.19 Setari prin intermediul aplicatiei

- Setati Functia de limitare pe digital Power meter.
- Setati tipul de digital Power meter.
- Stabiliti pozitia unde este instalat Meter-ul, pe retea sau pe sarcina.
- Setati puterea maxima ce se doreste a fi injectata in retea, daca este necesar.
- Ajustati valorile campului "Power limit CT ration" doar in cazul folosirii unui CT.

In momentul activarii functiei de limitare a puterii injectate in retea modulul RS485 va comunica cu meterul digital utilizand protocolul Modbus-RTU 9600 BPS, 8 data bit, 1 stop bit, no parity data format) prin adresa de comunicare 1. Asigurati-va ca meter-ul este setat la Modbus-RTU, 9600, 8-N-1 cu adresa 1.

Pentru detalii va rugam consultati manualul de utilizare al Power meter-ului.

5.6 Verificari dupa instalare

Asigurati-va ca instalarea inverterului s-a facut dupa indicatiile din tabelul de mai jos.

1. Niciun obiect strain nu se afla la interiorul inverterului.
2. Toate suruburile, in special cele folosite la legaturi electrice, sunt bine stranse si fixate in locasurile corespunzatoare.
3. Inverterul este instalat corect si in siguranta.
4. Cablurile de impamantare, DC, AC si cele de comunicatie sunt corect legate si in siguranta.
5. Asigurati-va ca nu exista circuite deschise sau scurtcircuit la nici unul din terminalele AC si DC folosind un multimetru.
6. Sectoarele care trebuie izolate de apa cum sunt terminalele AC si portul RS485 cu dopuri hidroizolante.
7. Acoperitoarele terminalor AC sunt bine stranse.
8. Terminalele inactive sunt izolate / sigilate.
9. Toate simbolurile de siguranta de pe inverter sunt intacte si complete

Tabelul 5.5 Verificari dupa instalare

6 Operarea sistemului

6.1 Pornirea invertorului

Step 1: Porniti comutatorul de siguranta al AC.

Step 2: Daca invertorul are intrerupator de pornire, actionati-l.

Step 3: Observati statusul LED al invertorului conform cu **tabelul 7.1**

BINE DE STIUT!

In momentul in care luminile LED indica ca invertorul functioneaza on-grid inseamna ca functioneaza in parametrii corecti. Pentru orice alta intrebare despre functionarea invertorului va rugam sa cereti suportul producatorului.

6.2 Oprirea invertorului

Step 1: Operati o comanda de oprire din aplicatia mobila.

Step 2: Inchideti comutatorul de siguranta al AC.

Step 3: Daca invertorul are un comutator de oprire, actionati-l.



AVERTISMENT

Chiar si dupa oprirea invertorului electricitatea si caldura reziduala ramasa poate cauza electrocutari sau arsuri grave. Mentenanta invertorului trebuie sa se efectueze la 10 minute dupa oprirea completa a invertorului.

7 Interfata utilizatorului

Interfata de comunicare a invertorului cu utilizatorul este prin lumini LED sau la unele modele, ecran LCD.

Luminile LED-urilor pot fi de 3 culori: albastru, verde si rosu.

Pentru mai multe detalii consultati **tabelul 7.1**

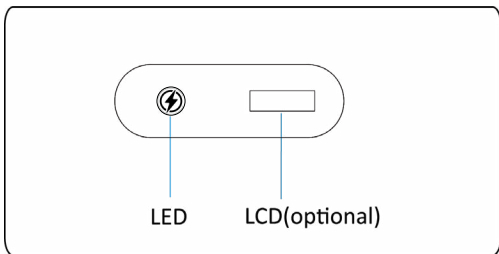

BINE DE STIUT!

Setarile si informatiile se pot vizualiza in aplicatia mobila. Pentru detalii, consultati manualul de utilizare al aplicatiei. Manualul aplicatiei este la dispozitie pe site-ul www.nJoy.global

7.1 Definierea informatiilor starilor HMI

Indicator LED	Descriere	Stare
Albastru	Repaus / stand-by	Clipeste incet
	Functionare normala	Aprins
Verde	Functionare limitata	Aprins
Rosu	Vezi mai jos	
Avertisment	Ecran LCD	Stare
Supratensiune in grid	A0 Grid OV	LED rosu clipeste incet
Tensiune prea scazuta in grid	A1 Grid UV	LED rosu clipeste incet
Fara curent de la grid	A2 Grid Loss	LED rosu clipeste incet
Frecventa peste limita in grid	A3 Grid OF	LED rosu clipeste incet
Frecventa sub limita in grid	A4 Grid UF	LED rosu clipeste incet
Supratensiune in panourile fotovoltaice	B0 PV OV	LED rosu clipeste rapid
Eroare rezistenta de izolatie	B1 Imp abn	LED rosu clipeste rapid
Eroare curent scurgere	B2 Lkge abn	LED rosu clipeste rapid
Eroare sistem de control al puterii	C0 Powerfail	LED rosu aprins
Eroare arc electric	C1 Arc fault	LED rosu aprins
Eroare curent continuu de polarizare	C2 OP Dc OC	LED rosu aprins
Eroare releu inverter	C3 RLY abn	LED rosu aprins
Temperatura ridicata in inverter	C5 SYS OT	LED rosu aprins
Curent rezidual HCT anormal	C6 LkgCT abn	LED rosu aprins
Eroare sistem	C7 SYS err	LED rosu aprins

Eroare ventilator	C8 FAN lock	
Legatura CC subvoltata	C9 Bus UV	LED rosu aprins
Legatura CC supravoltata	CA Bus OV	LED rosu aprins
Eroare comunicare	CB COM err	LED rosu aprins
Versiune software incompatibila	CC FW Incomp	LED rosu aprins
Eroare EEPROM	CD EEP err	LED rosu aprins
Inconsistenta la esationare	CE Inconsis	LED rosu aprins
Circuit de amplificare anormal	CG Bst abn	LED rosu aprins
Comunicatii oprite	CN RMT OFF	

Tabelul 7.1 Definirea informatiilor starilor HMI

7.2 Ecran LCD - Rasfoirea automata si semnificatia simbolurilor afisate

Mod	Simbol afisat	Nota
Ecranul inverterului afiseaza urmatoarele secvente in modul Repaus / Stand-by	Astris 5K Ver 01.00.00	Nume produs Versiune
	Udc 360/360V Vac 220V	Tensiune PV Tensiune AC
	Today 80kWh Etot 8000kWh	Energie astazi Energie totala
	A0 Grid OV B1 Imp abn	Avertisment
Ecranul inverterului conectat la grid afiseaza informatia urmatoare:	Starting 60s	Timer

Ecranul invertorului conectat la grid afiseaza informatia urmatoare:	SE 5kTL Ver 01.00.00	Puterea de iesire Energia astazi
	Etot 8000kWh Htot 80000hr	Energie totala Total ore
	Vdc 350/350V Idc 8/8A	Tensiune panouri PV Sarcina PV
	Vac 220V Iac 28A	Tensiune AC Sarcina AC
	08:00 2018-08-08	Ora:minute An / luna/ ziua

Tablul 7.2 Ecran LCD - Rasfoirea automata si semnificatia simbolurilor afisate

8

Mentenanata



AVERTISMENT

Inainte de mentenanata sau punerea in functiune a intregului sistem, va rugam sa decuplati toate conexiunile la invertor si sa asteptati 10 minute dupa oprirea completa pentru a fi in siguranta.

8.1 Mentenanata periodica

Componenta de verificat	Continut de verificat	Actiune	Interval de mentenanata
Statusul iesirii invertorului	Consultati statisticile randamentului electric si monitorizati constant acest parametru	n/a	Saptamanal
Curatarea invertorului	Verificati periodic si asigurati-va ca radiatoarele sunt curate si nu sunt blocate de alte obiecte.	Curatati periodic radiatoarele	Anual

Starea de functionare a inverterului	Verificati ca inverterul sa nu fie avariata sau deformat. Verificati ce sunet emite inverterul in timpul functionarii. Verificati ca inverterul sa mentina o comunicatie buna.	Daca sunt observate defecte, inlocuiti partile care genereaza aceste defecte.	Lunar
Conexiunile electrice ale inverterului	Verificati si asigurati cablurile AC, DC si cele de comunicatie ca sunt bine prinse. Asigurati prinderea corecta a cablului PGND	Daca sunt observate defecte, inlocuiti cablul sau reconectati.	De 2 ori pe an

Tabelul 8.1 Mentenanta periodica

8.2 Depanare inverter

Atunci cand inverterul emite un avertisment se poate consulta tabelul de mai jos pentru cele mai comune semnale, explicatia si actiunile corespunzatoare.

Nume alarma	Cauza	Actiune recomandata
Supra tensiune in grid	Tensiunea in grid depaseste nivelul admis	<ol style="list-style-type: none"> 1. Daca alarma se declanseaza accidental atunci defectul in grid a fost temporar. Nu este necesara nicio actiune 2. Daca alarma se repeta contactati operatorul local al retelei electrice. Dupa obtinerea aprobarii autoritatilor, revizuiti parametrii care se refera la protectia electrica din aplicatia mobila 3. Daca alarma persista o perioada mai indelungata, verificati daca comutatorul AC sau terminalele sunt conectate sau daca este lipsa retea
Sub Tensiune in grid		
Peste frecventa		
Sub frecventa		

Supra tensiune la panourile PV	Tensiunea generata de panouri este mai mare decat permite invertorul	Verificati numarul de panouri si ajustati parametrii
Subtensiune la panourile PV	Tensiunea generata de panouri este sub limita de functionare in siguranta a invertorului	<ol style="list-style-type: none"> 1. Atunci intensitatea solara slabeste, tensiunea generata de panouri scade. Nu este necesara nicio actiune. 2. Daca fenomenul este intalnit atunci intensitatea solara este puternica, verificati panourile de scurtcircuit, circuit deschis etc
Rezistenta izolatie anormal	Un scurtcircuit s-a produs intre sirurile de panouri si impamantare. Panourile sunt instalat intr-un mediu umed sau cu umezeala prelungita	<ol style="list-style-type: none"> 1. Verificati rezistenta de izolatie fata de pamant a sirurilor de panouri. Daca exista un scurtcircuit, remediatii-l. 2. Daca rezistenta de izolatie e mai mica decat normal in conditii de umiditate, setati protectia la rezistenta de izolatie din aplicatie
Curent rezidual anormal	Rezistenta de izolatie fata de impamantare pe intrare e scazuta, lucru care produce curent rezidual	<ol style="list-style-type: none"> 1. Daca alarma porneste accidental, e posibil ca circuitul exterior sa aibe o scurgere accidentala. Invertorul va reveni la functionare normala imediat dupe ce se va remedia defectiunea. 2. Daca alarma porneste repetat sau dureaza mult timp, verificati rezistenta de izolatie fata de impamantare a sirurilor de panouri
Functionare atipica la panourile fotovoltaice	Sirul de panouri a fost obturat o perioada lunga de timp. Panourile imbatrinite sau deteriorate	<ol style="list-style-type: none"> 1. Verificati daca sirul de panouri este obturat. 2. Daca sirul de panouri este curat si neobturat verificati modulele PV sunt invecchite sau deteriorate .

Sirul de panouri conectat invers	Cablurile de la sirul de panouri a fost conectat invers ca polaritate	Verificati daca cablurile sirurilor de panouri sunt conectate corect. In caz contrar, corectati conectarea cablurilor conform cu manualul
BUS Subtensiune	Dezechilibru intern anormal in modulul de control al energiei. Se activeaza la schimbarea brusca a parametrilor de functionare a sirurilor de panouri sau a retelei	<ol style="list-style-type: none"> 1. Daca alarma se declanseaza ocazional, invertorul isi reia functionarea normala automat, dupa repararea defectului initial 2. Daca alarma se declanseaza in mod repetat, contactati unitatea de unde ati achizitionat echipamentul pentru suport tehnic
BUS Supratensiune		
Eroare Modul Invert		
Eroare BOOST		
Eroare EEPROM	Componenta EEPROM defecta	Inlocuiti placa de monitorizare
Nu se genereaza curent si alarma cu iluminare galbena este activa	Nu functioneaza comunicatia	Daca modemul sau alt dispozitiv de colectare date e folosit, resetati-l. Daca in continuare nu functioneaza, contactati furnizorul
Monitorizarea raporteaza tensiune 0 la iesire	Siguranta care protejeaza iesirea este arsa / sarita	Daca siguranta DC este afectata contactati suport tehnic. Daca nu e afectata, reporniti. Daca tot nu functioneaza, contactati suport tehnic.
Invertor deconectat de la retea	<ol style="list-style-type: none"> 1. Reteaua electrica are probleme 2. Siguranta DC arsa 	<ol style="list-style-type: none"> 1. Asteptati sa se remedieze problemele retelei electrice 2. Reporniti intrerupatorul sigurantei DC si daca se defecteaza des, contactati suportul tehnic.

Detectie arc electric	Descarcari electrice	<p>a. Verificati conexiunile echipamentului, inclusiv integritatea firelor, fixarea clemelor si papucilor</p> <p>b. Dupa eliminarea defectiunilor, opriti alimentarea cu curent (continuu si alternativ) si reporniti inverterul sau apasati AFD Reset in aplicatie pentru a elimina alarma</p>
-----------------------	----------------------	---

Table 8.2 Depanare inverter

BINE DE STIUT!

Daca alarmele nu se pot stinge in urma actiunilor recomandate, contactati suportul tehnic.

8.3 Deinstalarea inverterului

Pentru a indeparta inverterul va rugam sa urmati urmatoarea proedura:

Pasul 1: Deconectati toate cablurile atasate la inverter, inclusiv cele de comunicatie, intrare DC, lesire AC si cablul PGND.

NOTA!

La deconectarea conectorului intrarii DC, inserati cheia de departare la conectorul baioneta, apasati cheia in jos si scoateti cu grija conectorul.

Pasul 2: Scoateti inverterul de pe panoul de instalare.

Pasul 3: Indepartati panoul de pe perete.



AVERTISMENT

Inainte de a scoate conectorul DC de intrare, verificati cu grija si asigurati-va ca intrerupatorul DC este oprit pentru a evita vatamari corporale si defecte ale inverterului.

În momentul în care perioada de viață a invertorului a expirat, **NU ARUNCATI** invertorul împreună cu gunoiul menajer, ci respectați procedurile locale de colectare a deșeurilor de acest tip.



Dezafectarea echipamentelor electrice și electronice vechi

(Se aplică pentru țările membre ale Uniunii Europene și pentru alte țări europene cu sisteme de colectare separată)

Acest simbol aplicat pe produs sau pe ambalajul acestuia indică faptul că acest produs nu trebuie tratat ca pe un deșeu menajer.

El trebuie predat punctelor de reciclare a echipamentelor electrice și electronice.

Asigurându-vă că acest produs este dezafectat în mod corect, veți ajuta la prevenirea posibilelor consecințe negative asupra mediului și a sănătății umane, care ar fi putut surveni dacă produsul ar fi fost dezafectat în mod necorespunzător.

Reciclarea materialelor vă ajută la conservarea resurselor naturale.



Memo

A series of horizontal dotted lines spanning the width of the page, providing a template for writing a memo.



Memo

A series of horizontal dotted lines for writing, filling the main body of the page.

