

AKRIBOS VC-1020 Sensor Unit

Installation Manual

System : VC-1020 Sensor Unit
Issued : May 12th 2015 [First Edition]
Issued by : Giken Trastem Co., Ltd.
Distribution to: Sensor Installer, Installation Engineer

Version: IM-VC1020-1505-1-EN

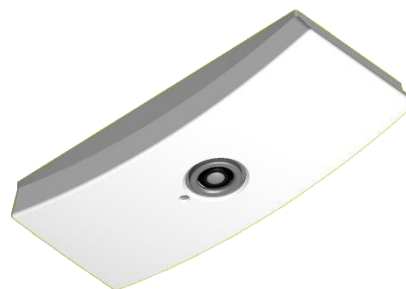

Contents

1. INTRODUCTION.....	1
2. SYSTEM DIAGRAM / INSTALLATION WORK DETAILS	1
3. SENSOR UNIT INSTALLATION AND WIRING	2
4. SENSOR INSTALLATION LOCATION EXAMPLE.....	4
5. SENSOR DESCRIPTION.....	6
6. SENSOR UNIT INSTALLATION	7
7. WEB SETTINGS	11
8. CONNECT TO NETWORK.....	11
9. SENSOR UNIT SPECIFICATIONS	12

SAFETY INDICATIONS

This section provides notes to use the product safely. Please read this section carefully to ensure proper and safe use of the product.



Warning

- ⊘ • Do not operate this product in such a way that a malfunction or failure could directly affect human life.
- ⓘ • If there is any abnormality such as smoke or an unusual smell from the product, stop using it immediately.
- ⊘ • Do not drop or hit the product. If the product has been damaged, stop using it immediately.
- ⊘ • Do not disassemble, modify, or repair the product. Doing so may cause fires and malfunctions.
- ⓘ • This product is class A information technology equipment. Using the product in a household environment can cause electronic jamming. In such a case, the user should take appropriate measures.
- ⓘ • Use the product with the cover firmly attached to prevent falling.



Caution

- ⊘ • This product is intended for indoor use only. Do not install it outdoors.
- ⊘ • This product cannot be used in general households.
- ⊘ • Do not install the product in the following places: (1) Places subject to direct sunlight, (2) Places near fire or hot and humid places, (3) Places where condensation can occur, (4) Places to which vibrations are transmitted directly, and (5) Places affected by rain or water.
- ⊘ • The inside of the product can reach a high temperature during operation.
- ⊘ • Do not pour or apply chemicals such as thinner, benzene, air freshener, or insecticide on the product.

FCC Part 15 Subpart B Class A

This device complies with part 15 of the FCC Rules.

Operation is subject to the following two conditions:

- (1) This device may not cause harmful interference.
- (2) This device must accept any interference received, including interference that may cause undesired operation.

This equipment has been tested and found to comply with the limits for a Class A digital device, pursuant to part 15 of the FCC Rules. These limits are designed to provide reasonable protection against harmful interference when the equipment is operated in a commercial environment. This equipment generates, uses, and can radiate radio frequency energy and, if not installed and used in accordance with the instruction manual, may cause harmful interference to radio communications. Operation of this equipment in a residential area is likely to cause harmful interference in which case the user will be required to correct the interference at his own expense.



The CE marking indicates compliance to 2004/108/EC EMC Directive with Standards EN55022 Class A ; EN55024

Giken Trastem assumes no responsibility if the installation and wiring connection which are stated in the instruction manual provided together with this product is not carried out, or if the AC adapter that is provided together with this product is not used, or when product without CE marking is connected to this device.

Conditions of use:

This product is not intended for use in any safety-critical or personal safety application. GIKEN TRASTEM assumes no liability for any accident resulting in personal injury, death, or property damage if this product has been used in the above conditions.

1. AKRIBOS VC-1020 INTRODUCTION

SENSOR UNIT

The sensor detects and tracks the number of people accurately using Image Recognition technology. The sensor is installed on the ceiling of entrances and passageways of retail, public facilities etc. to capture movements of people from above.

IN and OUT traffic data is recorded to the sensor continuously every minute and the collected data is sent to the designated server via LAN.

Traffic data can be compiled and used as marketing information.

The sensor can cover movements of the people in a wide area and recognizes and tracks the movements of people accurately therefore can omit people hovering near the counting area to provide an accurate traffic count.

This manual AKRIBOS (VC-1020 Sensor Unit) Installation Manual (Overseas)” explains the required steps to install the system.

This manual is intended for the system installer.

Please follow the steps indicated in this manual when installing the sensor unit.

2. AKRIBOS VC-1020 SYSTEM DIAGRAM / INSTALLATION WORK DETAILS

The system diagram below illustrates a general system installation of a mid-scale facility.

Details of SENSOR UNIT ->PoE HUB ->Management PC connection example. (refer to Fig. 1)

The cable length from the Sensor Unit to PoE HUB is max. **100m (109.3yds)**.

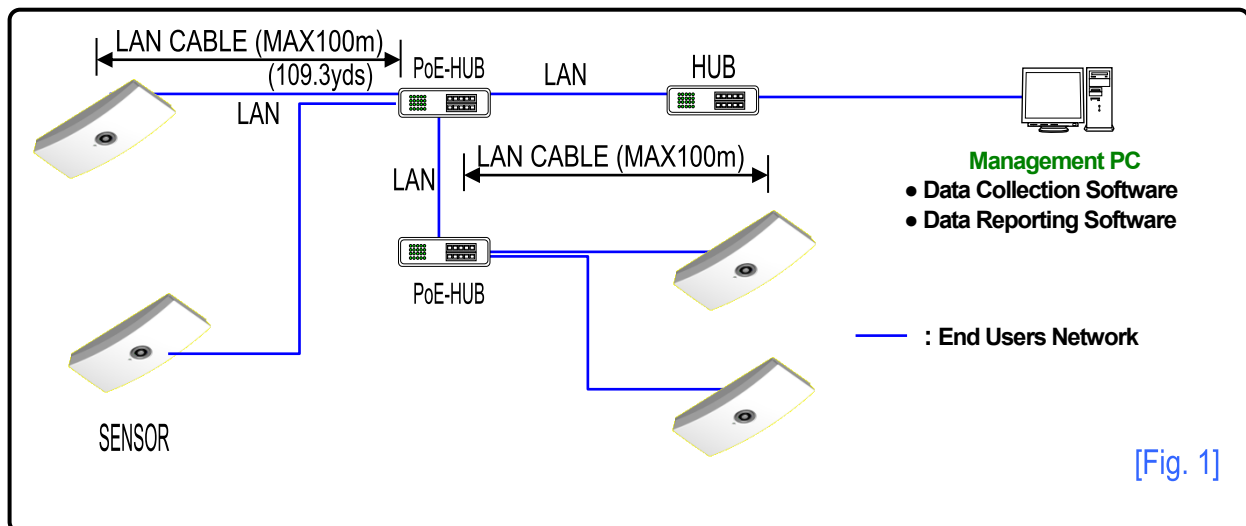

[Fig. 1]

Work details for System Installation

Item	Work Details	Remarks
1	Signal lines, Power lines, Wire laying work according to System Wiring Diagram	
2	SENSOR UNIT ceiling mount installation and wire connection work	
3	Connect LAN cable	
4	Locally purchase PoE HUB	
5	Data Collection, Reporting Software Installation	Data Collection, Reporting Software (if required)

3. AKRIBOS VC-1020 SENSOR UNIT INSTALLATION AND WIRING

■ Precautions

Please keep the SENSOR lens free from any dust or debris.

■ Installation Location Criterion

Install the SENSOR along the center of the door width, unless there is an object obstructing the center of the door width. (Refer to Fig. 2)

- 1) When installing the sensor at a corridor or passageway, install the sensor in the center, between the walls or pillars. (Refer to Fig. 3)
- 2) When installing 2 sensor units at 1 entrance (for wide entrances), divide the door width into two sections and install the sensors along the center of each divided section. (Refer to Fig. 7)

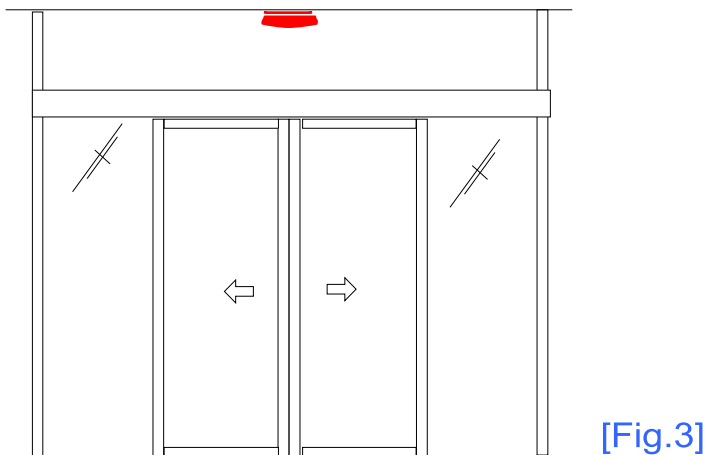
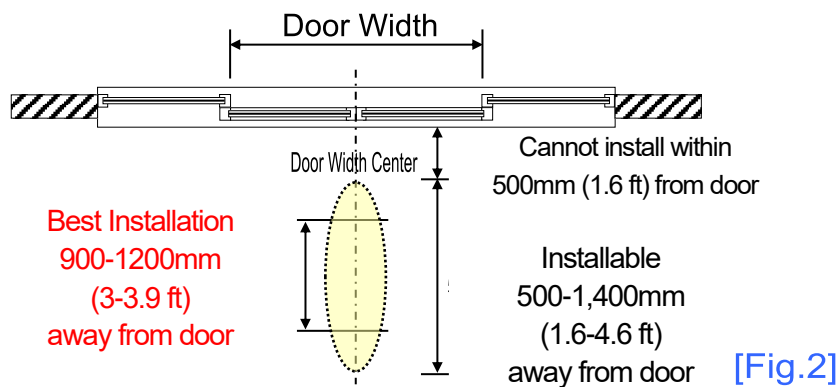

[Precautions for Installation Location]

If the sensors cannot be installed according to the criteria above, contact and check with our staff and install according to their directions.

Ex) Cannot install SENSOR at the door width center, or the SENSOR cannot be installed between the recommended 500-1400mm etc.

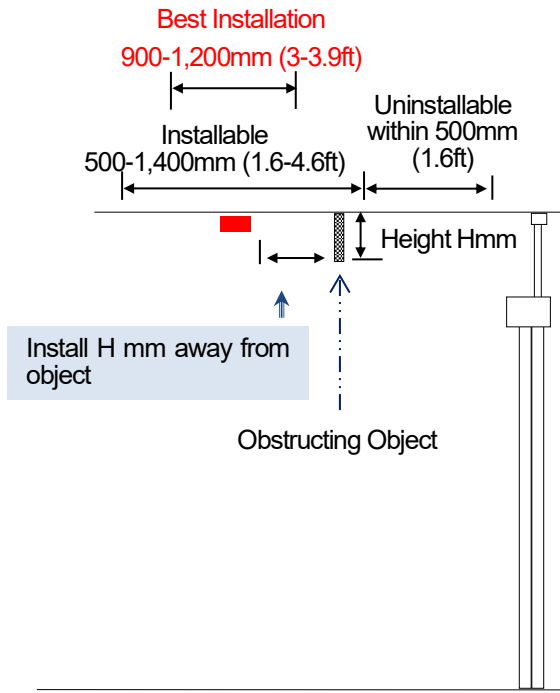

NOTE: When there is an obstructing object near the sensor, install the sensor the "same height as object" away from the object.

[Fig.4]

4. AKRIBOS VC-1020 SENSOR INSTALLATION LOCATION EXAMPLE

1) Installation Example for Passageway

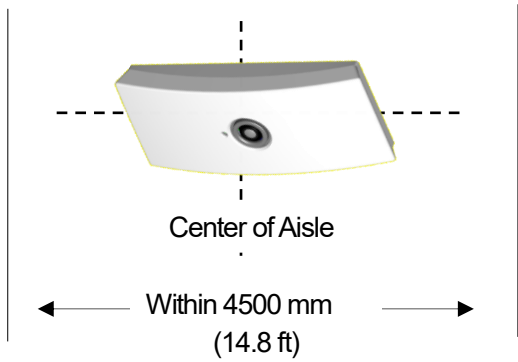

Center of Aisle

Within 4500 mm (14.8 ft)

*The drawing above illustrates a passageway between two walls with a ceiling height over 3,000mm (9.8 ft) and a width less than 4,500mm (14.8 ft) *When the installed height is less than 3,000mm the counting width will be less than 4,500mm.

[Fig.5]

2) Installation Example for Entrance/Passageway

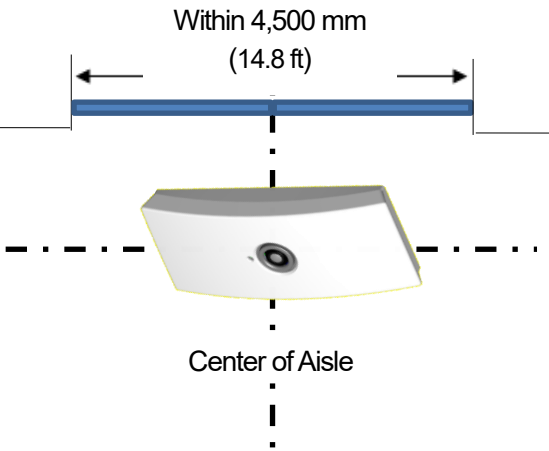

Within 4,500 mm (14.8 ft)

Center of Aisle

* The drawing above is an example of an entrance with a ceiling height over 3,000mm (9.8 ft) and a width of less than 4,500mm (14.8 ft).

[Fig.6]

3) Installation Example for Passageway (Installing 2 SENSORS)

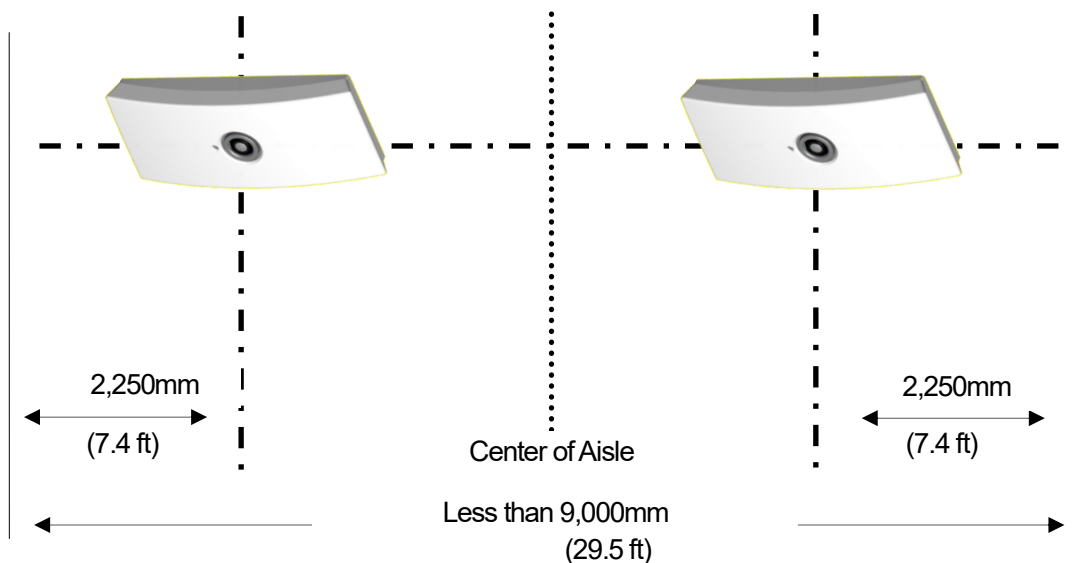

2,250mm (7.4 ft)

Center of Aisle

Less than 9,000mm (29.5 ft)

2,250mm (7.4 ft)

* The drawing above illustrates a counting area between two walls with a ceiling height of over 3,000mm (9.8 ft) and a counting width less than 9,000mm (29.5 ft).

* If the ceiling height is less than 3,000mm (9.8 ft), counting width is less than 4,500mm (14.8 ft).

[Fig.7]

*The counting width varies according to fitted heights.

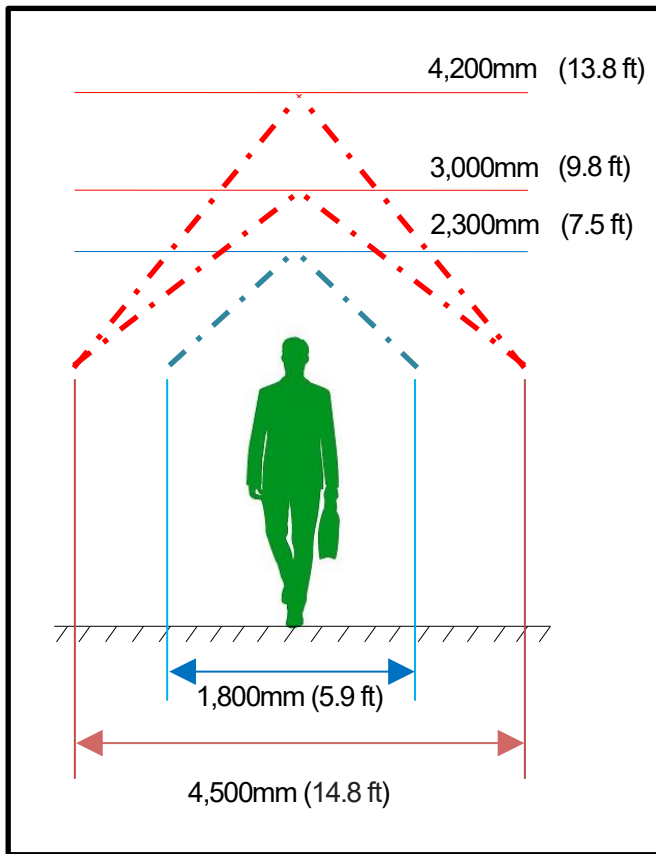

[Fig.8]

Ceiling height and Detection Area

Standard Mode

Ceiling Height	Detection Area
2,300mm (7.5 ft)	1,800mm (5.9 ft)
~	~
3,000mm to 4,200mm (9.8 ft – 13.8 ft)	4,500mm (14.8 ft)

High Mode

*When using high mode the detection area is smaller.

Ceiling Height	Detection Area
4,000mm (13.1 ft)	3,000mm (9.8 ft)
5,000mm (16.4 ft)	4,000mm (13.1 ft)
6,000mm (19.7 ft)	4,000mm (13.1 ft)

5. AKRIBOS VC-1020 SENSOR DESCRIPTION

Sensor Cover Attached

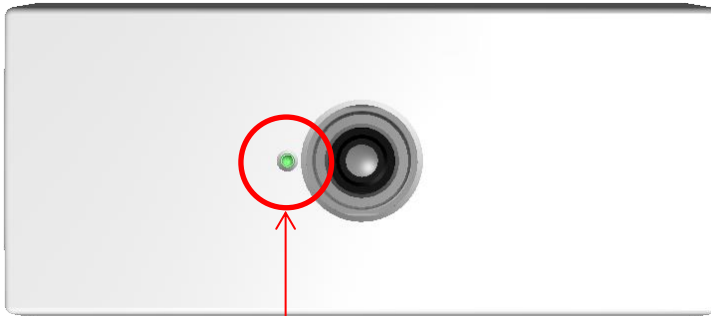

Operation LED

Initializing	:AMBER (When powered on will take 20 seconds to boot.)
Normal	:GREEN ON
IN Count	:RED FLASH
OUT Count	:GREEN FLASH
Power OFF	:DARK

Cover Removed

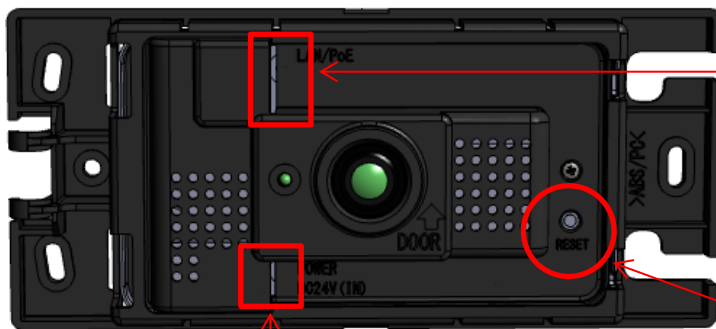

LAN / PoE Port

Power over Ethernet switching hub (PoE HUB) is connected via LAN cable.

DC Jack

AC adapter can be connected when a PoE is not used.

IP Address Reset Switch

*Registered IP address of the sensor can be initialized by holding down this switch for 5 seconds or longer.

Note: The default IP address is "192.168.0.249" / Subnet Mask is "255.255.255.0"

6. AKRIBOS VC-1020 SENSOR UNIT INSTALLATION

■ Removing the sensor unit cover

- 1) Insert your fingers in the location indicated in RED bottom of sensor and pull the cover from the unit. (Refer to [Fig. 9])
- 2) Completely remove the cover from the sensor unit. (Refer to [Fig. 10])

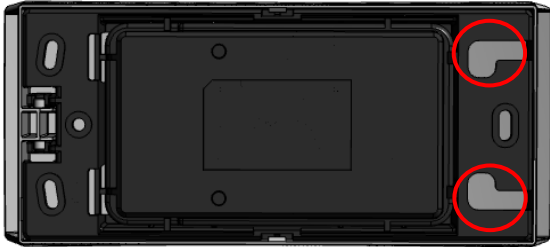

[Fig.9]

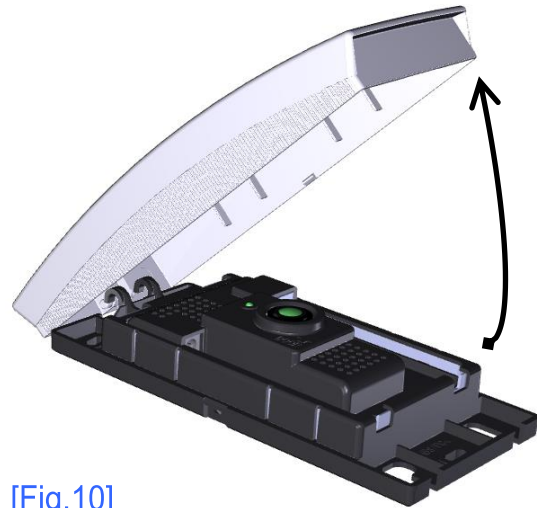

[Fig.10]

■ Wiring the sensor unit

- 1) Pull out the LAN cable (CAT5) from the sensor unit wire hole and cut the cable at the required length. Terminate the LAN cable with a RJ-45 connector. We recommend using solid single core wires.
Test the cable with a cable tester to ensure that the cable will function

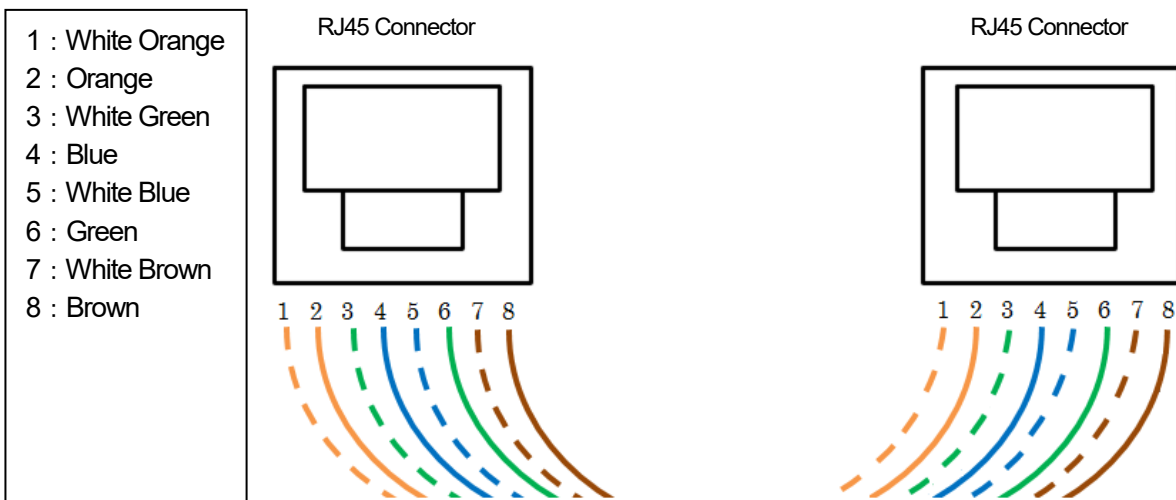

[Fig.11]

2) Connect the LAN cable. (Refer to [Fig.12])

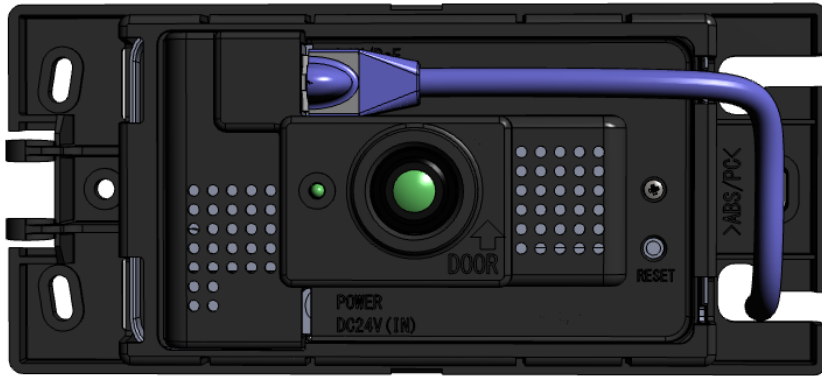

[Fig.12]

3) When supplying power from the power adapter without using PoE, insert the DC jack as indicated below.
(Refer to [Fig.13])

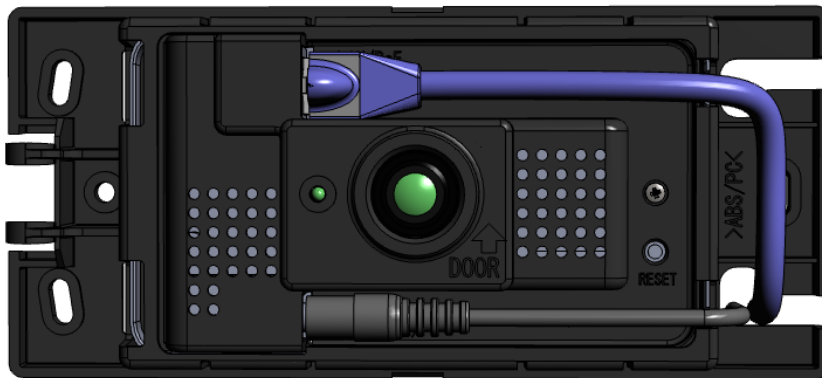

[Fig.13]

DC24 (DC Jack) max.7W

■ **Sensor Installation**

1) There is a specific sensor mounting direction.

The DOOR Indicator  on the sensor unit indicates the direction to install the sensor. Mount the sensor with the DOOR Arrow pointed towards the entrance.

The sensor can also be installed at areas without doors such as passageways, please install in the most suitable area in those cases. (Refer to [Fig. 14])

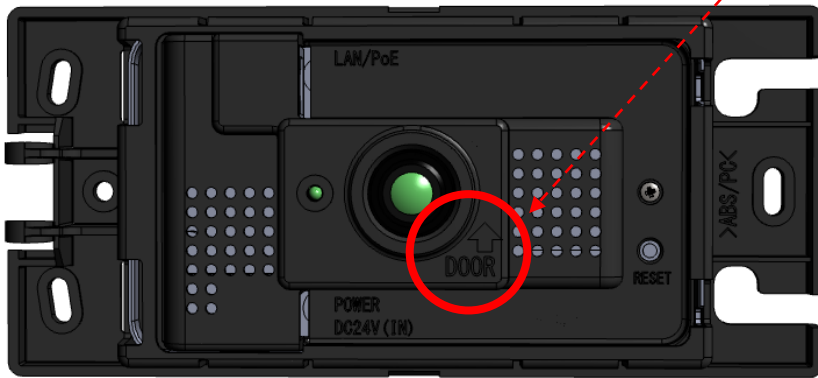
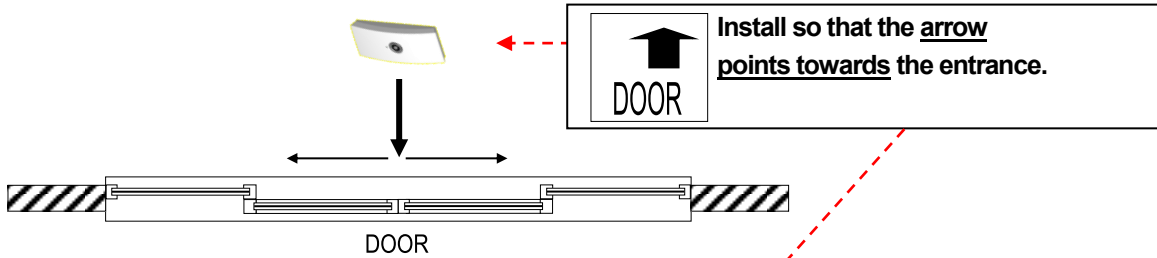

[Fig.14]

2) Secure the sensor unit to the ceiling at 3 points with screws (board anchors or suitable screw depending on ceiling material).



[Fig.15]

* Cables should be attached to the actual sensor unit. Omitted for explanation purposes.

■ Attaching the Sensor Cover

- 1) After securely fixing the sensor to the ceiling, reattach the cover. Hook the cover to the unit.
(Refer to [Fig. 16])

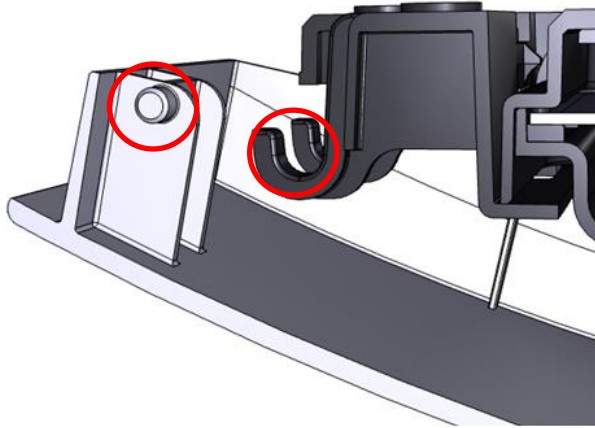

[Fig.16]

- (2) Attach the cover to the sensor unit. (Refer to [Fig. 17])



[Fig.17]

- (3) Push the cover up until it is secured to the unit. (Push the cover till it Clicks shut.) (Refer to [Fig. 18])

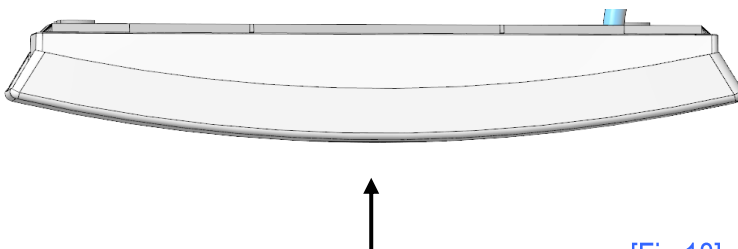

[Fig.18]

Sensor Installation work is complete.

7. AKRIBOS WEB SETTINGS

Do NOT connect the LAN cable to the END USERS network until the SENSOR UNIT network settings are completed.

■ Web Settings.

- (1) Connect PoE HUB (injector) to sensor unit. (Refer to Fig. 19)

Note: For some intelligent switches it may take a few minutes to establish connection.

- (2) Power up the sensor (will take 20 seconds to initialize)

While the sensor is initializing the LED will light AMBER, after the sensor is initialized the LED will turn on GREEN.

- (3) Connect the setup PC to sensor unit via PoE HUB (PoE injector)

*Setup PC requirements: Operating System (Windows VISTA or later) / Internet Explorer 8 or later.

*The sensor unit default IP address is "192.168.0.249". Please change the Setup PC network parameters to the same IP network range to enable communication between the setup PC and sensor (e.g. 192.168.0.250).

- (4) Setup the following network and sensor setup parameters.

Set the IP address, subnet mask, default gateway, port number and time settings, sensor mounting height, counting area, counting direction.

Please refer to "Web Settings Manual" for setup details.

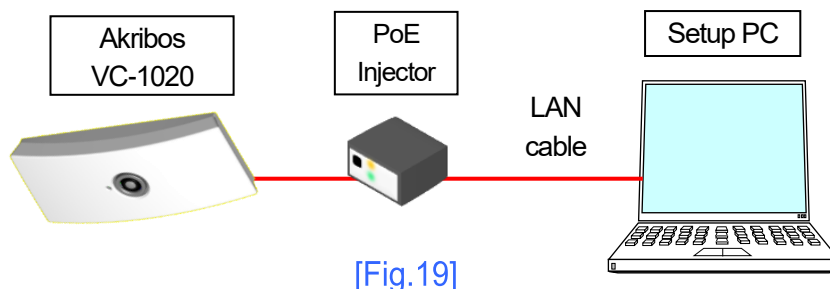

[Fig.19]

8. AKRIBOS CONNECT TO NETWORK

After completing the web settings, connect the LAN cable to end users network via PoE HUB.

(Please insert the LAN connector, until it clicks)

***Upon connecting the LAN, sensor connects the end user's network. Recheck the IP Address of the sensor, before connecting the network.**

9. AKRIBOS SENSOR UNIT Specifications

AKRIBOS (VC-1020) Specifications

Item	Specifications	Remarks
Dimensions	W : 193 mm (7.6inches) H : 85 mm (3.35inches) D : 34 mm (1.34inches)	Refer to [Fig. 20]
Installed Height	2,300mm to 4,200mm (7.5 to 13.8 ft)	High mode:4,000mm to 6,000mm (13.1 to 19.7 ft)
Power Source	DC48V (Max. 7W)	DC Jack: 24V
Cable Type	CAT5-UTP	
Wiring Distance	Distance to PoE HUB within 100m (109.3 yds).	
Connector	LAN connector	
LED Indicator	GREEN ON: Power ON (Normal) AMBER : Initializing (20 sec.) DARK : Power OFF	RED FLASH : IN GREEN FLASH: OUT

View

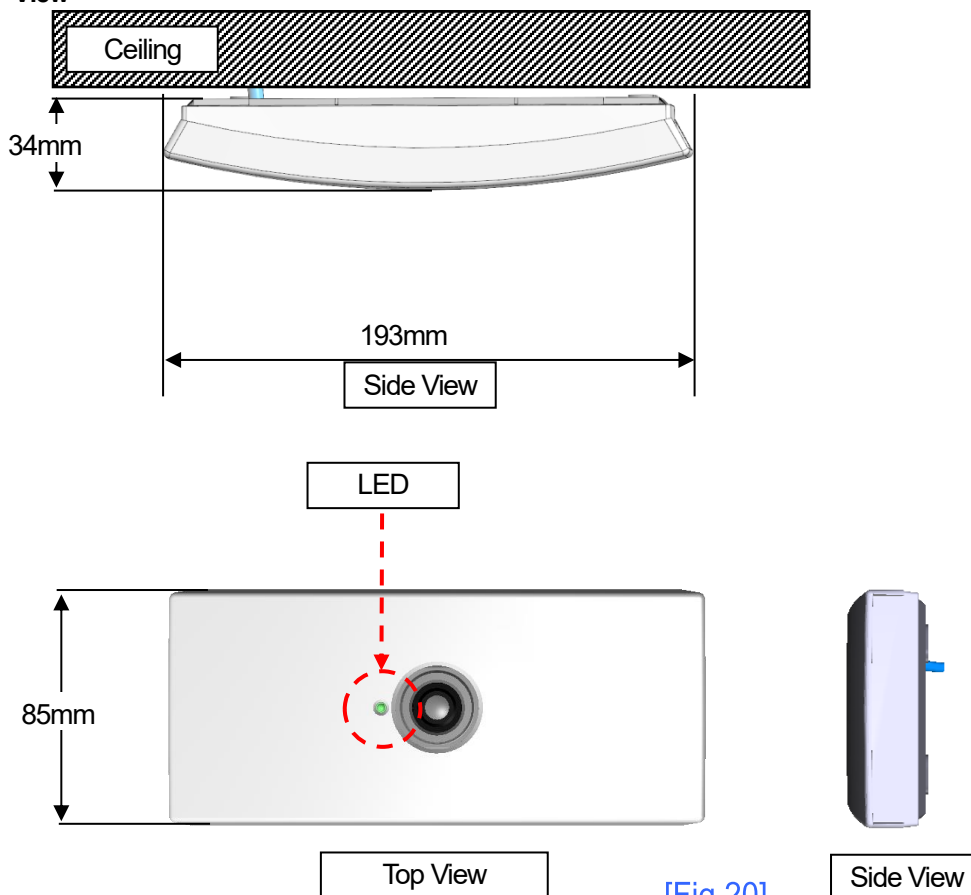

[Fig.20]

CONTACT DETAILS

DISTRIBUTOR

MANUFACTURER

GIKEN TRASTEM CO., LTD.

□Head Office 98 Takeda Nishi-Dankawara-cho Fushimi-ku Kyoto, Japan 612-8429
TEL : +81-75-646-5520 FAX : +81-75-646-2159
E-mail: mailpost@trastem.co.jp

! Operating Hours (Contact)

- Weekdays: AM 9:00 to PM 17:30 (GMT +9:00)
- Weekends/Holidays: Closed (Respond on next working day.)