

FC500IP

IP MODULE

INSTALLATION MANUAL



TABLE of CONTENTS

Overview	5
Component identification	5
Description of the indicator lights	5
Installation	5
Programming	5
View IP address	6
Technical features	6

To program IP Module FC500IP supplied with this manual, exclusively use the **FireClass500 Console** equipment version **1.1** or a higher version. BENTEL SECURITY does not accept any responsibility if the Control panel is handled by unauthorized personnel. The installation of IP Module FC500IP should be done in a state of the art mode, according to existing standards. IP Module FC500IP complies with the requirements of standards **EN54-2**, **EN54-4** and **EN54-21**.

The contents of this manual may be subject to changes without any former warning and does not represent any commitment on the part of BENTEL SECURITY srl.

Overview

The FC500IP is an IP Module which is used to connect control units in the FC500 range to a LAN.

The IP Module may be connected to a LAN using a private IP address or a DHCP address.

The same procedures may be performed using the FireClass500 console application, either through the serial port or the network. With a public IP address, it is also possible to manage and monitor the control unit from anywhere in the world, as long as you have access to the Internet.

⚠ Only one PC may be connected to the control unit at a time, via LAN or WAN. Any attempt to connect another PC to the same control unit will fail.

Component identification

Throughout the instruction manual, numbers in bold refer to the components identified in Figure 1 (this can be found at the end of the instruction manual). These components are described in the following table:

P.	Description
1	Terminal block for connections
2	Connector for control unit motherboard connection
3	Microprocessor
4	Connection speed indicator light (S): off = 10 Mbps; on = 100 Mbps
5	Connector for LAN connection
6	YELLOW indicator light for LAN traffic status
7	GREEN indicator light for LAN detection
8	IP Module status indicator light (L)
9	Fixing brackets
10	IP Module power supply cables
11	PC-Link cable
12	IP Module
13	Control unit motherboard
14	RS-232 serial port
15	IP Module screw anchor holes
16	Control unit base
17	Secure connector

Description of the indicator lights

The IP Module is equipped with the following indicator lights:

YELLOW light (6) This indicator light is located on the LAN connector (5) and provides a signal when traffic is detected between the IP Module and the LAN.

GREEN light (7) This indicator light is located on the LAN connector (5) and provides a signal when the LAN is detected:

➢ lit = LAN detected; off => LAN not detected.

S indicator light (4) Displays the LAN connection speed:

➢ off = 10 Mbps; ➢ lit = 100 Mbps.

L indicator light (8) Displays the events listed in the table below.

Pr.	Event	Flashes	Description
1	Low power	1	The IP Module power supply is too low (under 9.5 V)
2	LAN not detected	2	There is no connection between the IP Module and the hub or local router
3	Remote IP Module programming	10	The IP Module has been programmed via the LAN
4	Default settings	5	The IP Module is programmed using default settings. Follow the instructions provided in the paragraph "Initial programming" to end this event.

If one of the events listed in the above table occurs, the L indicator light flashes a number of times to correspond with the value given in the Flashes column, with an interval of 1 second.

If several events occur simultaneously, the L indicator light will signal the event with the greatest priority (see Pr. column in the above table).

The slow blinking (about every 5 sec.) of L indicator shows the normal operation of board.

Installation

The IP Module should be installed to the base of the control unit, as illustrated in Figure 1 (which can be found at the end of the instruction manual). Proceed as follows:

⚠ Before installing the IP Module, cut the control unit off from its power supply (it should be disconnected from the electricity mains and the batteries). If this is not possible, do not connect the IP Module power supply until the very end of the process: connect terminal [M] first, followed by terminal [+V].

1. Open the control unit as described in the corresponding set of instructions.
2. Fix the IP Module to the base of the control unit using the screws supplied, making sure it is correctly aligned with the screw anchor holes (15).
3. Connect connector 2 on the IP Module to the serial port on the control unit (14) using the PC-Link cable supplied (11).
4. Connect connector 5 to the LAN using an Ethernet cable.

⚠ Use a category 5 (or better) shielded Ethernet cable (STP or FTP).

5. Where present, connect the [OC] terminal to terminal block 1.
6. Connect terminals [+V] and [M] on terminal block 1 to the corresponding terminals [12 V] and [M] on the control unit motherboard (16).
7. Reconnect the control unit to the power supply.
8. Program the IP Module as described in the "Programming" paragraph.

Programming

Using the FireClass500 Console application.

This paragraph describes the parameters corresponding to the IP Module. For further information relating to the installation and operation of the FireClass500 Console application, programming procedures and any other parameters not described in this paragraph, please refer to the control unit INSTRUCTION MANUAL.

The parameters corresponding to the IP Module may be selected and programmed via the IP Module screen as described below.

■ IP Module screen

The IP Module screen is used to program the parameters corresponding to the IP Module as described below.

Retrieve information from ... This section is used to set the parameters required for communication with the IP Module.

➢ **IP address** – Enter the IP address assigned to the IP Module you wish to program or, if DHCP (dynamic IP address) mode has been selected, contact the network administrator to request details of the IP address assigned to the IP Module. Alternatively, follow the procedure outlined in the "View IP address" paragraph to view the IP address on the control unit display.

The default setting is 192.168.0.101.

➢ **IP Module port** – Enter the details of the port assigned to the IP Module you wish to program (contact the network administrator).

The default setting is 3064.

➢ **IP Module code** – Enter the access code assigned to the IP Module you wish to program. The default setting is 5555.

➢ **Encryption key** – Enter the encryption key assigned to the IP Module you wish to program.

The default setting is 32 zeros.

Procedure The Procedure section separates the buttons into groups in order to carry out certain procedures (described below) for the connected IP Module (see "Retrieve information from...").



Upload from IP Module – Select this button to upload the settings programmed on the connected IP Module.



Send to IP Module – Select this button to send the settings from the screen to the connected IP Module.



Default settings – Select this button to restore the default settings of the connected IP Module.



Update firmware – Select this button to update the firmware for the connected IP Module.

IP address This section is used to set the parameters corresponding to the IP address.

- **DHCP** – Select this option if you wish to use a dynamic address for the IP Module you are programming.
- **Manual settings** – Select this option if you wish to assign a static IP address to the IP Module you are programming, then set the following parameters:
 - **IP address:** enter the IP address to be assigned to the IP Module; the network administrator will provide you with this information. The default setting is 192.168.0.101.
 - **Subnet mask:** this must be the same as the subnet mask for the local network; only one subnet mask is valid for each local network. All nodes on the same subnet will use the same subnet mask; the network administrator will provide you with this information. The default setting is 255.255.0.0.
 - **Gateway IP address:** enter the IP address of the local gateway which may be used by the IP Module to connect to a PC outside the LAN (WAN). The default setting is 0.0.0.0.

General options This section is used to select the general options for the IP Module.

- **Encryption key** – If it has been programmed, the IP Module will use this key to encode and decode the packets exchanged with the PC. The encryption key may include between 1 and 32 hexadecimal characters. To disable encryption, enter 0 (zero). If the encryption key does not correspond to that of the IP Module, communication between the PC and the IP Module will NOT be permitted. The default setting is 0 (encryption key not enabled).
- **IP Module port** – This is the port which should be used to communicate with the IP Module. The default setting is 3064.
- **Control unit port** – This is the port which should be used to communicate with the control unit. The default setting is 3062.
- **IP Module code** – This code should be applied when the FireClass 500 Console is used to program the IP Module, either remotely or locally. The code should consist of 4 hexadecimal digits. The default setting is 5555.
- **Timeout due to connection with no traffic** – Enter the maximum time period during which no data is transmitted before the connection is terminated. The default setting is 20 seconds.

Events mask This section can be used to enable/disable signals from the OC output and the indicator light L (8), for certain events recognised by the IP Module: **LAN not detected**, **Remote IP Module programming**, **Local IP Module programming** (see paragraph "Description of the indicator lights" for a description of these events). A tick indicates that the corresponding event will be signalled! The LAN not detected event indication is enabled by default.

Read-only options The values in this section cannot be modified. They display information relating to the connected IP Module.

- **MAC Address** – Displays the MAC address of the IP Module: the MAC address is a unique identification number assigned to every IP device throughout the world.
- **Software version** – Displays the version of the program running on the IP Module.
- **Boot version** – Displays the boot version.
- **Current IP address** – Displays the IP address assigned to the IP Module.

Ethernet speed This section is used to set the parameters corresponding to the Ethernet interface of the IP Module: the Auto setting is selected by default.

- **Auto** – If this option is enabled, the IP Module will take the speed and duplex values from the network. If this option is disabled, the speed and duplex values must be set as described below.
- **Speed** – If the Auto option is disabled, set the speed value as appropriate: **10 Mbps** or **100 Mbps**.
- **Duplex** – If the Auto option is disabled, set the Data exchange (Duplex) mode as appropriate: **Half** or **Full**.

Output polarity This section is used to set the operating mode of the OC output on the IP Module.



- **Open on breakdown** – The outlet is suspended when a breakdown occurs (default setting).
- **Close on breakdown** – The output is connected to the earthing system when a breakdown occurs.

Recycling warning

BENTEL SECURITY advises its clients to dispose of used devices (control panels, detectors, sirens, electronic accessories, etc.) with full respect towards the environment. Methods which could be used include the re-use of parts or of whole products and the recycling of products, components and/or materials. For further information visit: www.bentelsecurity.com/it/ambiente.htm

Initial programming

To program the IP Module for the first time, a LAN consisting of the IP Module and the PC must be created and an IP address set for the latter, such as the default IP Module value (192.168.0.101). Proceed as follows:

1. Disconnect the network cable from the PC., if present.
 2. Connect the IP Module to the PC using a network cable.
 3. Change the IP address of the PC to 192.168.0.XXX (see below).
 4. Start the FireClass 500 Console application.
 5. Set the IP address of the IP Module to an address which is valid for the network to which it will be connected.
- 
6. Select the button  (Send to IP Module); make sure that the **IP Module code** is 5555.
 7. Restore the original IP address of the PC (see below).
 8. Reinstall the original wiring and connect the FC500IP to the established network.

Changing the IP address of the PC. For Windows 98 or later versions, proceed as follows:

1. Open the network connection properties window.
2. Select the **Internet Protocol (TCP/IP)** tab.
3. Select the **Properties** button: The **Properties – Internet Protocol (TCP/IP)** window will be opened.
4. Enable the option **"Use this IP address"**.
5. Enter the value 192.168.0.XXX in the **IP address** box (with XXX other than 101). Once the IP Module programming is complete, restore the IP address of the PC using the same procedure.



Restore default settings

The default settings may be restored as described below.

⚠ When the default settings are restored, it will NO LONGER be possible to communicate with the IP Module and the control unit via the LAN; communication will only be possible using the procedure described in the paragraph "Initial programming"

Via software Select the button  (Default settings) on the IP Module screen.

Via hardware Proceed as follows:

1. Disconnect the IP Module from the power supply: disconnect terminal [+V] on terminal block 1.
2. Disconnect the PC-Link cable (11) from connector 2.
3. Short-circuit the first two terminals on connector 2, marked with the symbol .
4. Restore the IP Module power supply (reconnect the [+V] terminal on terminal block 1) while keeping the terminals  on connector 2 short-circuited, until the S indicator light (4) begins to flash.
5. Reconnect the PC-Link cable (11) to connector 2.

View IP address

The IP address assigned to the IP Module may be viewed on the control unit display. To do so, proceed as follows:

1. Press **F2** (Analyze)
2. Press button **6** (Communic.) the firmware version (**FW ver**) and IP address (**ADDR**) of the IP Module will appear on the display (watch the line marked with 1 on the display).

Technical features

Power supply	13,8 ÷ 27,6 V $\overline{=}$
Max. absorption	250 mA
Resting absorption	50 mA
Operating temperature	-5 ÷ +40 °C
Dimensions L *H)	93*65 mm

Waste Electrical and Electronic Equipment Directive (RAEE – WEEE)



Within the European Union, this label indicates that this product should NOT be disposed of along with domestic refuse. It should be placed in a suitable bin from where it would be possible to perform recovery and recycling operations. For further information visit: www.bentelsecurity.com/it/ambiente.htm

NOTES

This product uses the FreeRTOS.org real time kernel.
 The FreeRTOS.org source code can be obtained by visiting
<http://www.FreeRTOS.org>

FreeRTOS LICENSING

"The FreeRTOS source code is licensed by the GNU General Public License (GPL) with an exception.

The full text of the GPL is available here:

<http://www.freertos.org/license.txt>

The text of the exception is available on FreeRTOS official website:

<http://www.FreeRTOS.org> – License and Warranty Page

The exceptions permits the source code of applications that use FreeRTOS solely through the API published on this WEB site to remain closed source, thus permitting the use of FreeRTOS in commercial applications without necessitating that the whole application be open sourced. The exception should only be used if you wish to combine FreeRTOS with a proprietary product and you comply with the terms stated in the exception itself."

This product contains software which include the lightweight IP (lwIP) networking stack that was originally written by Adam Dunkels of the Swedish Institute of Computer Science but now is being actively developed by a team of developers distributed world-wide, which has been incorporated under the following license.

LwIP LICENSING:

"lwIP is licenced under the BSD licence:

Copyright (c) 2001-2004 Swedish Institute of Computer Science.
 All rights reserved.

Redistribution and use in source and binary forms, with or without modification, are permitted provided that the following conditions are met:

1. Redistributions of source code must retain the above copyright notice, this list of conditions and the following disclaimer.
2. Redistributions in binary form must reproduce the above copyright notice, this list of conditions and the following disclaimer in the documentation and/or other materials provided with the distribution.
3. The name of the author may not be used to endorse or promote products derived from this software without specific prior written permission.

THIS SOFTWARE IS PROVIDED BY THE AUTHOR "AS IS" AND ANY EXPRESS OR IMPLIED WARRANTIES, INCLUDING, BUT NOT LIMITED TO, THE IMPLIED WARRANTIES OF MERCHANTABILITY AND FITNESS FOR A PARTICULAR PURPOSE ARE DISCLAIMED. IN NO EVENT SHALL THE AUTHOR BE LIABLE FOR ANY DIRECT, INDIRECT, INCIDENTAL, SPECIAL, EXEMPLARY, OR CONSEQUENTIAL DAMAGES (INCLUDING, BUT NOT LIMITED TO, PROCUREMENT OF SUBSTITUTE GOODS OR SERVICES; LOSS OF USE, DATA, OR PROFITS; OR BUSINESS INTERRUPTION) HOWEVER CAUSED AND ON ANY THEORY OF LIABILITY, WHETHER IN CONTRACT, STRICT LIABILITY, OR TORT (INCLUDING NEGLIGENCE OR OTHERWISE) ARISING IN ANY WAY OUT OF THE USE OF THIS SOFTWARE, EVEN IF ADVISED OF THE POSSIBILITY OF SUCH DAMAGE."

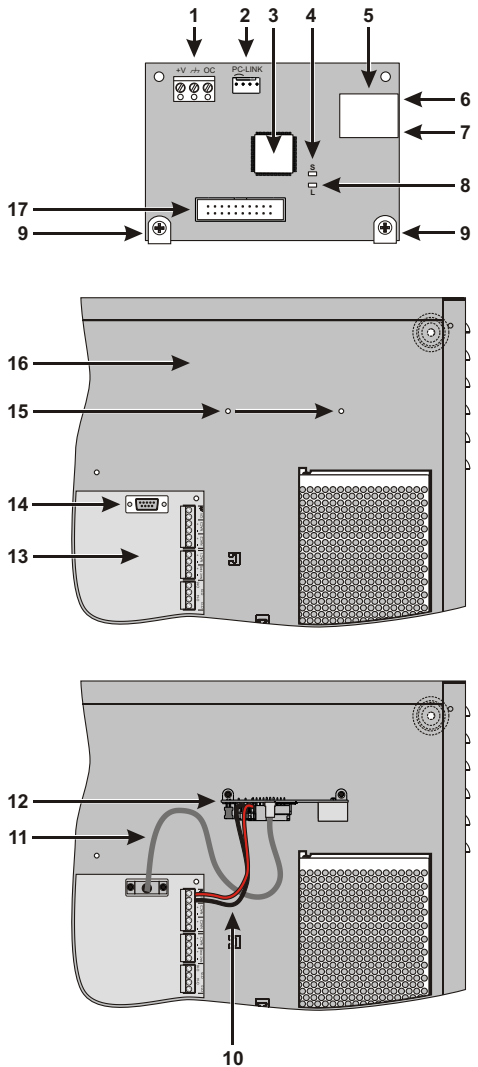

Figure 1 Parts Description and Installation of IP Module

P.	Description
1	Terminal block for connections
2	Connector for control unit motherboard connection
3	Microprocessor
4	Connection speed indicator light (S): off = 10 Mbps; on = 100 Mbps
5	Connector for LAN connection
6	YELLOW indicator light for LAN traffic status
7	GREEN indicator light for LAN detection
8	IP Module status indicator light (L)
9	Fixing brackets
10	IP Module power supply cables
11	PC-I ink cable
12	IP Module
13	Control unit motherboard
14	RS-232 serial port
15	IP Module screw anchor holes
16	Control unit base
17	Secure connector