

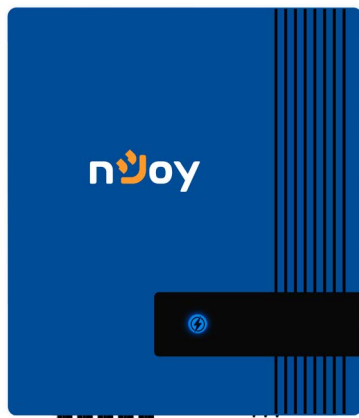

Astris 3Phase

User Manual

Manual de utilizare



319.9.23.0

Before using this product, carefully read all product documentation and retain it for future reference.

Forward	1
Symbol Conventions	2
Safety	2
1.1 Symbols Used	3
1.2 Safety Precaution	3
Product Introduction	5
2.1 Overview	5
2.2 Model Definition	5
2.3 Product Appearance	6
Upack and Storage	8
3.1 Upack and Check	8
3.2 Storage Inverter	9
3.3 Identify Inverter	9
Installation	10
4.1 Selecting the Mounting Location	10
4.2 Mounting	14
Electrical Connection	16
5.1 Grounding	16
5.2 AC Connection	18
5.3 DC Connection	20
5.4 Communication Connection	23
Startup/Shutdown Procedure	27
6.1 Check before startup/shutdown Procedure	27
6.2 Startup Procedure	27
6.3 Shutdown Procedure	28
User Interface	29
Troubleshooting and Maintenance	33

8.1 Troubleshooting	34
8.2 Maintenance	38

Please read this manual before using the product.

It is addressed to the following models:

SIN320050002ATCU0B - Astris 5K /3P2T2

SIN320060002ATCU0B - Astris 6K /3P2T2

SIN320080002ATCU0B - Astris 8K /3P2T2

SIN320100002ATCU0B - Astris 10K /3P2T2

SIN320100003ATCU0B - Astris 10K /3P2T3

SIN320120003ATCU0B - Astris 12K /3P2T3

SIN320150003ATCU0B - Astris 15K /3P2T3

SIN320150004ATCU0B - Astris 15K /3P2T4

SIN320170004ATCU0B - Astris 17K /3P2T4

SIN320200004ATCU0B - Astris 20K /3P2T4

SIN320220004ATCU0B - Astris 22K /3P2T4

SIN320250004ATCU0B - Astris 25K /3P2T4

This user manual introduces the inverter in terms of its installation, electrical connections, operation, commissioning, maintenance, and troubleshooting. Please read through the manual carefully before installing and using the inverter, and keep the manual well for future reference.

Preface

About This Manual





This manual describes the installation, electrical connection, commissioning and maintenance, APP operation of the inverter. Please first read the manual and related documents carefully before using the product and store it in a place where installation, operation and maintenance personnel can access it at any time. The illustration in this user manual is for reference only. This user manual is subject to change without prior notice.

Target Group

Inverters must be installed by professional electrical engineers who have obtained relevant qualifications.

Symbol Conventions









The following safety instructions and general information are used within this user manual.

Symbol	Description
 DANGER	Indicates an imminently hazardous situation which, if not correctly followed, will result in serious injury or death.
 WARNING	Indicates a potentially hazardous situation which, if not correctly followed, could result in serious injury or death.
 CAUTION	Indicates a potentially hazardous situation which, if not correctly followed, could result in moderate or minor injury.
 NOTICE	Indicates a potentially hazardous situation which, if not correctly followed, could result in equipment failure, or property damage.
 NOTE	Calls attention to important information, best practices and tips: supplement additional safety instructions for your better use of the PV inverter to reduce the waste of your resource.

1 Safety

Before using the inverter, please read all instructions and cautionary markings on the unit and manual. Put the instructions where you can take them easily. The inverter of us strictly conforms to related safety rules in design and test. Local safety regulations shall be followed during installation, operation and maintenance. Incorrect operation work may cause injury or death and damage to the inverter and other operator or a third party. To avoid injury and damage to the inverter and other operator, please follow the safety precautions.

1.1 Symbols Used

Symbol	Description
	Danger of high voltage and electric shock! Only qualified personnel may perform work on the inverter.
	Danger of high voltage. Residual voltage in the inverter need 5 mins to discharge, wait 5 mins before operation.
	Danger of hot surface
	Fire danger
	Environmental Protection Use Period
	Refer to the operating instructions
	Product should not be disposed as household waste
	Grounding terminal

1.2 Safety Precaution

- Installation and maintenance of inverters must be performed by qualified personnel, in accordance with local electrical standards, wiring regulations and requirements of local power authorities.
- To avoid electric shock, DC input and AC output of the inverter must be terminated at least 10 minutes before performing any installation or maintenance.

- The temperature of some parts of the inverter may exceed 60°
- during operation,do not touch the inverter during operation to avoid being burnt.
- Ensure children are kept away from inverters.
- Don't open the front cover of the inverter. Apart from performing work at the wiring terminal, touching or changing components without authorization may cause injury to people, damage to inverters and annulment of the warranty ropriate measures to avoid electric shock.
- Ensure the output voltage of the proposed PV array is lower than the maximum rated input voltage of the inverter; otherwise the inverter may be damaged and the warranty annulled.
- When exposed to sunlight, the PV array generates dangerous high DC voltage. Please operate according to our instructions,or it will result in danger to life.
- Don't insert or pull the terminals when the inverter is running.

2 Product Introduction

2.1 Overview

The three-phase grid-tied PV inverter converts the DC generated by PV panels into three-phase alternating current and is delivered to the grid. This series inverter is an important part of PV system and it is suitable for household use, commercial use, fishery use, agricultural use and other scenarios.

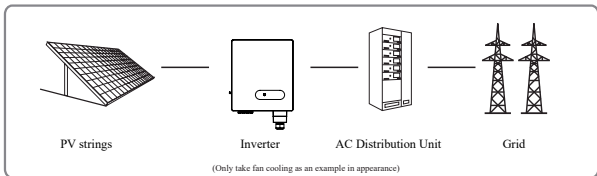

This series inverter is suitable for TN-S, TN-C, TN-C-S and TT grid system. Refer to the following figures:

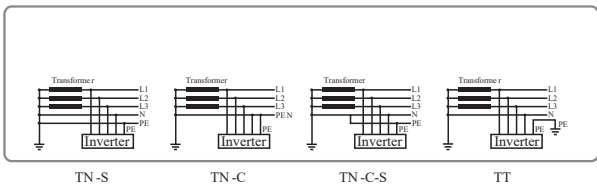

2.2 Model Definition

Model number descriptions (using Astris 10K/3P2T2 as an example):

10K/3P2T2



3 Phase (3P)

Output Power (10KW)

2.3 Product Appearance

The following is only for reference, specific please in kind prevail

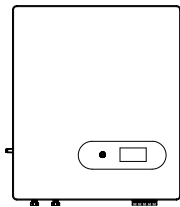
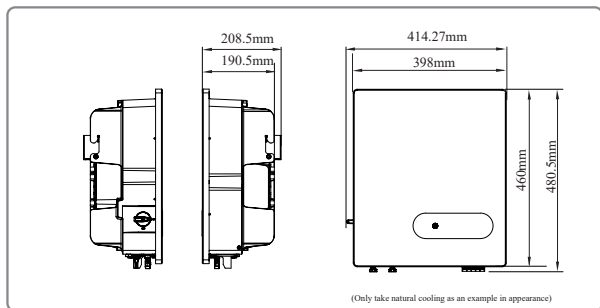

Natural cooling series

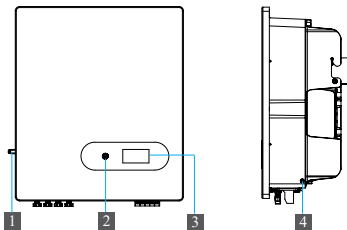

Fan cooling series

Description	Description
1	DC Switch
2	LED Indicators
3	LCD Screen (Optional)
4	External ground terminal

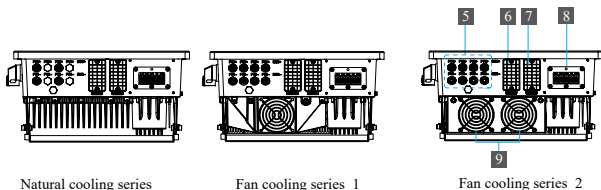

Description	Description
5	PV terminal
6	RS485 communication port
7	WiFi/GPRS/LAN model communication port (Optional)
8	AC output port
9	External fan (It is only suitable for Fan cooling series)

3 Upack and Storage

3.1 Upack and Check

Complete test and strict inspection shall be done before the inverter is sent out. When receiving the inverter, check that the packing materials are intact. After unpacking, examine the PV inverter and its fittings for damage and check that the deliverables are complete.

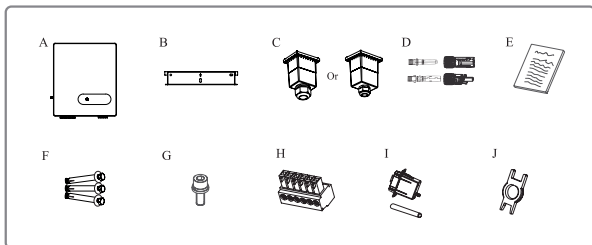

Number	Description	
A	The Inverter	1
B	Bracket	1
C	AC shield (4× M4 security screws)	1
D	PV connectors	2 or 4
E	File package	1
F	Expansion screws groups	3
G	M6 Security screw	2
H	6-Pin terminal	1
I	WiFi/GPRS module (Optional)	1 (Optional)
j	Remove tool for PV connector	1 (Optional)



NOTICE

Contact your dealer immediately if there is any issue found during operation.

3.2 Storage Inverter

If the inverter is not used immediately, please keep the inverter in a specific environment according to the following requirements.

- Do not unpack the inverter and put desiccant in the original box if the PV inverter is unpacked.
- Store temperature range: $-25^{\circ}\text{C}\sim+60^{\circ}\text{C}$; Relative humidity range: 0~100%.
- Don't position the inverter leaning forward, excessively leaning backward, tilting laterally, or upside down.
- Ensure that qualified personnel inspect and test the inverter before use if it has been stored for a long time

3.3 Identify Inverter

Inverter body label. The following is only for reference, specific please in kind prevail!

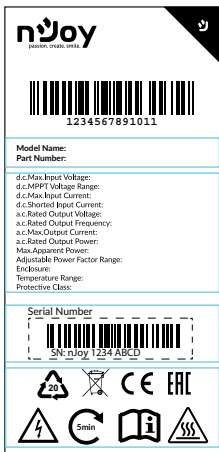

Number	Description
1	Product name and model
2	Product technical parameters
3	SN Barcode
4	Approve and Safety identification

4 Installation

After checking the outer packing, move the PV inverter to the designated installation position horizontally.

CAUTION

1. Please place the inverter horizontally on the foam or other soft pads and ensure that the ports are free of load-bearing pressure to avoid inverter damages or scratches.
2. The inverter is heavy, be careful to prevent the inverter from slipping and hurting the operator when moving the inverter.

DANGER

Ensure there is no electrical connections around ports of the PV inverter before installation.

4.1 Selecting the Mounting Location

4.1.1 Installation Environment Requirements

- a. The storage inverter protection class is IP65 and can be mounted indoors or outdoors.
- b. To ensure optimum operation and long service life, the ambient temperature must be below 50°C.
- c. Do not install the inverter in a rest area since it will cause noise during operation.
- d. The inverter carrier must be fire-proof. Do not mount the inverter on flammable building materials.
- e. Ensure that the wall meets the requirements of the inverter installation
- f. Product label and warning symbols shall be clear to read after installation
- g. The installation height should be reasonable and make sure it is easy to operate and view the display.
- h. Please avoid direct sunlight, rain exposure, snow lay up.

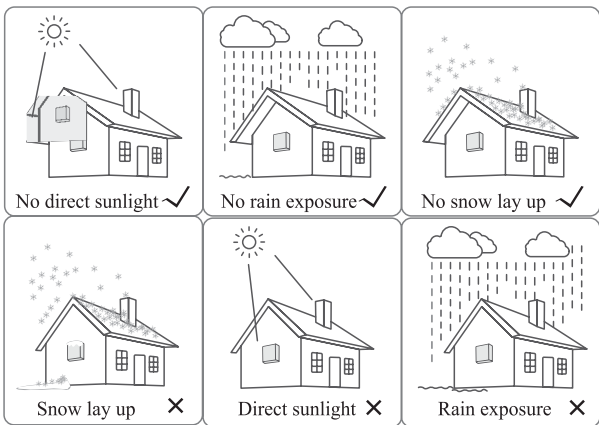

4.1.2 Mounting Requirements

Mount the inverter vertically or tilted backward by max 15°. In order to facilitate the heat dissipation of the inverter

NOTICE

The wrong installation mode causes the inverter to be damaged or unable to work properly.

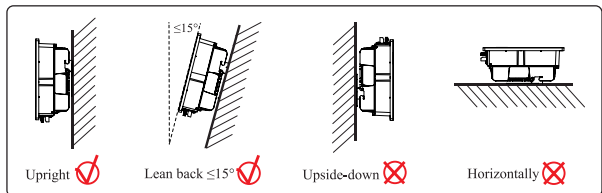

4.1.3 Installation Space Requirements

To ensure the operation of the inverter normally and easily, there are requirements on available spaces of the inverter, e.g. to keep enough clearance. Refer to the following figures.

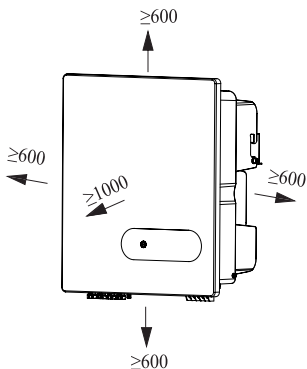

Above: 600mm

Below: 600mm

Front: 1000mm

Both sides: 600mm

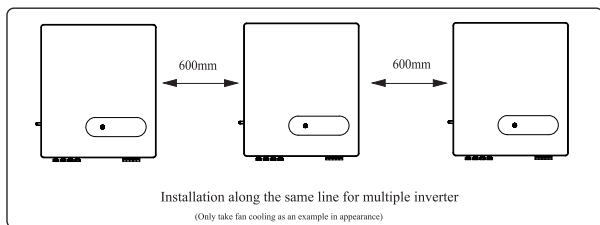

Installation perspective schematic

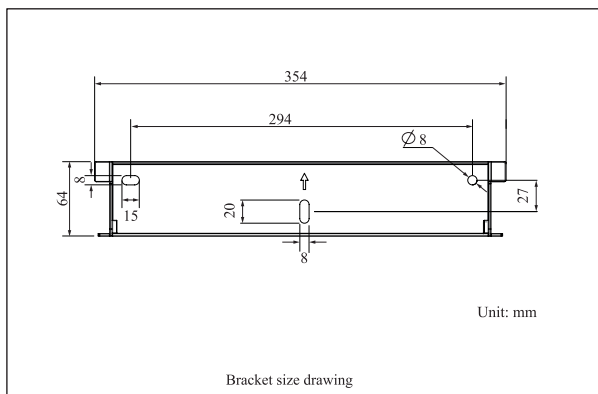
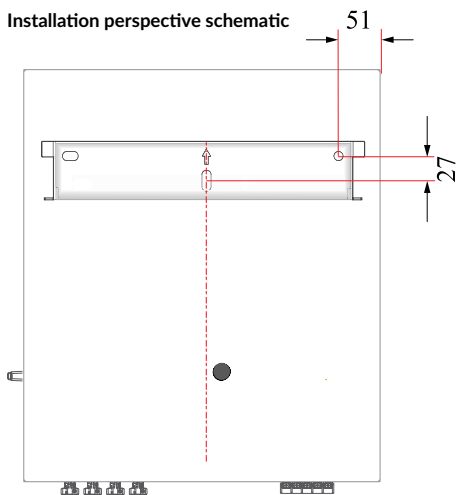

4.2 Mounting

Step 1. Install the mounting bracket

DANGER

- 1.The walls must be fireproof and non-flammable materials,otherwise there is a fire risk.
- 2.Before drilling holes ,check whether there are electric power pipes buried in the walls to avoid risks.

1) Use a horizontally ruler to mark the position of the 3 holes on the wall. Refer to Step 1. And drill 3 holes, 10mm in diameter and 60 mm in deep. Refer to Step 1 and Step 2.

2) Knock the expansion screw kit into the hole together with a hammer. Refer to Step 3.

Note: Do not remove the nut unit.

3) After tightening 2-3 buckles, the expansion bolts are tight and not loose, and then unscrew the bolts, spring washer, gasket. Refer to Step 3.

4) Install the bracket on the wall,the bracket screw is pointed at the expansion tube on the wall, then install the gasket and tighten screw. Refer to Step 4.

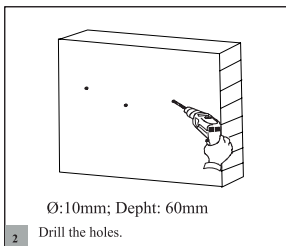
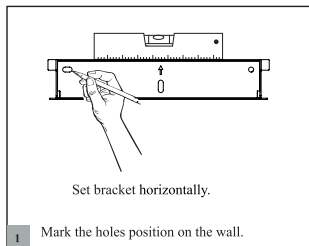

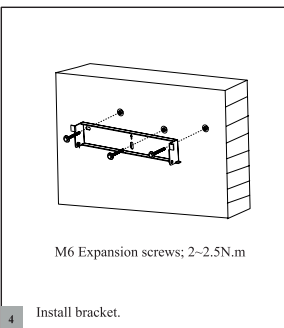
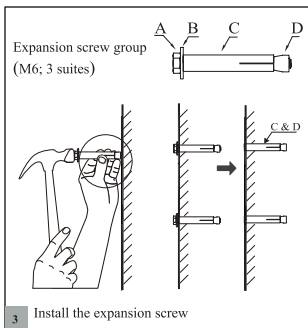

Step 2. Install the inverter.

Install the inverter on the bracket accurately and tighten the screws at both sides, as shown in Step 5 and Step 6.



CAUTION

To prevent damage of the inverter, please hang the inverter on the bracket and confirm the reverse, do not loosen the handle until the inverter is fixed

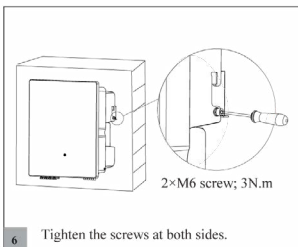
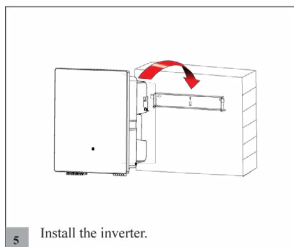

5 Electrical Connection

System Connection

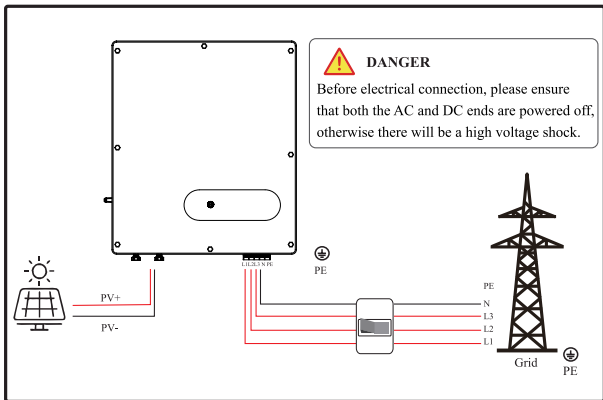

5.1 Grounding

According to the EN50178 requirement, the right side of the device has a protective grounding connection. Be sure to connect the protection ground cable to this port when installing the inverter. The user can perform the ground connection according to the on-site condition

Step1. Remove an appropriate length using a wire Stripper.

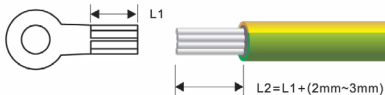

Step2.Insert the exposed core wires into the crimping areas of the OT terminal and crimp them using hydraulic pliers.

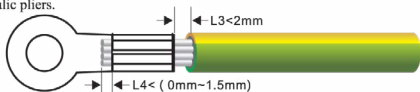

Step3.Remove the ground screws from the ground points.

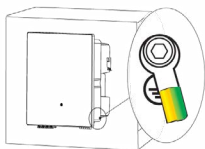

Items	Remark
Screw	M6 × 12mm; 3 N.m
OT Terminal	OT6-6(5K-15K); OT16-6(17K-25K)
Yellow green lines	$S_{\text{Yellow green lines}} \geq S_{\text{PE line of DC cable}}$ S is the cross-sectional area.
Ensure that the grounding resistance is less than 10Ω.	



WARNING

According to regulations, the secondary protection grounding can't replace the PE terminal connection of the AC cable. Ensure that both are grounded reliably. Otherwise, fatal injury can occur due to the high voltage.



CAUTION

If the positive pole or negative pole of the PV array is required to be grounded, then the inverter output (to AC grid) must be isolated by transformer in accordance with IEC63109-1,-2 standards.

5.2 AC Connection

5.2.1 AC cable connection

1. Measure and access the voltage and frequency of the point to ensure that it meets the grid-tied specifications of the inverter.
2. PE wire(GND) must be well grounded to ensure that impedance between Neutral wire and Earth wire is less than 10 Ω .
3. Disconnect the circuit breaker or fuse from the inverter and grid-connected access point.
4. Use the copper wire.
5. Follow these steps.

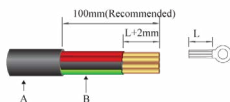

No.	Name	Model	5K-15K	17K-20K	22K-25K
A	Wire outer diameter(mm)		11-18	24-32	24-32
B	Cross-sectional area(mm ²)	Range	4-6	6-16	10-1
		Recommended	6	10	16

Note: It is recommended to use outdoor dedicate cables with multiple copper cores.

- 1 Select proper AC cables and OT terminals (5 wires)

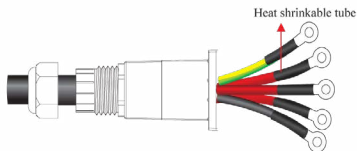

Unscrew the nut of the cover and thread the AC cable (5 wires) cross the nut, threaded sleeve and the cover. Then crimp the OT terminal and use heat shrink tubing or insulation tape for protection.

- 2 Wires threading and pressing.

- 3 Lock the AC cable to the corresponding AC terminals.

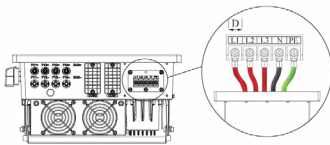

(Only take 25K model as an example)

	Screw	Torque	D
5K-15K	M4	1.5N.m	10mm
17K-25K	M5	3N.m	12.5mm

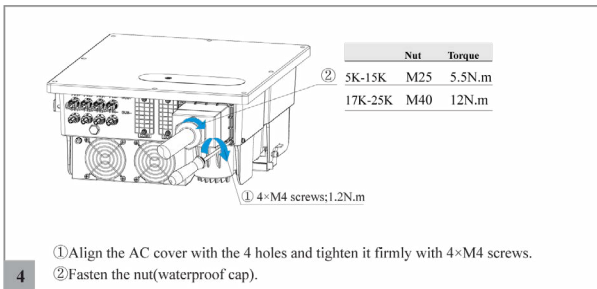

5.2.2 AC Breaker and Leakage current protector

To ensure that the inverter disconnect from the grid of safely, the independent AC breaker must be configured for each inverter as a protective device.



WARNING

- Multiple inverters are not allowed to share a circuit breaker.
- Load is not allowed to connect between the inverter and the AC breaker.

Inverter Model	Recommended Value
Astris 5K/3P2T2, Astris 6K/3P2T2, Astris 8K/3P2T2	20A
Astris 10K/3P2T2, Astris 10K/3P2T3, Astris 12K/3P2T3	32A
Astris 15K/3P2T3, Astris 15K/3P2T4, Astris 17K/3P2T4	40A
Astris 20K/3P2T4	50A
Astris 22K/3P2T4, Astris 25K/3P2T4	63A

Internal current detection equipment for inverter, the inverter detects the leakage of the power grid that is greater than the reduced value, and will be disconnected quickly from the power grid. If the external installation leakage protection device is installed, Its action electricity must be greater than equal to 300mA.

5.3 DC Connection



DANGER

-PV modules generate electric energy when exposed to sunlight and can create an electrical shock hazard. Therefore, when connecting the PV modules, shield them with opaque cloth and ensure that DC switches are OFF.

-To avoid electric shock, don't touch the charge part and connect the terminals carefully.

-Before connecting power cables, ensure the AC/DC switches are OFF.

-When the inverter is connected to the grid, don't plug in or plug out the PV strings.

-Don't perform any operation until the inverter is shut down.



WARNING

-PV modules connected in series in each PV string must be of the same specifications.

-The maximum open-circuit voltage of each PV string must be always lower than or equal to its permitted range.

-The maximum short circuit current of each PV string must be always lower than or equal to its permitted range.

-Ensure that the positive and negative terminals of each PV strings connected to the inverter correctly.

-The positive or negative terminals of PV strings can't be connected with short circuit.

-The total output power of all PV strings can't exceed the maximum input power of the inverter.



NOTICE

-The positive and negative terminals of PV modules can't connect to PE wire(GND) , otherwise, the inverter will be damaged.

-Ensure that the voltage of each PV string doesn't exceed 1100V under any circumstances.

-When the input voltage is 1000V to 1100V, the inverter will enter the standby state.

-When the voltage returns to the MPPT operating voltage, namely 160V-1000V, the inverter will return to the normal state.

5.3.1 Preparation

Different PV module input configuration module table (All PV strings are connected to the inverter in the corresponding groups number)

Before connecting the PV input to the inverter, ensure that the package meets the following electrical specifications.

Inverter module	Limit of each input open-circuit voltage	Maximum allowable input terminal current
All	1100V	20A

Open-circuit voltage altitude derating curve of the inverter as shown in the following figure

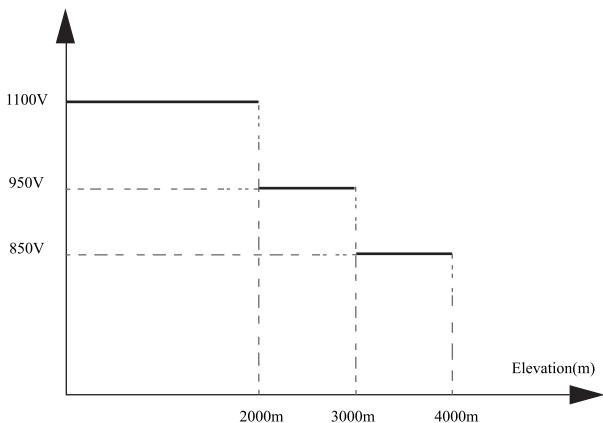

Open-circuit voltage altitude derating curve of the inverter

NOTE!

To ensure that the inverter reaches the enclosure of IP65, it can only use the connector provided by supply.

5.3.2 PV Connection

PV connection please refer to below.

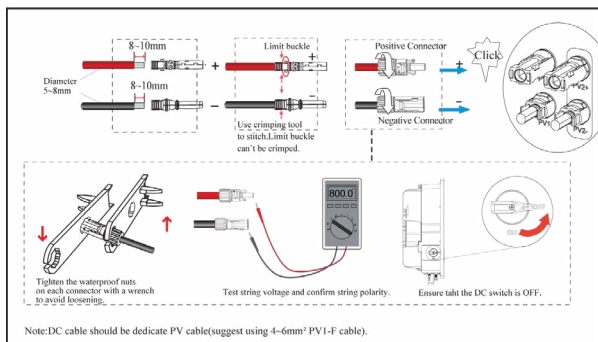

5.4 Communication Connection

5.4.1 Communication Mode Description

You can use the following communication modes to implement communication:

Bluetooth, WIFI, GPRS and RS485 which are described as follows.

- **Bluetooth Module**

You can turn on the Bluetooth function of the mobile phone, and set parameters and monitor data of the inverter through the mobile APP.

- **WIFI/GPRS/RS485 Modules**

Through DB9 communication interface is transferred to other communication modules to monitor the inverter. The module and functions are shown in Table 5.4

Module	Function description
WIFI	WIFI module implements communication with Cloud server through wire and wireless network to monitor PV inverter's data status. For more details, refer to WIFI Product Application Manual.
GPRS	GPRS module implements communication with Cloud server through wire and wireless network to monitor PV inverter's data status. For more details, refer to GPRS Product Application Manual
RS485	RS485 switching module monitors PV inverter's data status through collecting and uploading data to Cloud server

Table 5.4 Communications module description

5.4.2 WIFI/GPRS/LAN Module Connection (Optional)

WiFi/GPRS/LAN module connection please refer to below. For details about APP settings, see the WIFI/GPRS/LAN Module Installation Guide in the packing case.

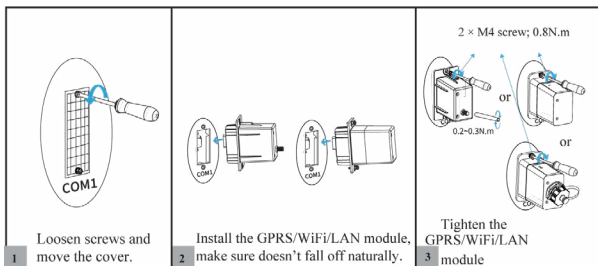

5.4.3 RS485 Connection

The multiple inverter network and RS485 communication are as follows:

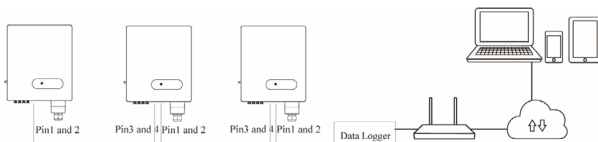

Install RS485 following this steps:

Step1 Loosen screws and remove the cover plate.

Step2 Wires making,threading and wiring.

Step3 Insert the 6-Pin terminal into the RS485 communication port.

Step4 Install the RS485 cover.

Step5 RS485 communication address setting.

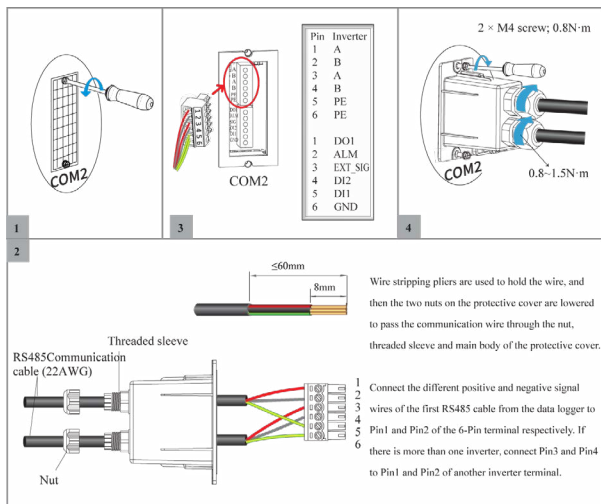

① Download the APP in either of the following ways

- Scan the QR code on the inverter to download the APP
- Download the APP from the APP store or Google Play.

Note: APP should access some permissions such as inverter's location. You need to allow all permissions to be granted in all pop-up windows when installing the APP or in your own phone setting.

② Power on the inverter.

③ Connect the inverter. Open the bluetooth on your phone, then open the APP.

Then follow the instructions below:

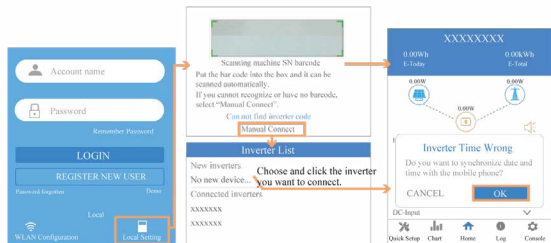

④ Go to Console > Communication Setting > RS485 Setting > Modbus Page, check the Modbus address (the default value is 1), and click to modify the address as required if necessary.

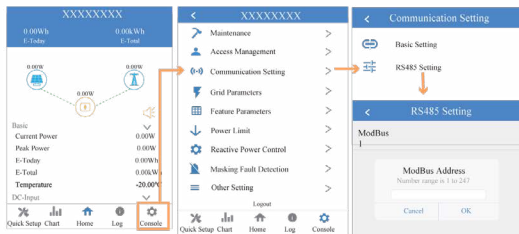

6 Startup/Shutdown Procedure

6.1 Check before startup/shutdown Procedure

Check following this steps after installation

No.	Items
1	The inverter is firmly installed
2	There is enough heat dissipation space, no external objects or parts left on the inverter
3	It is convenient for operation and maintenance.
4	The wiring of the system is correct and firm
5	Check whether the DC and AC connection are correct with a multimeter, and whether there is a short circuit, break, or wrong connection.
6	Check whether the waterproof nuts of each part are tightened
7	The vacant port has been sealed.
8	All safety labels and warning labels on the inverter are complete without occlusion or alteration

6.2 Startup Procedure

Startup procedure following the procedures :

Supply Main Switch

See if there's any on site
(The figure is only for reference)

①



AC Circuit Breaker

Switch to ON
(The figure is only for reference)

②

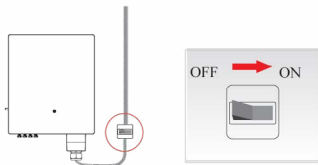

DC Switch
Switch to ON

③

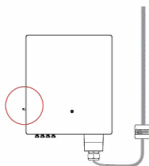

LED icon
Blue on (normal status)

④

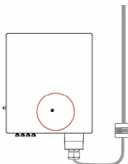

Finishing

⑤

Your system has started up

6.3 Shutdown Procedure

It may be necessary to shut down the inverter sometimes during the daily use. If necessary, please follow the procedures:

Supply Main Switch

See if there's any on site
(The figure is only for reference)

①

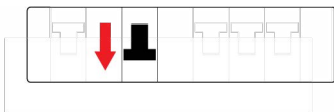

AC Circuit Breaker

Switch to OFF
(The figure is only for reference)

②

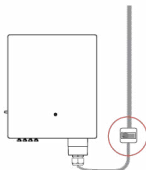

DC Switch
Switch to OFF

3

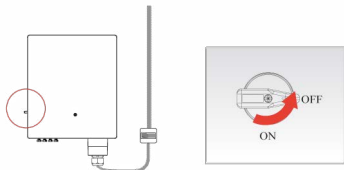

Wait at least 5 minutes
Let inverter fully
heat dissipation.

4



Finishing

5

Your system has shutdown



WARNING

After the inverter is powered off, the heat sink generates heat and there is excess electricity in the inverter. To avoid electric shocks and burns, powered off inverter for at least five minutes before performing operations.

7 User Interface

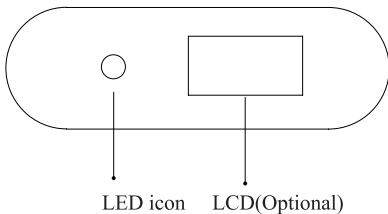

Inverter display panel is consist of LED icon and LCD(Optional).

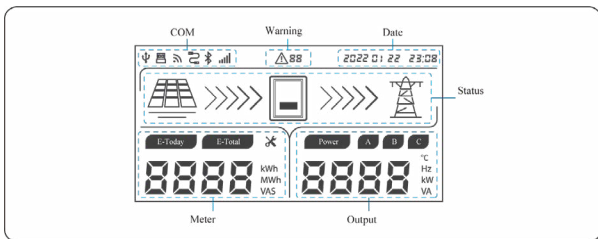

LED status	Descriptions
Blue led blink slowly 1s/time	Standby or startup state (not connected to the grid)
Blue on	Grid-tied status
Green on	Power limited status
Red led blink slowly 1s/time	Output side fault
Red led blink quickly 0.25s/time	lutput side fault
Red led on	System internal fault
Red/Green/Blue light alternately (1 color /0.25s)	Burning code(Master/Slave) Control power set up (lasts1second)



COM

When WIFI/GPRS/Bluetooth is transferring data, icon  will be ON, while no data transmission, the icon will be off after 10s. When RS485 is transferring data,  icon will be ON, while no data transmission, the icon will be off after 10s

Warning

When warning is triggered, icon will be illuminated: from left to right the first bit could be A/ B/ C, it stands for warning type, and the second bit is warning code, please refer to warning code in table for details.

Date

When external communications is normal and time zone is set correctly, the built-in clock of inverter will be synchronized with server's time. Without external communications, it is recommended to use the mobile app to set up time through connecting bluetooth to the inverter.





Status

Icon  stands for PV strings, when inverter is standby status, MPPT voltage of the PV string will be displayed in Meter zone.

Icon  stands for grid, when voltage and frequency of power grid is in normal range, the icon keeps on, or else, it blinks; when there is no voltage, the icon will be off.

Icon  stands for energy flow, when inverter is in normal status, the icon will be on, or else it will be off

Meter

<p>Normal status: today and total energy, MPPT voltage and current are showed in turn.</p>	 <p>The display shows four digital readouts: 'E-today' with '9988 kWh', 'E-total' with '1988 kWh', '988 V', and '10 A'.</p>
<p>Standby status: counter down value before inverter start up.</p>	 <p>The display shows a digital readout of '88' followed by a small 's'.</p>
<p>Any status: setting parameters via APP, the screen keep for 5 seconds.</p>	 <p>The display shows a digital readout of '1988' with a small asterisk '*' above it.</p>
<p>Normal status: output power, grid voltage and current are showed in turn.</p>	 <p>The display shows four digital readouts: '9988 W', '380 V', '10 A', and '50 Hz'.</p>

Warning table

Status	Details	Warning code
Red blink slowly	Grid over voltage	A0
	Grid under voltage	A1
	Grid absent	A2
	Grid over frequency	A3
	Grid under frequency	A4
	Grid abnormal	A6
	Grid high average voltage	A7
Red blink quickly	PV over voltage	B0
	PV Insulation resistance abnormal	B1
	Leakage current abnormal	B2
	PV Strings abnormal	B3
	PV under voltage	B4
Red on	Control power abnormal	C0
	Arc fault	C1
	High DC component of output current	C2
	Inverter relay abnormal	C3
	Inverter over temperature	C5
	Leakage current HCT abnormal	C6
	System type error	C7
	DC link voltage unbalanced	C9
	DC link over voltage	CA
	Internal communication error	CB
	Software incompatibility	CC
	EEPROM error	CD
	Consistent warning	CE
Inverter abnormal	CF	

Red on	Boost abnormal	CG
	Master Lost	CH
	Meter lost	CJ
Blue blink	Fan abnormal (standby)	C8
	Remote off	CN
Blue on	Fan abnormal (normal status)	C8

NOTE!

If you select a machine with a LCD screen, the warning code will be displayed on the LCD screen. Non-lcd screen models need to enter the app to view the corresponding warning code.

8 Troubleshooting and Maintenance



DANGER

Before maintaining and commissioning inverter and its peripheral distribution unit, switch off all the charged terminals of the inverter and wait at least 10 minutes after the inverter is powered off, otherwise there will be a high voltage shock.



WARNING

- Wrong maintenance will result in personnel injury or equipment damage!
- Before performing any maintenance operations, you must follow these steps:
First, disconnect the AC circuit breaker on the grid side, and then disconnect the DC switch.
Wait at least 10 minutes after the inverter is powered off, otherwise there will be a high voltage shock.
- Use testing equipment to make sure there no voltage or current



NOTICE

- Comply with ESD protection specifications and power distribution ESD bracelets.
- Avoid unnecessary contact with the circuit board.
- Touching printed circuit boards or other electrostatic sensitive components may cause damage during the process.

8.1 Troubleshooting

If the inverter is break down, the LED indicator will turn to red.

Alarm Information	Measures Recommended
A0-Grid over voltage	<ol style="list-style-type: none">1.If the alarm occurs accidentally, possibly the power grid is abnormal accidentally. No extra action is needed.2.If the alarm occurs repeatedly, contact the local power station. After receiving approval of the local power bureau, revise the electrical protection parameters setting on the inverter through APP.3.If the alarm persists for a long time,please confirm:<ol style="list-style-type: none">1) The AC circuit breaker does not jump frequently (the instantaneous high pressure);2) If the line of communication is followed by the user manual, the cable impedance will cause the power grid to rise;3) The three-phase machine measures whether the voltage between the zero line and the ground line exceeds 30V; More than the wiring of the grid; If there is no problem, Pls.contact the customer service center
A1-Grid under voltage	<ol style="list-style-type: none">1.If the alarm occurs accidentally, possibly the power grid is abnormal accidentally. No extra action is needed.2.If the alarm occurs repeatedly, contact the local power station. After receiving approval of the local power bureau, revise the electrical protection parameters setting on the inverter through APP.3.If the alarm persists for a long time,please confirm:<ol style="list-style-type: none">1) AC circuit breaker is disconnect ro not;2) Whether the AC circuit breaker is damaged (whether the voltage in the closed state is consistent with the voltage of the outlet);3) The AC terminals are in good contact.If the actual measuring voltage is within the specification range, please contact the customer service report repair

A2-Grid absent	<p>1.If the alarm occurs accidentally, possibly the power grid is abnormal accidentally. No extra action is needed.</p> <p>2. If the alarm occurs repeatedly, contact the local power station. After receiving approval of the local power bureau, revise the electrical protection parameters setting on the inverter through APP.</p> <p>3.If the alarm persists for a long time,please confirm:</p> <p>1) AC circuit breaker is disconnect or not;</p> <p>2) Whether the AC circuit breaker is damaged (whether the voltage in the closed state is consistent with the voltage of the outlet);</p> <p>3) The AC terminals are in good contact;</p> <p>4) Whether the power supply line failure.</p> <p>If exclude all possibility, please contact the customer service report repair.</p>
A3-Grid over frequency	<p>1.If the alarm occurs accidentally, possibly the power grid is abnormal accidentally. No extra action is needed.</p> <p>2.If the alarm occurs repeatedly, contact the local power station. After receiving approval of the local power bureau, revise the electrical protection parameters setting on the inverter through APP.</p>
A4-Grid under frequency	<p>1.If the alarm occurs accidentally, possibly the power grid is abnormal accidentally. No extra action is needed.</p> <p>2.If the alarm occurs repeatedly, contact the local power station. After receiving approval of the local power bureau, revise the electrical protection parameters setting on the inverter through APP.</p> <p>3.If the alarm persists for a long time, please contact the customer service center</p>
A6-Grid abnormal (Only for threephase inverter)	<p>1.If the alarm occurs accidentally, possibly the power grid is abnormal accidentally. No extra action is needed.</p> <p>2.If the alarm occurs repeatedly,please confirm:</p> <p>1) The three-phase voltage is measured, and confirm the three-phase voltage imbalance is more than 30%, Please improve the power supply condition of the power grid company.</p> <p>2) The three-phase AC circuit breaker is damaged or not (whether the voltage of the inlet line and the outlet of the outlet is consistent).</p> <p>3) The AC circuit breaker have zero line or not, and if the line is cut off, the short zero line confirmation problem is repeated. If not again, replace 3Pole switch or the zero line is short. If still, please contact customer service report repair</p>
B0-PV over voltage	<p>Check whether the maximum voltage of a single string of input PV modules exceeds the MPPT voltage range. If the maximum voltage is higher than the standard voltage, modify the number of PV module connection strings</p>
B1-PV insulation abnormal	<p>1.If the alarm occurs accidentally, the inverter can generate power. Check the installation environment is wet or not of the component and wire rope,and improve the installation environment.</p> <p>2..If the alarm occurs repeatedly, the inverter can generate electricity occasionally. Check whether the positive and negative polarity of the pv component is short circuit, and check the component is damaged or the connection line is broken.</p> <p>3.If the alarm continues, equipment cannot generate power, please contact customer service report repair.</p>

B2-Leakage current abnormal	<ol style="list-style-type: none"> 1.If the alarm occurs accidentally, the inverter can generate power, which may cause the power grid to cause the inverter to automatically recover. No extra action is needed. 2.If the alarm occurs frequently, and is accompanied by an insulation impedance alarm. Check the abnormal alarm of the insulation. 3. If the alarm continues, the equipment cannot generate electricity, please contact the customer service report repair
B4-PV under voltage	<ol style="list-style-type: none"> 1.If occurs when the light is weak(such as the early morning or evening, and the extreme weather of rain and dust storms), the component voltage is lower than normal, No extra action is needed. 2.If there is a weak condition of light, please check the group to have a short circuit and open circuit or not
B5-PV irradiation weak	Normal phenomena under light weak conditions. No extra action is needed.
B7-PV string reverse	Check and modify the positive and negative polarity of the input of the circuit string
C0-Internal power supply abnormal	<ol style="list-style-type: none"> 1. If the alarm occurs occasionally, the inverter can be automatically recovered and no action is required. 2. If the alarm occurs repeatedly, the inverter cannot work properly. Please contact the customer service center.
C2-Inverter over dcbias current	<ol style="list-style-type: none"> 1. If the alarm occurs occasionally, the inverter can be automatically recovered and no action is required. 2. If the alarm occurs repeatedly, the inverter cannot work properly. Pls.contact the customer service center
C3-Inverter relay abnormal	<ol style="list-style-type: none"> 1. If the alarm occurs occasionally, the inverter can be automatically recovered and no action is required. 2.If the alarm occurs repeatedly, the single-phase inverter, please check whether the live line and zero line of the contact connection is reversed; the three-phase inverter check the live line to zero line and the voltage of the live line to the ground. If the grid side is normal, please contact the customer service report repair.
C5-Inverter over temperature	<ol style="list-style-type: none"> 1. If the alarm occurs occasionally, the inverter can be automatically restored, no action required. 2. If the alarm occurs repeatedly, pls. check the installation site for direct sunlight, good ventilation, and high ambient temperature (Such as installed on the parapet). If the ambient temperature is lower than 45° C and the heat dissipation is good, contact the customer service center.
C6-GFCI abnormal	<ol style="list-style-type: none"> 1. If the alarm occurs occasionally, it could have been an occasional exception to the external wiring, the inverter can be automatically recovered, no action required. 2. If it occurs repeatedly or cannot be recovered for a long time, pls.contact customer service to report repair.
C7-System type error	If the alarm occurs, the inverter can not work, pls. restart the inverter If the alarm continues, pls.contact customer service to report repair.t

C8-Fan abnormal	<ol style="list-style-type: none"> 1. If the alarm occurs occasionally, pls. restart the inverter. 2. If it occurs repeatedly or cannot be recovered for a long time, check whether the external fan is blocked by foreign objects. Otherwise, contact customer service.
C9-Unbalance Dclink voltage	<ol style="list-style-type: none"> 1. If the alarm occurs occasionally, the inverter can be automatically recovered and no action is required. 2. If the alarm occurs repeatedly, the inverter cannot work properly. Please contact the customer service center.
CA-Dc-link over voltage	
CB-Internal communication error	
CC-Software incompatibility	
CD-Internal storage error	
CE-Data inconsistency	
CF-Inverter abnormal	
CG-Boost abnormal	
Remote monitoring data is not updated	<p>If this phenomenon occurs occasionally, it will not be used for communication signals.</p> <p>If long time data is not updated, pls.contact customer service report repair.</p>
Remote monitoring	<ol style="list-style-type: none"> 1.The inverter is normal, the communication is short, and the data is in the data. This state does not need to be processed. 2.The inverter is normal and is in a mater, please check whether the inverter is normal and the ac switch is closed
No display of the inverter indicator	<p>Confirm whether the input voltage of the inverter is normal, if the input voltage is less than 120V. Check the component, and if the voltage is normal, contacting the customer service report repair.</p>
Low power generation	<ol style="list-style-type: none"> 1.Check the electricity generation on the meter and confirm whether the data is consistent with the monitoring data; 2.Cherk components, avoid components because of the loss of the power generation caused by occlusion, dust, breakage, etc. 3.Check the monitoring data to confirm whether the inverter is exposed to the network because the alarm is frequently removed, And if there is a warning, the alarm shall be handled accordingly

Information on how the inverter can comply with the earth fault alarm requirements of AS/NZS 5033.

8.2 Maintenance

Routine Maintenance of inverter

Check Item	Check Content	Maintain content	Maintenance Interval
Inverter output status	Statistically maintain the status of electrical yield, and remotely monitor its abnormal status.	NA	Weekly
Inverter appearance	Check periodically and ensure that the heat sink is free from dust and blockage.	Clean periodically the heat sink	Yearly
Inverter running status	a.Check that the inverter is not damaged or deformed. b.Check for normal sound emitted during inverter operation. c.Check and ensure that all inverter communications is running well.	If there is any abnormal phenomenon ,replace the relevant parts.	Mouthly
Inverter Electrical Connections	a.Check and ensure that AC, DC, and communication cables are securely connected; b.Check and ensure that PGND cables are securely connected; c.Check and ensure that cables are intact and free from aging;	If there is any abnormal phenomenon, replace the cable or re-connect it.	Semiannually

Fan Maintenance

The inverter external fan abnormal will cause the inverter can't be cooled effectively, affect the efficiency of the inverter or cause the reduction to run. Keep the fan clean and replace the damaged fan in time.

Step1 Shutdown the inverter.

Step2 Refer to electrical connection installation and disconnect the inverter in the opposite steps.

Step3 Refer to mechanical installation and remove the inverter in the opposite steps.

Step4 Screw down two security screws anticlockwise which on the inverter fan bracket.



Disposal of Old Electrical & Electronic Equipment

(Applicable in the European Union and other European countries with separate collection systems)

This symbol on the product or on its packaging indicates that this product shall not be treated as household waste.

Instead it shall be handed over to the applicable collection point for the recycling of electrical and electronic equipment.

By ensuring this product is disposed of correctly, you will help prevent potential negative consequences for the environment and human health, which could otherwise be caused by inappropriate waste handling of this product.

The recycling of materials will help to conserve natural resources.

Introducere	42
Simboluri de siguranta	43
Masuri de siguranta	43
1.1 Simboluri utilizate	44
1.2 Precautii de siguranta	44
Prezentare produs	46
2.1 Notiuni generale	46
2.2 Descrierea modelului de invertor	46
2.3 Infatisare produs	47
Inspectare continut si depozitare	49
3.1 Inspectie	49
3.2 Depozitarea invertorului	50
3.3 Identificarea modelului de invertor	50
Instalare	51
4.1 Selectarea locatiei de instalare	51
4.2 Instalare	55
Conexiunile electrice	57
5.1 Impamantarea	57
5.2 Conexiunea AC	59
5.3 DC Connection	61
5.4 Conectarea cablurilor de comunicatie	64
Procedura de pornire / oprire	68
6.1 Inainte de procedura urmati acesti pasi:	68
6.2 Procedura de pornire	68
6.3 Procedura de inchidere	69
Interfata cu utilizatorul	70
Depanare si mentenanta	74

8.1 Depanare	75
8.2 Mentenanta	79

Va rugam sa parcurgeti manualul inainte de a instala si opera inverterul.

Se adreseaza urmatoarelor modele :

SIN320050002ATCU0B - Astris 5K /3P2T2

SIN320060002ATCU0B - Astris 6K /3P2T2

SIN320080002ATCU0B - Astris 8K /3P2T2

SIN320100002ATCU0B - Astris 10K /3P2T2

SIN320100003ATCU0B - Astris 10K /3P2T3

SIN320120003ATCU0B - Astris 12K /3P2T3

SIN320120004ATCU0B - Astris 12K /3P2T4

SIN320150003ATCU0B - Astris 15K /3P2T3

SIN320150004ATCU0B - Astris 15K /3P2T4

SIN320170004ATCU0B - Astris 17K /3P2T4

SIN320200004ATCU0B - Astris 20K /3P2T4

SIN320220004ATCU0B - Astris 22K /3P2T4

SIN320250004ATCU0B - Astris 25K /3P2T4





Acest manual prezinta inverterul din punct de vedere al montarii, instalarii si conectarii electrice, functionarii, punerii in functiune, mentenantei si a depanarii. Va rugam sa parcurgeti manualul inainte de a instala si opera inverterul si pastrati-l pentru viitoare referinte.

Pentru personal autorizat

Acest manual de utilizare este dedicat personalului autorizat in instalatii invertoare solare si pentru electricienii calificati.

Simboluri de siguranta

Simbolurile utilizate in acest manual evidentiaza riscurile potentiale si informatiile care asigura siguranta operatorului, si sunt prezentate dupa cum urmeaza:

Symbol	Description
 PERICOL	Indica situatii periculoase iminente care incorect executate pot rezulta in raniri grave, chiar moartea
 AVERTISMENT	Indica situatii potential periculoase care incorect executate pot rezulta in raniri grave, chiar moartea
 ATENTIONARE	Indica situatii potential periculoase care incorect executate pot rezulta in raniri usoare si moderate.
 NOTIFICARE	Indica situatii potential periculoase care incorect executate pot rezulta in daune asupra echipamentului sau proprietatii.
 BINE DE STIUT	Atrage atentia asupra unor informatii importante, bune practici sau sfaturi: este o suplimentare a instructiunilor de siguranta si pentru o mai buna operare a echipamentului









1 Masuri de siguranta

Va rugam sa parcurgeti manualul inainte de a instala si opera invertorul si pastrati-l pentru viitoare referinte.

Invertorul este testat si este conform cu cerintele de siguranta. La instalare, operare si mentenanta, reglementarile locale trebuie urmate cu strictete. Operarea incorecta poate afecta echipamentul si rani mortal persoanele care intra in contact cu el.

Pentru a preveni aceste consecinte va rugam sa respectati normele de siguranta.

1.1 Simboluri utilizate

Simbol	Descriere
	Pericol de electrocutare! Doar personalul autorizat are acces la aceasta unitate!
	Tensiuni inalte. Pericol! Tensiunea reziduala se mentine inca 5 minute dupa oprire. Nu executati lucrari decat dupa aceste 5 minute.
	Suprafata foarte fierbinte
	Pericol de foc
	Perioada de utilizare in siguranta
	Indica o referinta catre documentatia de operare
	Produsul nu trebuie aruncat impreuna cu gunoiul menajer Eliminarea sa trebuie sa se faca in conformitate cu reglementarile locale ce vizeaza Deseurile Electrice si Electronice.
	Terminal de impamantare

1.2 Precautiile de siguranta

- Invertorul trebuie instalat, conectat, operat si verificat doar de tehnicieni calificati, in conformitate cu standardele si reglementarile electrice locale, regulile de conectare si cerintele autoritatilor.
- Pentru a evita pericolul de electrocutare, intrarea DC si iesirea AC trebuie inchise inainte cu 10 minute de orice fel de interventie tehnica, cum ar fi mentenanta. Intotdeauna luati masurile adecvate pentru a evita socurile electrice.
- Temperatura anumitor parti din invertor poate ajunge la peste

60°C in timpul functionarii. Pentru a evita arsuri grave nu atingeti invertorul.

- Asigurati-va ca este restrictionat accesul copiilor la inverter.
- Nu deschideti carcasa invertorului. In afara interventiilor la terminale nu este permisa schimbarea componentelor interne fara autorizarea lucrarii. Aceste schimbari pot produce pagube, raniri si anularea garantiei.
- Incarcarea electrostatica poate dauna componentelor electronice. Luati masurile necesare pentru a evita aceste efecte. In caz contrar, invertorul se poate defecta si garantia se va anula.
- Asigurati-va ca tensiunea de la panourile fotovoltaice este mai mica decat maximul de tensiune sustinut de inverter, in caz contrar invertorul se va defecta, iar garantia se va anula
- Expuse la soare, panourile solare genereaza energie electrica continua de tensiuni ridicate. Va rugam respectati instructiunile pentru a evita punerea in pericol a vietii operatorului sau tertilor.
- Panourile solare care vor fi conectate trebuie sa aibe ratingul IEC61730, clasa A.
- Daca echipamentul va fi folosit in alt mod decat cel mentionat de producator, protectiile echipamentului nu vor functiona.
- Izolati complet invertorul inainte de a executa mentenanta. Izolarea consta in: inchiderea intrerupatorului si deconectarea terminalului de la panouri, deconectati terminalul de la baterii si deconectati terminalul AC.
- Este interzisa conectarea sau deconectarea terminalelor AC and DC atunci cand invertorul functioneaza
- Un sir de panouri solare nu ar trebui conectate la doua sau mai multe invertoare.

2 Prezentare produs

2.1 Notiuni generale

Invertorul hibrid

Invertoarele On-Grid trifazice convertesc tensiunea continua generata de panourile solare in tensiune alternativa, punand-o atat la dispozitia retelei electrice cat si la cea a echipamentelor conectate la acestea.

Aceste invertoare sunt o parte componenta importanta a sistemului fotovoltaic si se pot utiliza atat in medii rezidentiale cat si in cele comerciale.

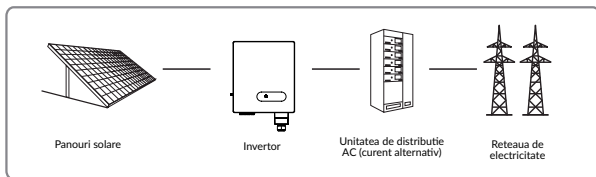

Acest invertor este potrivit pentru instalatii on-grid de tip TN-S, TN-C, TN-C-S si TT. Acestea sunt ilustrate in schemele de mai jos:

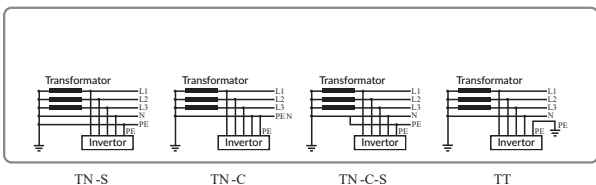

2.2 Descrierea modelului de invertor

Semnificatia simbolurilor de pe modelul de invertor (utilizand ca exemplu modelul Astris 10K/3P2T2).

10K/3P2T2



2.3 Infatisare produs

Urmatoarele schite sunt folosite doar ca exemplu:

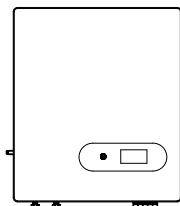
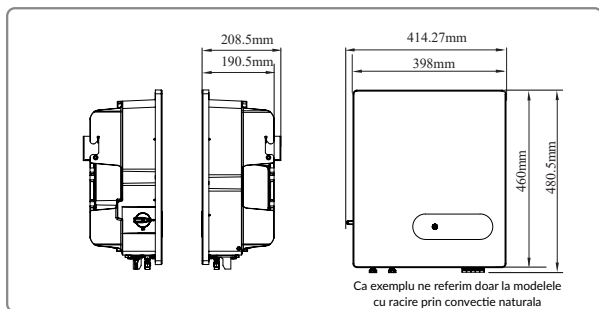

Serie cu racire pasiva

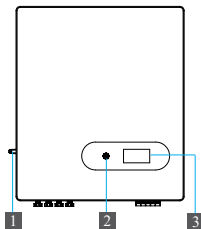

Serie cu racire cu ventilator

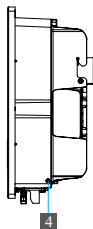

Numar	Descriere
1	Intrerupator DC
2	Indicatori LED
3	Ecran LCD (optional)
4	Terminal de impamantare

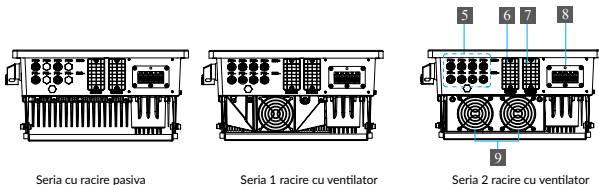

Numar	Descriere
5	Terminal conectori panouri PV
6	Port de comunicare RS485
7	Port de comunicare (optional) WiFi/GPRS/LAN
8	Port de iesire AC
9	Ventilator extern (doar pentru modele cu racire prin ventilator)

3 Inspectare continut si depozitare

3.1 Inspectie

La primirea invertorului, verificati ca ambalajul sa fie intact.
Dupa inlaturarea ambalajului, verificati ca toate componentele sa fie in
intacte si complete, in concordanta cu lista de livrabile din comanda.

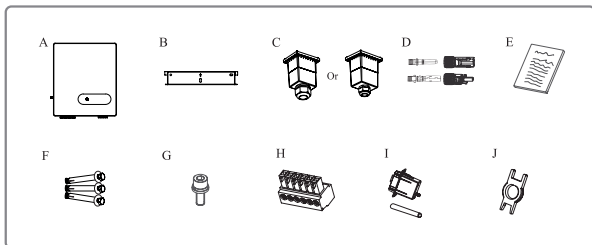

Notatie litera	Description livrabil	Cantitate
A	Invertor	1
B	Brachetii de montare C 1	1
C	Capac de izolare AC	1
D	Conectori terminale PV	2 or 4
E	Manual de utilizare	1
F	Suruburi de ancorare	3
G	Suruburi de securizare	2
H	Terminal 6 pini	1
I	Modul WiFi/GPRS (optional)	1 (Optional)
j	Unealta de indepartare conector PV (optional)	1 (Optional)



NOTIFICARE

Contactati unitatea de unde ati achizitionat produsul daca intampinati probleme la aceasta operatiune.

3.2 Depozitarea invertorului

Daca invertorul nu este instalat si utilizat imediat dupa livrare, pastrati invertorul in urmatoarele conditii:

- Nu desfaceti ambalajul, iar in cazul in care este necesar, puneti plicuri cu agent anti-umiditate in cutia invertorului.
- Temperatura de depozitare este intre -25°C si +60°C; umiditate relativa intre 0-100%..
- Nu depozitati invertorul inclinat excesiv frontal, lateral sau invers. Pastrati pozitia indicata pe simbolul cutiei.
- Asigurati-va ca invertorul este testat de personal calificat inainte de instalare in cazul in care a fost depozitat o perioada lunga de timp.

3.3 Identificarea modelului de invertor

Abtibilul de pe invertor contine informatiile urmatoare (informatiile sunt folosite ca exemplu).

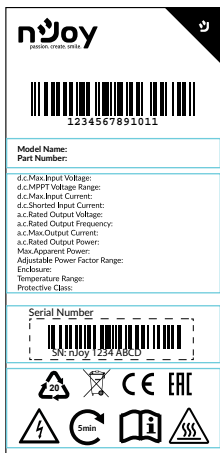

Numar	Descriere
1	Nume produs si serie model
2	Parametrii tehnici
3	Cod de bare Serial Number
4	Simboluri de siguranta

4 Instalare

After checking the outer packing, move the PV inverter to the designated installation position horizontally.

AVERTISMENT

1. Va rugam asezati invertorul pe bucati de polistiren expandat sau alte materiale moi pentru a nu pune presiune pe porturile de conectare din partea inferioara si a le deteriora.
2. Invertorul are o greutate mare, mariti atentia cand manipulati invertorul pentru a preveni eventualele accidente si raniri ale tehnicienilor implicati.

PERICOL

Asigurati-va ca nu exista conexiuni electronice la porturile invertorului inainte de instalarea sa.

4.1 Selectarea locatiei de instalare

4.1.1 Cerinte pentru mediu de instalare

- a. Invertorul are certificarea IP65 si poate fi montat in interior sau exterior
- b. Nu instalati invertorul intr-un loc usor accesibil de personal neautorizat care poate veni in contact cu oricare parte a carcasei sau radiator si pot suferi arsuri sau electrocutari.
- c. Temperatura ambientala trebuie mentinuta sub 50°C pentru o functionare corecta si o durata de viata mai mare.
- d. Invertorul trebuie instalat intr-un spatiu foarte bine ventilat pentru a asigura disiparea eficienta a caldurii.
- e. Invertorul nu trebuie expus direct la razele soarelui, ploaie, ninsoare pentru a-i extinde perioada de viata. Este recomandat sa fie instalat in interior. Daca nu este posibila instalarea in interior este recomandata achizitionarea unei copertine sau acoperis.
- f. Adapostul unde se va efectua instalarea invertorului trebuie sa fie rezistent la foc. Nu instalati invertorul aproape de materiale inflamabile
- g. Nu instalati invertorul pe pereti falsi, placi de gips-carton sau pereti slab izolati fonic pentru a evita zgomotele puternice produse in timpul

functionarii.

h. Inaltimea la care se instaleaza invertorul trebuie sa fie rezonabila pentru a se executa usor lucrari de mentenanta sau observa display-ul.

i. Etichetele cu avertismentele de siguranta trebuie sa fie usor de citit si dupa instalare.

j. Evitati instalarea in bataia directa a soarelui, ploii sau zapezii.

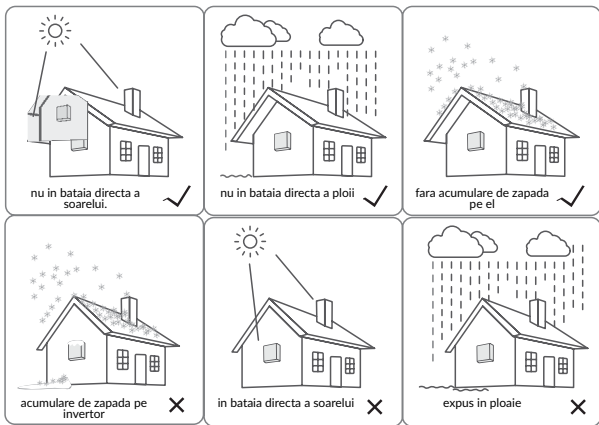

4.1.2 Mounting Requirements

Invertorul se va monta vertical, paralel cu peretele sau inclinat spre spate la un unghi de maxim 15° pentru a facilita disiparea caldurii invertorului.



NOTIFICARE

instalare defectuasa a invertorului va duce la deteriorarea sa si acesta nu va functiona in parametrii prevazuti.

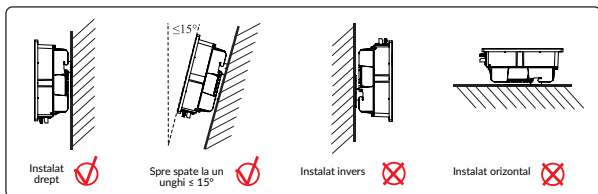

4.1.3 Cerinte pentru spatiul de instalare

Un spatiu de ventilare adecvat trebuie avut in vedere la momentul instalarii. Montarea invertorului trebuie sa se faca in pozitie verticala si asigurati-va ca niciun obiect nu obstructioneaza radiatorul, si implici racirea corespunzatoare.

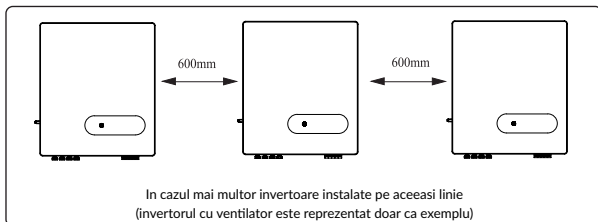
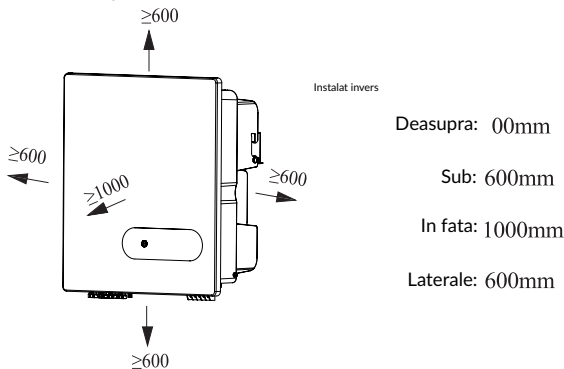

4.2 Instalare

Pasul 1. Instalatii bracketii de suport

PERICOL

1. Peretele pe care se va efectua instalarea trebuie sa fie rezistent la foc, fara materiale inflamabile pentru a nu exista risc de incendiu.
2. Inainte de a efectua gauri pentru montare, va rugam sa va asigurati ca nu atingeti tevi de apa sau cabluri electrice.

1) Masurati pe perete cele 3 orificii corect cu ajutorul unui indicator de nivel si marcati-le utilizand un marker. Gauriti cu un ciocan rotopercurtor cele 3 orificii, 10mm in diametru si 60mm adancime. Utilizati ca ilustratie figurile 1 si 2.

2) Strangeti partial un surub pe diblu si introduceti-l utilizand un ciocan de cauciuc. Utilizati ca ilustratie figura 3.

Nota: Nu scoateti piulita surubului de fixare.

3) Dupa ce suruburile sunt fixe in perete, desurubati piulita, saiba cu arc, si garnitura, observati figura 3.

4) Fixati bracketii pe perete, suruburile de pe bracketi trebuie sa fie aliniata cu diblurile instalate deja pe perete, apoi strangeti garnitura si suruburile. Utilizati ca ilustratie figura 4.

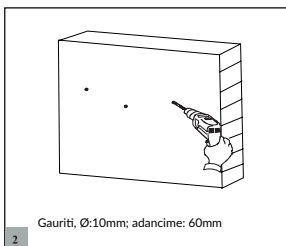
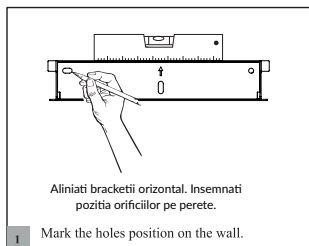

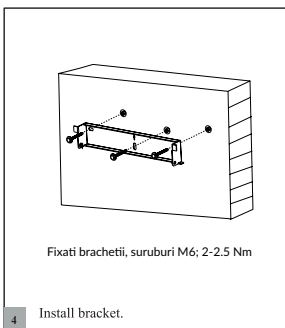
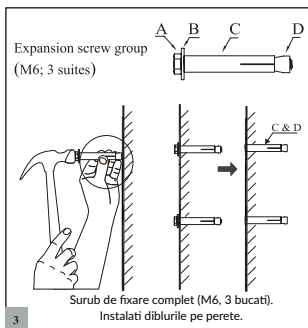

Pasul 2. Instalati invertorul

Instalati invertorul pe bracheti si strangeti suruburile de pe ambele parti cum este ilustrat in pasul 5 si 6.



ATENTIONARE

Pentru a preveni deteriorarea invertorului, nu slabiti stabilitatea lui inainte de a va asigura ca este perfect fixat in brachetii de pe perete.

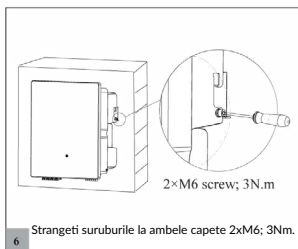
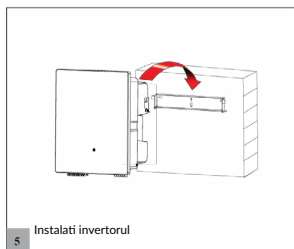

5 Conexiunile electrice

Conectarea sistemului

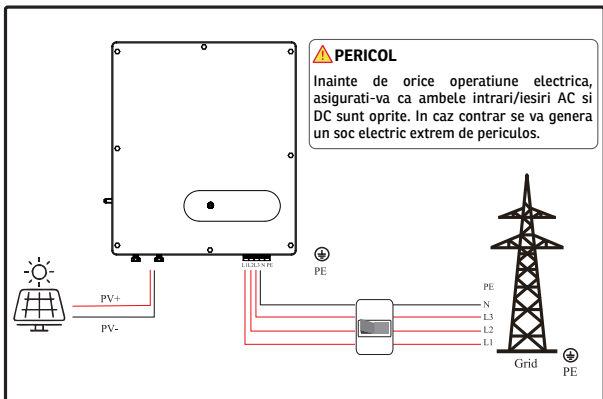

5.1 Impamantarea

In conformitate cu cerintele EN50178, in partea dreapta a echipamentului se afla conexiunea la impamantare. Asigurati-va ca va fi cablu de impamantare conectat la acest port in timpul instalarii invertorului. Conexiunea la impamantare se va executa in functie de conditiile de la locul in care se realizeaza instalarea.

Pasul.1 Indepartati stratul izolator de pe capatul cablului de impamantare utilizand un cleste de dezimbare, pe o portiune putin mai lunga cu 2-3 mm decat clama terminalului OT, cum este prezentat in schema de mai jos.

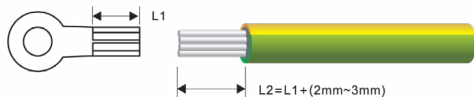

Pasul 2 Introduceți firele expuse ale cablului în clama terminalului OT și strângeți-le utilizând clești hidraulici, cum este prezentat în schema de mai jos.

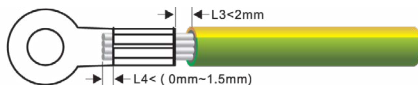

Pasul 3. Îndepărtați șuruburile de la punctele de împământare, cum este prezentat în schema de mai jos.

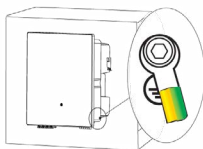

Obiect	Remarca
Șurub	M6X12; 3Nm
Terminal OT	OT6-6(5K-15K); OT16-6(17K-25K)
Fire verzi-galbene	S(Yellow green lines) \geq S(PE line of DC cable) S este suprafața secțiunii

Asigurați-vă că rezistența la împământare este mai mică de 10 Ohmi

AVERTISMENT

În conformitate cu reglementările curente, protecția secundară la împământare nu înlocuiește conexiunea terminalului PE la cablul AC. Asigurați-vă că ambele sunt împământate corect. În caz contrar, tensiunile mari pot cauza moartea.

ATENȚIONARE

Dacă polul pozitiv sau negativ al sirului de panouri PV este necesar să fie împământat, atunci ieșirea invertorului (către rețeaua AC/ grid) trebuie izolată cu transformator în concordanță cu standardul IEC63109-1,-2.

5.2 Conexiunea AC

5.2.1 Conectarea cablului AC

1. Masurati tensiunea si frecventa in acest punct pentru a va asigura ca ele corespund cu specificatiile inverterului.
2. Firul PE (GND) se va izola foarte bine pentru a asigura o impedanta mai mica de 10Ω intre neutru si impamantare.
3. Decuplati circuitul de izolare sau siguranta de la inverter si punctul de conectare la on-grid/retea.
4. Utilizati cablu de cupru.
5. Urmariti acesti pasi.

Nume		Model	5K-15K	17K-20K	22K-25K
A	Diametru exterior cablu (mm)		11-18	24-32	24-32
B	Dimensiune sectiune (mm ²)	Distanta	4-6	6-16	10-16
		Recomandat	6	10	16

Nota: Folositi cabluri de exterior cu multiple fire de cupru.

1 Selectati cabluri AC si terminal OT corecte (cu 5 fire)

Desurubati piulita capacului si treceti firele cablului AC (cele 5 fire) prin piulita si capac. Apoi sertizati terminalul OT si utilizati tuburi termocontractibile sau banda izolatoare pentru protectie.

2 Sortarea si pregatirea firelor

3 Inserati cablul AC in terminalele AC corespondente.

	Screw	Torque	D
5K-15K	M4	1.5N.m	10mm
17K-25K	M5	3N.m	12.5mm

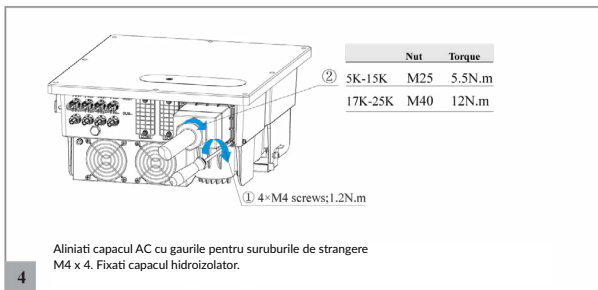

5.2.2 Intrerupator AC si protectia impotriva scurgerii de curent

Pentru a deconecta invertorul de la retea in siguranta, un intrerupator AC trebuie instalat pentru fiecare inverter.



AVERTISMENT

- Nu se vor conecta mai multe invertoare la acelasi intrerupator.
- Nu se vor conecta consumatori pe circuit intre inverter si intrerupatorul AC.

Inverter	Valoare recomandata
Astris 5K/3P2T2, Astris 6K/3P2T2, Astris 8K/3P2T2	20A
Astris 10K/3P2T2, Astris 10K/3P2T3, Astris 12K/3P2T3	32A
Astris 15K/3P2T3, Astris 15K/3P2T4, Astris 17K/3P2T4	40A
Astris 20K/3P2T4	50A
Astris 22K/3P2T4, Astris 25K/3P2T4	63A

Invertorul are o protectie proprie pentru scurgerea de curent din retea, iar in cazul in care aceasta se declanseaza invertorul se va deconecta de la retea publica. In acest sens, daca se va instala o protectie aditionala, externa, pentru scurgere de curent, este necesar ca aceasta sa se declanseze la o valoarea mai mare sau egala cu 300mA.

5.3 DC Connection



PERICOL

- Panourile fotovoltaice genereaza electricitate cand sunt expuse la razele solare astfel ca exista riscul de soc electric.
- La instalarea lor, recomandam acoperirea lor cu un material opac iar intreruptoarele DC sunt oprite.
- Pentru a evita electrocutarea nu atingeti nicio parte a invertorului.
- Inainte de a conecta cabluri de alimentare, asigurati-va ca sunt oprite intreruptoarele AC si DC.
- Atunci cand invertorul este legat la retea electrica, nu este permisa interventia sau mentenanta la cablurile de intrare DC, cum ar fi deconectarea unui sir de panouri.
- Abia dupa ce invertorul este complet oprit se poate realiza interventia.



AVERTISMENT

- Panourile conectate in serie trebuie sa fie cu specificatii identice.
- Asigurati-va ca tensiunea pe fiecare circuit deschis al fiecarui sir de panouri PV este mai mica sau egala cu intervalul admis.
- Curentul maxim in circuit deschis al fiecarui sir de panouri PV trebuie sa fie mai mic sau egal cu intervalul acceptat.
- Asigurati-va ca terminalele +/- ale panourilor sunt conectate la invertor corect si ca nu exista nici un scurt-circuit..
- Totalul puterii generate de panouri nu poate sa depaseasca valoarea maxima admisa de invertor.

Notificare

- Terminalele +/- ale panourilor nu se conecteaza la firul PE (GND), in caz contrar invertorul va fi avariat.
- Asigurati-va ca tensiunea totala a fiecarui sir nu depaseste 1100V sub nicio circumstanta.
- Cand tensiunea de intrare este intre 1000V si 1100V, invertorul va intra in stand-by. Cand tensiunea se intoarce in limite normale de operare, si anume 160V-1000V, invertorul se va intoarce in starea de functionare normala.

5.3.1 Pregatirea

Diferite tipuri de panouri PV implica diferite configuratii in functie de modulele invertorului (toate panourile se conecteaza la invertor in grupuri).

Inainte de a conecta intrarea panourilor la invertor, asigurati-va ca respecta urmatoarele specificatii electrice:

Modul invertor	Limita de tensiune in circuit deschis	Limita maxima de curent de intrare pe terminal 20A
Toate	1100V	20A

Curba de descreștere a tensiunii în circuit deschis corelată cu creșterea altitudinii este prezentată în schema următoare:

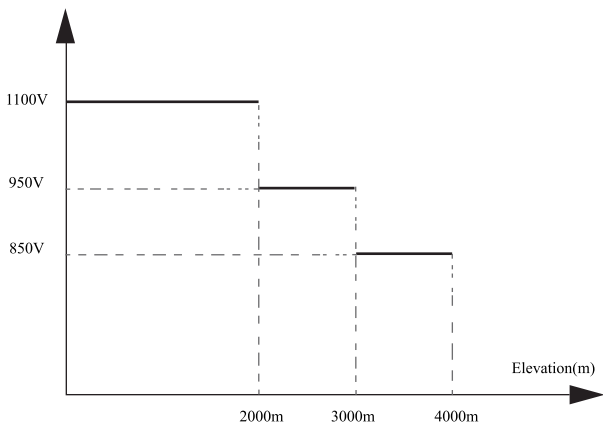

Open-circuit voltage altitude derating curve of the inverter

NOTIFICARE!

Pentru a va asigura ca inverterul este conform cu standardul IP65, se poate utiliza doar conectorul livrat de producator.

5.3.2 Conexiunea PV

Pentru conexiunea PV utilizati schema de mai jos.

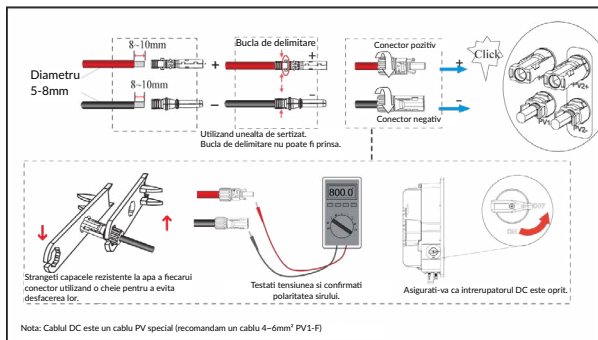

5.4 Conectarea cablurilor de comunicatie

5.4.1 Modalitati de comunicatie

Comunicarea cu inverterul se poate realiza in urmatoarele moduri: Bluetooth, Wi-fi, GPRS, RS485.

- Modul bluetooth

Pentru a folosi aceasta modalitate porniti functia Bluetooth pe telefon, setati parametrii de functionare si monitorizati inverterul prin aplicatia mobila. Pentru detalii va rugam sa consultati manual de utilizare al aplicatiei.

- Modul WI-FI & GPRS & RS485

Interfata de comunicare DB9 este folosita pentru a realiza conexiunea urmatoarelor moduri :

Modul	Descriere functionalitate
WIFI	Acest mod se implementeaza prin Cloud si modul wireless al invertorului pentru a monitoriza statusul. Pentru mai multe detalii va rugam sa consultati manualul de utilizare al aplicatiei WI-FI.
GPRS	Acest mod se implementeaza prin Cloud si modul wireless al invertorului pentru a monitoriza statusul. Pentru mai multe detalii va rugam sa consultati manualul de utilizare al aplicatiei GPRS..
RS485	Comutatorul RS485 monitorizeaza statusul invertorului si il incarca intr-un server Cloud. Pentru mai multe detalii va rugam sa consultati manualul de utilizare al comutatorului RS485.

Table 5.4 Communications module description

5.4.2 Conectarea modului WIFI/GPRS/LAN (optional)

Pentru mai multe detalii legate de conectarea modului WIFI/GPRS/LAN utilizati ghidul de utilizare din pachet.

Pentru conectare urmariti schema de mai jos.

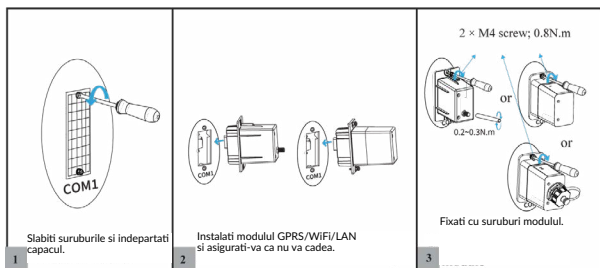

5.4.3 Conectarea RS485

Conexiunea dintre invertoare multiple si comunicarea RS485 se desfasoara astfel:

Instalati RS485 urmarind pasii:

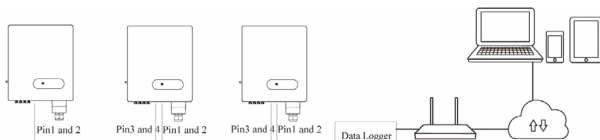

Instalati RS485 urmarind pasii:

1. Slabiti suruburile si indepartati capacul.
2. Conectati firele.
3. Inserati terminalul cu 6-pini in portul de comunicare RS485.
4. Atasati capacul RS485.
5. Setati adresa de comunicare RS485.

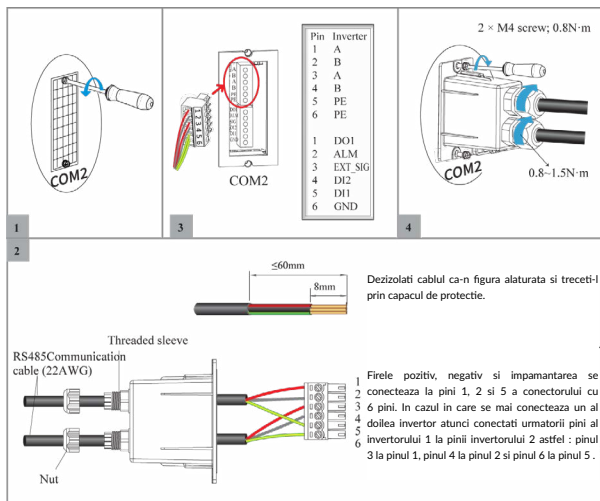

1. Descarcati aplicatia prin urmatoarele proceduri:

Scanati codul QR de pe inverter.

Descarcati aplicatia din Appstore sau Google Play.

Nota: Aplicatia va avea nevoie de permisiune pentru a accesa locatia inverterului.

Puteti face acest lucru la instalare sau mai tarziu din setarile telefonului.

2. Porniti inverterul.

3. Conectati-va la inverter prin Bluetooth cu ajutorul telefonului, apoi

deschideti aplicatia si urmariti instructiunile urmatoare:

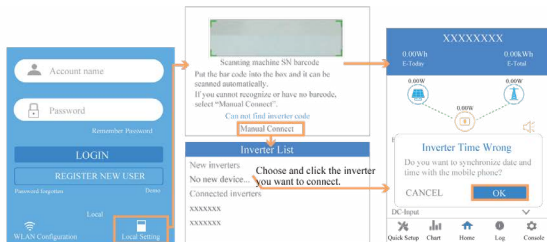

4. Mergeti la Console>Communication Setting > RS485 Setting > Modbus Page, verificati adresa Modbus (valoarea implicita este 1) si modificati adresa sa fie conforma (daca e necesar).

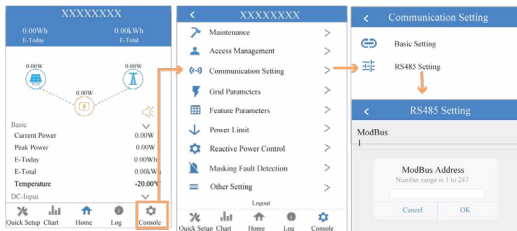

6 Procedura de pornire / oprire

6.1 Inainte de procedura urmati acesti pasi:

Inainte de procedura urmati acesti pasi:

Numar	Obiect
1	Invertorul este instalat corect
2	Este suficient spatiu pentru disiparea caldurii; niciun obiect nu este lasat pe sau in interiorul invertorului.
3	Este instalat intr-un mod care asigura functionarea si mentenanta facila
4	Cablarea este corecta si rezistenta
5	Verificati corectitudinea conexiunilor DC si AC cu un multimetru si identificarea unui scurtcircuit, intrerupere sau conectare eronata
6	Asigurati-va ca capacele rezistente la apa sunt bine stranse.
7	Porturile ramase libere sunt izolate
8	Toate stickerele cu avertismente de pe inverter sunt vizibile si in stare buna

6.2 Procedura de pornire

Urmati urmatoorii pasi:

Intrerupator principal de alimentare
Daca exista comutati-l pe ON (figura este doar de referinta) ①



Intrerupator circuit AC
Comutati-l pe ON (figura este doar de referinta) ②

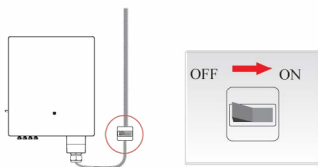

Intreruator DC
Comutati-l pe ON

③

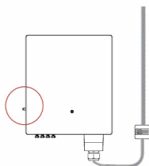

Icoana LED
Albastru aprins (functionare
normala)

④

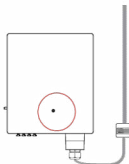

6.3 Procedura de inchidere

Poate fi necesara inchiderea invertorului uneori in timpul zilei. Daca se impune, urmati procedura:

**Intreruator principal
de alimentare**

Daca exista Comutati-l pe OFF
(figura este doar de referinta)

①

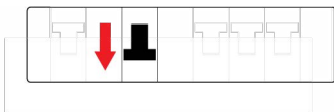

Intreruator circuit AC

Comutati-l pe OFF
(figura este doar de referinta)

②

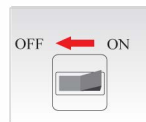
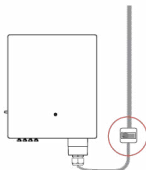

Intrerupator DC
Comutati-l pe OFF
(figura este doar de referinta)

3

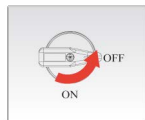
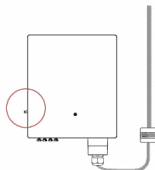

Asteptati cel puțin 5 minute.
Lasati invertorul sa se raceasca
complet

4



AVERTISMENT

Dupa inchiderea invertorului, radiatoarele vor genera caldura si va exista electricitate in invertor. Pentru a evita socurile electrice sau arsurile grave, nu executati nicio lucrare la invertor cel puțin 5 minute dupa inchidere.

7 Interfata cu utilizatorul

Aceasta sectiune descrie panoul LED sau ecranul LCD (optional).

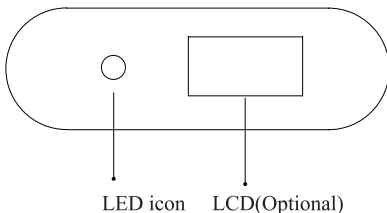

Status LED	Descriere
Albastru clipeste incet 1 data / s	Standby sau pornire (nu este conectat la retea)
Albastru pornit	Conectat la retea
Verde pornit	Status putere limitata
Rosu clipeste incet 1 data / s	Eroare la iesire
Rosu clipeste rapid 4 ori / s	Eroare la intrare
Rosu aprins	Eroare internă
Rosu/ verde/albastru clipeste adauga (1 culoare / 0.25s)	Scriere cod (Master Slave) Setarea controlului puterii (daca dureaza 1 s)

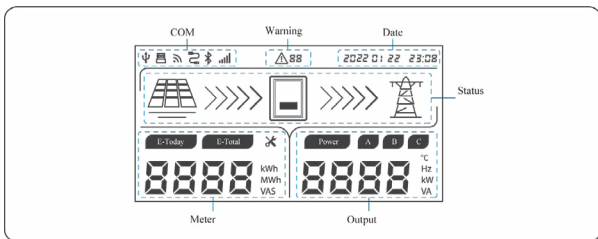

COM

În momentul transferului de date prin WIFI/GPRS/Bluetooth, icoana  va fi pornita, iar cand transferul se incheie icoana se va stinge dupa 10s de inactivitate.

La transferul de date prin RS485, icoana  este aprinsa, iar cand transferul se incheie icoana se va stinge dupa 10s de inactivitate.

Warning

În momentul în care acest avertisment este declansat icoana se va lumina, de la stanga la dreapta prima parte poate fi A/B/C în functie de avertisment urmata de codul de eroare. Pentru a decodifica aceste mesaje consultati tabelul cu avertismente prezentat.

Date

Cand comunicatia functioneaza iar fusul orar este corect, ceasul intern va fi sincronizat cu ora serverului. In lipsa comunicatiei, este necesara folosirea aplicatiei mobile conectata prin Bluetooth la inverter.





Status

Icoana  descrie panourile solare, cand inverterul este in starea Standby, tensiunea MPPT ale panourilor va fi afisata in zona Meter.

Icoana  descrie reseaua/grid, cand tensiunea si frecventa in grid sunt normale, icoana sta aprinsa iar in caz contrar clipeste; cand nu exista tensiune icoana se stinge.

Icoana  descrie directia de curgerea a curentului, cand inverterul este in stare

Meter

Stare normala: Puterea astazi si totala, tensiune MPPT si curentul sunt afisate pe rand	
Standby: numaratoare inversa pentru pornirea inverterului	
Orice stare: setare parametrui prin aplicatie, ecranul se mentine 5 secunde	
Stare normala: puterea la iesire, tensiune si curent in grid, sunt afisate pe rand	

Tabel cu avertismente

Stare	Detalii	Cod avertisment
LED rosu clipeste incet	Grid supratensiune	A0
	Grid sub tensiune	A1
	Fara grid	A2
	Grid supra frecventa	A3
	Grid sub frecventa	A4
	Grid atipic	A6
	Grid tensiune medie mare	A7
Red blink quickly	PV supratensiune	B0
	PV rezistenta la izolare atipica	B1
	Scurgere curent atipic	B2
	Panouri PV atipic	B3
	PV sub tensiune	B4
LED rosu aprins	Control putere atipic	C0
	Eroare arc	C1
	Componenta DC semnificativa pe curentul de iesire	C2
	Releul invertorului atipic	C3
	Invertor temperatura crescuta	C5
	Scurgere curent HCT atipic	C6
	Eroare sistem	C7
	Tensiune DC link neechilibrata	C9
	Supratensiune DC link	CA
	Eroare comunicatie interna	CB
	Incompatibilitate software	CC
	Eroare EEPROM	CD
	Avertisment consistent	CE
	Invertor atipic	CF

LED rosu aprins	Boost atipic	CG
	Master pierdut	CH
	Meter pierdut	CJ
LED albastru clipeste	Ventilator atipic (standby)	C8
	Remote off	CN
LED albastru aprins	Fan atipic (status normal)	C8

NOTA!

In cazul in care aveti un inverter cu ecran LCD aceste coduri vor fi afisate pe ecran, in caz contrar codurile de avertizare vor fi afisate in aplicatia mobila.

8 Depanare si mentenanta



AVERTISMENT

Inainte de verificare si punerea in functiune a inverterului impreuna cu sistemul periferic de distributie, inchideti toate terminalele sub tensiune ale inverterului si asteptati cel putin 10 minute dupa oprirea lui.



PERICOL

- Mentenanta executata prost va rezulta in raniri si distrugerii!
- Inainte de a executa lucrari de mentenanta deconectati intrerupatorul AC de la grid, apoi deconectati intrerupatorul DC.
- Asteptati cel putin 10 min pentru a evita socul electric.
- Utilizati echipament de testare pentru a va asigura ca nu exista tensiune reziduala.



NOTIFICARE

Intrati in conformitate cu specificatiile de protectie ESD si distributia de energie ESD brachelets.

Evitati contactul inutil cu placa de circuite.

Atingerea oricarei placi de circuite sau a componentelor sensibile la incarcările electrostatice vor cauza daune.

8.1 Depanare

Daca invertorul prezinta erori, indicatorul LED se va face rosu.

Informatie alarma	Masuri recomandate
A0-retea supravoltata	<ol style="list-style-type: none">1. Daca alarma se declanseaza ocazional, e posibil ca retea sa fi fost temporar afectata si nu este necesara nicio actiune.2. Daca alarma se declanseaza in mod repetat, contactati furnizorul local de energie pentru a cere aprobare de a face schimbari la parametrii de protectie setati.3. Daca alarma persista verificati: a. Intrerupatorul AC decupleaza frecvent (presiune mare) b. Daca linia de comunicare este realizata dupa manual, impedanta cablului poate cauza sa creasca puterea de la grid. c. Echipamentul trifazic masoara daca tensiunea intre neutru si impamantare depaseste 30V; in caz de depasire retea este in avarie. <p>Daca nu este identificata niciuna din varianta, contactati Suportul Tehnic.</p>
A1-retea subvoltata	<ol style="list-style-type: none">1. Daca alarma se declanseaza ocazional, e posibil ca retea sa fi fost temporar afectata si nu este necesara nicio actiune.2. Daca alarma se declanseaza in mod repetat, contactati furnizorul local de energie pentru a cere aprobare de a face schimbari la parametrii de protectie setati.3. Daca alarma persista verificati: a. Intrerupatorul AC este decuplat sau nu. b. Daca intrerupatorul AC este deteriorat (daca tensiunea in starea inchisa este consistenta cu tensiunea de la priza). c. Terminalele AC sunt in contact perfect. <p>Daca tensiunea masurata este in parametrii acceptati, contactati Suportul Tehnic.</p>

<p>A2-reteaua cazuta</p>	<p>1. Daca alarma se declanseaza ocazional, e posibil ca reteaua sa fi fost temporar afectata si nu este necesara nicio actiune.</p> <p>2. Daca alarma se declanseaza in mod repeteat, contactati furnizorul local de energie pentru a cere aprobare de a face schimbari la parametrii de protectie setati.</p> <p>3. Daca alarma persista verificati:</p> <p>a. Intrerupatorul AC este decuplat sau nu.</p> <p>b. Daca intrerupatorul AC este deteriorat (daca tensiunea in starea inchisa este consistenta cu tensiunea de la priza).</p> <p>c. Terminalele AC sunt in contact perfect.</p> <p>d. Daca reteaua e cazuta.</p> <p>Daca nu este identificata niciuna din variante, contactati Suportul Tehnic.</p>
<p>A3-frecventa retelei prea mare</p>	<p>1. Daca alarma se declanseaza ocazional, e posibil ca reteaua sa fi fost temporar afectata si nu este necesara nicio actiune.</p> <p>2. Daca alarma se declanseaza in mod repeteat, contactati furnizorul local de energie pentru a cere aprobare de a face schimbari la parametrii de protectie setati.</p>
<p>A4-frecventa retelei prea mica</p>	<p>1. Daca alarma se declanseaza ocazional, e posibil ca reteaua sa fi fost temporar afectata si nu este necesara nicio actiune.</p> <p>2. Daca alarma se declanseaza in mod repeteat, contactati furnizorul local de energie pentru a cere aprobare de a face schimbari la parametrii de protectie setati.</p> <p>3. Daca alarma persista, contactati Suportul Tehnic.</p>
<p>A6-anormalitate retea</p>	<p>1. Daca alarma se declanseaza ocazional, e posibil ca reteaua sa fi fost temporar afectata si nu este necesara nicio actiune.</p> <p>2. Daca alarma persista verificati:</p> <p>a. Daca tensiunea trifazica este masurata si se constata dezechilibru de tensiune trifazat mai mare de 30%, va rugam luati legatura cu furnizorul dvs. pentru imbunatatirea parametrilor retelei</p> <p>b. Intrerupatorul circuitului AC trifazic este deteriorat (indiferent daca este tensiunea liniei de intrare și de iesire a prizei sunt egale).</p> <p>c. Daca intrerupatorul de curent alternativ instalat are nul sau nu. Posibil nulul sa fie intrerupt.</p> <p>Daca alarma persista, contactati Suportul Tehnic.</p>
<p>B0-PV supra-tensiune</p>	<p>Verificati daca tensiunea a unui singur sir de panouri depaseste tensiunea MPPT acceptata.</p> <p>Daca tensiunea maxima depaseste tensiunea standard, modificati numarul de panouri pe sir.</p>
<p>B1 -PV izolare atipica</p>	<p>1. Daca alarma se declanseaza ocazional, invertorul poate genera electricitate. Verificati sa nu existe componente umede sau umiditatea din aer sa nu fie prea mare.</p> <p>2. Daca alarma de declanseaza in mod repetat, invertorul genereaza ocazional energie. Verificati daca polaritatea +/- a panourilor nu prezinta scurtcircuit, un component este deteriorat sau cablul de conectare este intrerupt.</p> <p>3. Daca alarma continua, invertorul nu poate genera electricitate, contactati Suportul Tehnic.</p>

B2-Scurgere anormala de curent	<ol style="list-style-type: none"> 1. Daca alarma se declanseaza ocazional, e posibil ca retea sa fi fost temporar afectata si nu este necesara nicio actiune. 2. Daca alarma se declanseaza frecvent si este acompaniata de alarma de izolatie slaba, verificati izolatia. 3. Daca alarma persista, contactati Suportul Tehnic.
B4-PV sub tensiune	<ol style="list-style-type: none"> 1. Daca alarma se declanseaza cand lumina solara este slaba (dimineata devreme, seara, vreme extrema sau furtuni de praf) tensiunea este mai mica decat normalul. Nu se vor lua alte masuri. 2. Daca alarma se declanseaza cand lumina solara este slaba verificati daca grupul de panouri prezinta scurtcircuit, circuit deschis au nu.
B5-PV iluminare slaba	<ol style="list-style-type: none"> 1. Daca alarma se declanseaza cand lumina solara este slaba (dimineata devreme, seara, vreme extrema sau furtuni de praf) fenomenul este normal.
B7-PV sir inversat	Verificati si modificati polaritatea la intrarea sirului.
C0 Sursa de tensiune internă anormală	<ol style="list-style-type: none"> 1. Daca alarma se declanseaza ocazional, invertorul se redreseaza automat. Nu se vor lua alte masuri. 2. Daca alarma se declanseaza frecvent, invertorul nu functioneaza corect. Contactati Suportul Tehnic.
C2- Curentul dc-bias al invertorului prea mare	<ol style="list-style-type: none"> 1. Daca alarma se declanseaza ocazional, invertorul se redreseaza automat. Nu se vor lua alte masuri. 2. Daca alarma se declanseaza frecvent, invertorul nu functioneaza corect. Contactati Suportul Tehnic.
C3-Releu invertor anormal	<ol style="list-style-type: none"> 1. Daca alarma se declanseaza ocazional, invertorul se redreseaza automat. Nu se vor lua alte masuri. 2. Daca alarma se declanseaza frecvent in cazul invertorului monofazat verificati daca faza si neutrul este inversat; in cazul invertorului trifazat verificati faza si neutrul si tensiunea dintre faza si impamantare. <p>Daca partea din spre grid este normala, contactati Suportul Tehnic.</p>
C5-temperatura ridicata a invertorului	<ol style="list-style-type: none"> 1. Daca alarma se declanseaza ocazional, invertorul se redreseaza automat. Nu se vor lua alte masuri. 2. Daca alarma se declanseaza frecvent verificati ca instalatia sa nu fie in bataia directa a soarelui, sa fie ventilata corect sau daca nu este afectata de temperatura ambientală mare (invertor instalat pe un perete sau parapet exterior). Daca temperatura ambientală este mai mica de 45° C si caldura se disipa corect, contactati Suportul Tehnic.
C6-GFCI defect	<ol style="list-style-type: none"> 1. Daca alarma se declanseaza ocazional, poate fi vorba de o situatie exceptionala, Nu se vor lua alte masuri. 2. Daca alarma se declanseaza frecvent sau nu se redreseaza dupa o perioada indelungata, contactati Suportul Tehnic.
C7- eroare sistem	<p>Daca se declanseaza alarma invertorul nu functioneaza corect, va rugam restartati invertorul.</p> <p>Daca alarma se declanseaza iar, contactati Suportul Tehnic.</p>

C8 - ventilator defect	<p>1. Daca alarma se declanseaza ocazional, reporniti invertorul.</p> <p>2. Daca alarma se declanseaza frecvent sau pe perioade lungi de timp ventilatorul exterior este blocat.</p> <p>Daca nu este cazul, Contactati Suportul Tehnic.</p>
C9- tensiunea DC-link dezechilibrata	<p>1. Daca alarma se declanseaza ocazional, invertorul se redreseaza automat. Nu se vor lua alte masuri.</p> <p>2. Daca alarma se declanseaza frecvent, invertorul nu functioneaza corect. Contactati Suportul Tehnic..</p>
CA- supratensiune dc-link 1	
CB-eroare la comunicarea internă	
CC-Software incompatibil	
CD-Eroare stocare internă	
CE- Inconsistența date	
CF-defectiune inverter	
CG -Boost anormal	
Datele de monitorizare nu sunt la zi	
Monitorizarea la distanță prezintă iconița invertorului galbenă	<p>1. Invertorul funcționează normal. Acest fapt nu necesită intervenție.</p> <p>2. Dacă starea invertorului este normală verificați dacă întrerupătorul AC este închis.</p>
Niciun indicator afișat pe inverter	<p>Verificați ca tensiunea la intrare să fie normală, mai mică de 120V.</p> <p>Dacă este, contactați Suportul Tehnic.</p>
Energie generată mică	<p>1. Verificați dacă energia afișată de meter este aceeași cu cea din datele de monitorizare.</p> <p>2. Verificați componentele deoarece această scădere poate fi cauzată de praf, blocaje, întreruperi etc.</p> <p>3. Verificați datele de monitorizare pentru a confirma dacă invertorul este conectat la internet deoarece dacă alarma se oprește frecvent, există o problemă care are nevoie de rezolvare.</p>

Informația despre cum invertorul este conform cu specificațiile standardului AS/NZS 5033 legată de alarma erorii la împământare.

8.2 Mentenanta

Mentenanta periodica a invertorului

Obiect de verificat	Detalii de verificat	Actiune	Interval
Stare iesire invertor	Monitorizati cantitatea generata periodic si alarmele aparute	N/A	Saptamanal
Infatisare invertor	Verificati ca radiatorul sa nu fie plin de praf	Curatati radiatorul	Anual
Stare functionare invertor	a. Verificati ca invertorul sa nu fie deteriorat sau deformat b. Verificati sunetele emise de invertor in timpul functionarii. c. Verificati conexiunile de comunicare si functionalitatea lor	In caz de comportament atipic, interveniti	Lunar
Conexiuni electrice invertor	a. Verificati cablurile AC, DC si cele de comunicare daca sunt conectate corespunzator. b. Verificati cabluri de impamantare PGND daca sunt conectate corespunzator c. Verificati cablajul de semne de deteriorare	In caz de comportament atipic, interveniti	2 ori pe an

Mentenanta ventilator

Daca ventilatorul extern nu functioneaza corect, va cauza incalzirea invertorului si ineficienta sa. Mentineti ventilatorul curat si schimbati-l periodic.

Pasul 1. Inchideti invertorul

Pasul 2. Verificati documentatia electrica de conectare a invertorului si deconectati-l folosindu-va de pasi in ordine inversa.

Pasul 3. Verificati documentatia aferenta instalarii mecanice si indepartati-l folosindu-va de pasi in ordine inversa.

Pasul 4. Desfaceti cele 2 suruburi de securizare de pe suportul ventilatorului.

Pasul 5. Utilizand o pensula moale curatati ventilatorul. Daca il inlocuiti ujtizati o surubelnita sa indepartati vechiul ventilator din suportul sau.

Pasul 6. Instalati noul ventilator si porniti sistemul.



Dezafectarea echipamentelor electrice si electronice vechi

(Se aplica pentru țările membre ale Uniunii Europene si pentru alte țări europene cu sisteme de colectare separata)

Acest simbol aplicat pe produs sau pe ambalajul acestuia indica faptul ca acest produs nu trebuie tratat ca pe un deșeu menajer.

El trebuie predat punctelor de reciclare a echipamentelor electrice si electronice.

Asigurandu-va ca acest produs este dezafectat in mod corect, veți ajuta la prevenirea posibilelor consecințe negative asupra mediului si a sanatatii umane, care ar fi putut surveni daca produsul ar fi fost dezafectat in mod necorespunzator.

Reciclarea materialelor va ajuta la conservarea resurselor naturale.

