



Air2-ODI100W
Dual PIR wireless detector
for outdoor use

Installation and programming manual



GameOver

Table of contents

1	General information	3
1-1	About this manual	3
1-2	Manufacturer's details	3
1-3	Description of the product	3
1-4	Package contents	5
2	Functioning	5
2-1	Detection range	5
2-2	Operating principles	6
2-3	"Test" function	7
2-4	"Inhibition" function	7
3	Installation	7
3-1	Placement	7
3-2	Installation procedure	8
4	Programming	9
5	Maintenance and periodic checks	9
6	Disposal and scrapping	9
	Simplified EU Declaration of Conformity	10

The information contained in this document is the sole property of INIM Electronics s.r.l. No part may be copied without written authorization from INIM Electronics s.r.l.

All rights reserved.

Informative notice regarding the disposal of electrical and electronic equipment (applicable in countries with differentiated waste collection systems)

The crossed-out bin symbol on the equipment or on its packaging indicates that the product must be disposed of correctly at the end of its working life and should never be disposed of together with general household waste.

The user, therefore, must take the equipment that has reached the end of its working life to the appropriate civic amenities site designated to the differentiated collection of electrical and electronic waste.

As an alternative to the autonomous-management of electrical and electronic waste, you can hand over the equipment you wish to dispose of to a dealer when purchasing new equipment of the same type. You are also entitled to convey for disposal small electronic-waste products with dimensions of less than 25cm to the premises of electronic retail outlets with sales areas of at least 400m², free of charge and without any obligation to buy.

Appropriate differentiated waste collection for the subsequent recycling of the discarded equipment, its treatment and its environmentally compatible disposal helps to avoid possible negative effects on the environment and on health and favours the re-use and/or recycling of the materials it is made of.

Information about disposal of batteries and accumulators (applicable in Countries with separate collection systems)

This marking on batteries and/or their manual and/or their packaging, indicates that batteries of these products, at the end of their working life, should not be disposed of as unsorted municipal waste, but must be object of a separate collection. Where marked, the chemical symbols Hg, Cd o Pb indicate that the battery contains mercury, cadmium or lead above the reference levels of the directive 2006/66/EC. If batteries are not properly disposed of, these substances, together with other ones contained, can cause harm to human health and to the environment.

To protect human health and the environment, to facilitate treatment and recycling of materials, separate batteries from other kind of waste and use the collection scheme stated in your area, in accordance to current laws.

Before disposing of the above, it's appropriate to remove them from their holders avoiding to damage them or causing short circuits.

Copyright

WEEE



GENERAL INFORMATION 1

About this manual 1-1

Double technology wireless detector for outdoor use (IN10 and IN11) installation manual	DESCRIPTION
DCMIINIEA2ODI100W	MANUAL CODE
1.30	VERSION

Manufacturer's details 1-2

Manufacturer:	INIM ELECTRONICS S.R.L.
Production plant:	Centobuchi, via Dei Lavoratori 10 63076, Monteprandone (AP), Italy
Tel.:	+39 0735 705007
Fax:	+39 0735 704912
e-mail:	info@inim.biz
Web:	www.inim.biz

The persons authorized by the manufacturer to repair or replace the parts of this system, hold authorization to work on INIM Electronics brand devices only.

Description of the product 1-3

- Wireless detector for outdoor use
- Air2 two-way wireless intrusion protection system (868MHz frequency)
- Dual PIR infrared sensors, low consumption and UV filter
- UV resistant Fresnel lens
- Low consumption, power supply range 3 to 9V ---
- "Test" function to signalling each alarm by LED blinking; auto power off after 4 minutes
- Tamper and dislodgement system
- Inhibition LED and transmitting function for battery life saving (always on)
- AND/OR selectable function
- Mechanism for horizontal coverage adjustment
- Precision adjustment of lower beam (patented)
- Stainless steel pole brackets (not supplied)
- UV resistant polycarbonate casing

Table 1: Air2-ODI100W technical features

Power-supply	from 3 to 9V ---
Stand-by current	12 μ A
Maximum current	25mA
Detection range	from 3 to 12m
Horizontal coverage angle	60°
Horizontal coverage adjustment	+/- 45°
IP protection degree	IP44
Working temperature	from -20° to 55°C
Dimensions	189x81x95 mm
Weight (only detector)	450g
Battery	Lithium CR17450 3V (2)
Battery life	4 years

The manufacturer cannot guarantee the declared battery life.

Note

Table 2: Mechanical parts description

A	"U" shaped bracket
B	"L" shaped bracket
C	Hermetic casing base
D	Electronic holder (sensors in front and transceiver on the back)
E	Cover with Fresnel lens
F	Lower PIR range adjustment knob
G	Anti tamper microswitch
H	Electronics and sensors
I	"O-ring" gasket
J	Cover enclosure screw
K	Inner screw for "L" and "U" brackets fixing
L	External screw for "L" and "U" brackets fixing
M	Base enclosure screw

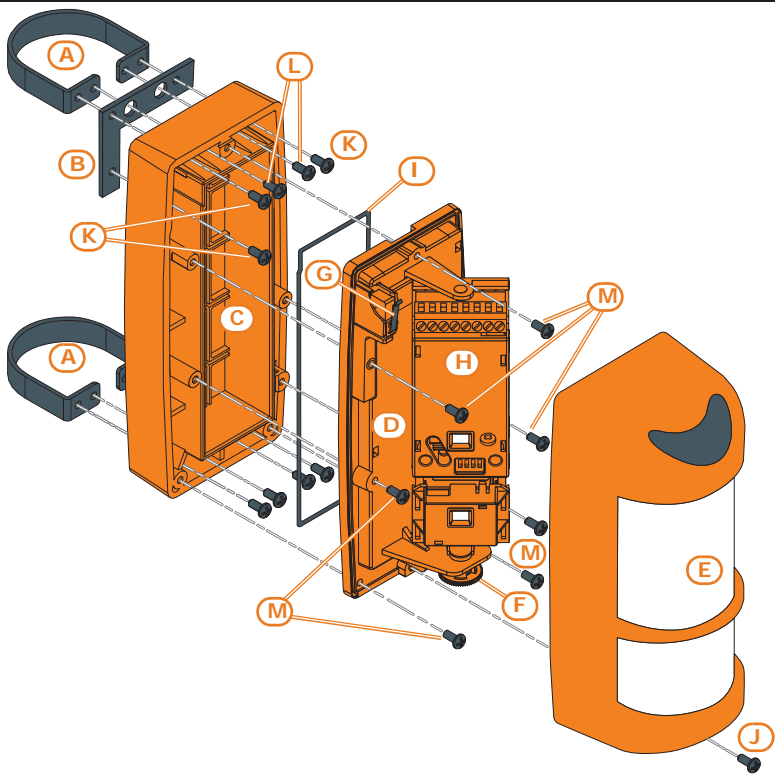
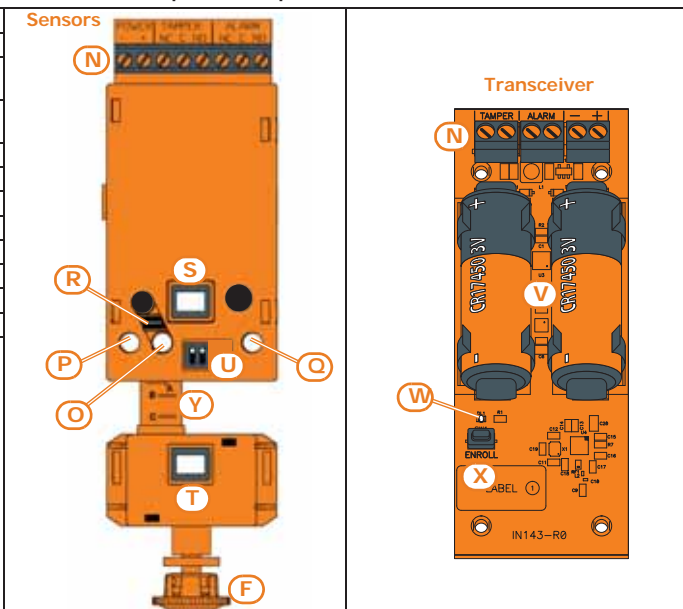

Table 3: Electronic part description

N	Terminal board for wire connection
O	Red LED for radio transmission
P	Left green LED for each higher PIR detection
Q	Right green LED for each lower PIR detection
R	Jumper
S	Higher infrared sensor (PIR 1)
T	Lower infrared sensor (PIR 2)
U	DIP switches
V	Batteries
W	Transmission green LED
X	ENROLL button
Y	PIR 2 marked positions



The Air2-ODI100W detector communicates with INIM intrusion control panel via the Air2 two-way wireless intrusion protection system.

Table 4: Technical specifications of Air2 system

Operating frequency	range	868.0 - 868.6MHz
	selectable channels	868.1, 868.3, 868.5MHz
Maximum RF output power		25mW e.r.p.
Communication type		Two-way
Modulation		GFSK
Device supervision		From 12 to 250 minutes

Package contents 1-4

Inside the package you will find:

- Air2-ODI100W detector
- Hermetic casing base
- Installing manual (this)
- Plastic bag containing:
 - 6 stainless steel metric screw M3 x 20
 - 4 anchor screws and plugs for wall mounting
 - "O ring" gasket

Items not included in the package (accessory items to be purchased separately):

- "U" shaped brackets
- "L" shaped brackets

FUNCTIONING 2

Detection range 2-1

Table 5: Top view

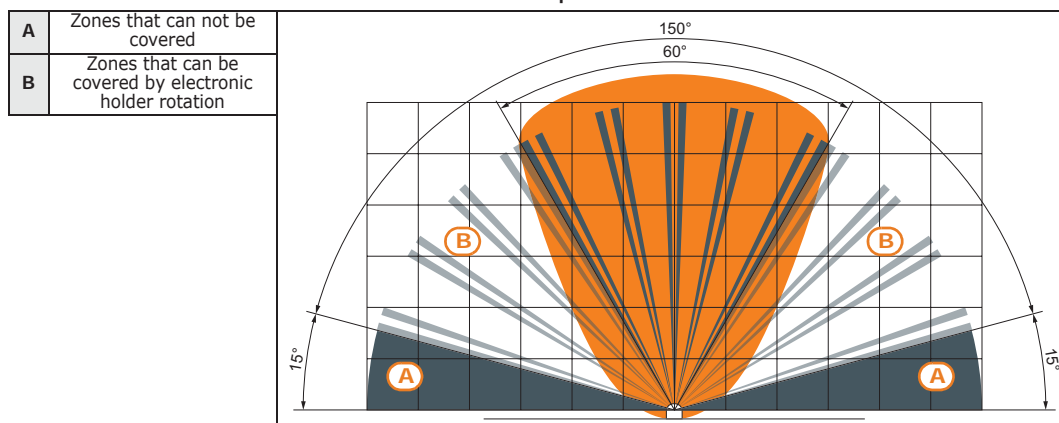

By using the knob (*table 2, F*) it is possible to move the PIR2 (lower) in order to obtain different ranges from 3m to 12m. **ADJUSTMENT**

The knob moves vertically the RIP along the marked positions on the holder (*table 3, Y*). Each position corresponds to a distance:

Table 6: Side view

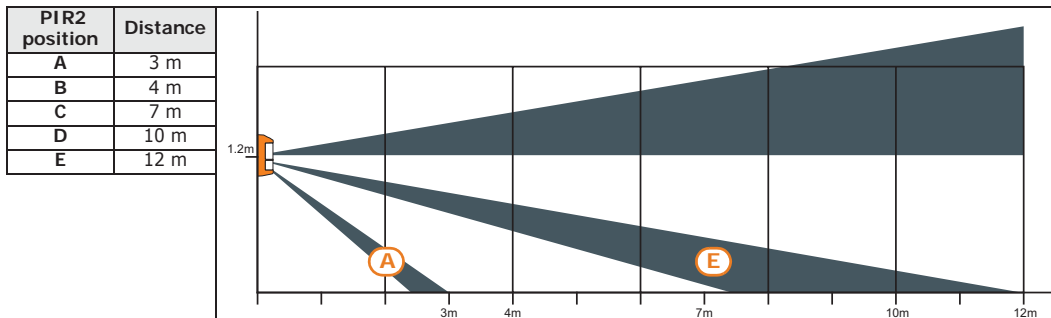

These distances are reached when the detector is installed at about 120cm (height).

Operating principles 2-2

The detector operates in the AND mode of PIRs generating an alarm when both sensors detect a presence.

The figures below shows some of most relevant working examples.

Table 7: Working examples

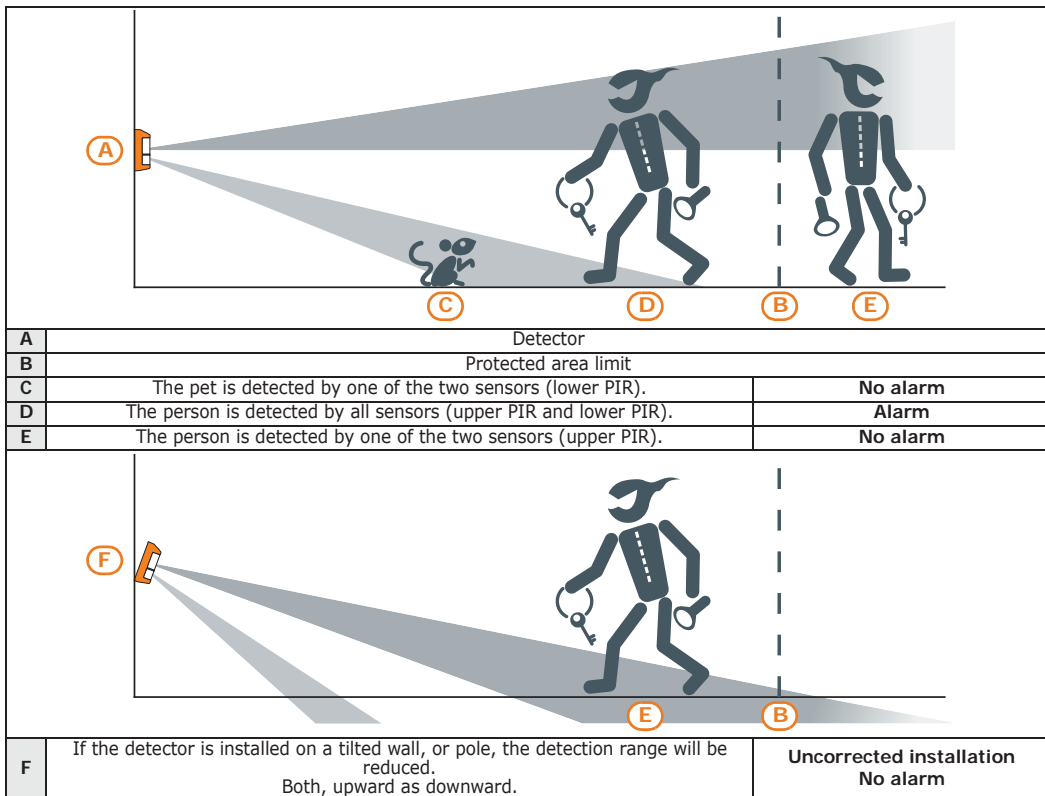

“Test” function 2-3

This function has been implemented in order to make the detector easy to set up.

The function can be activated disconnecting and connecting again the jumper (table 3, R); within a minute the function will be operative. In this mode the LED will be lighted for each detection. Below the meanings of the LEDs:

- **Red LED** (table 3, O): switch on when there is an alarm or tamper situation.
- **Left green LED** (table 3, P): switch on when the upper PIR detects a motion.
- **Right green LED** (table 3, Q): switch on when the lower PIR detects a motion.

After about 4 minutes the test mode is automatically switched off, and the LED are deactivated (paragraph 2-4 “Inhibition” function).

Be sure to have screwed up the cover with Fresnel lens before perform the tests. LEDs activation can be seen through the lens.

Note

Once performed detection and radio transmission range tests, the detector is ready to work.

LEDs are active only in test mode.

Note

In working mode the LEDs are automatically deactivated. In order to verify if the detector is working properly, remove the front cover disconnect and connect again the jumper to activate the testing mode; at the end screw the cover up.

“Inhibition” function 2-4

In working mode (LEDs deactivated) the function inhibition is automatically activated in order to safe battery life. This implies that if the detector has been installed in a populated area, the detector will no switch the alarm relay if the detection area is free for three minutes at least.

This function avoid that the detector triggers the alarm relay continuously.

In order to verify if the detector is working properly, wait at least three minutes after each detection.

INSTALLATION 3

It is important to evaluate the installation site previously. Bush close to the detector might cause false alarm. **WARNING**

The detector is equipped with UV filters in order to avoid problems due to sunshine rays. Anyway, if it is possible, do not direct the detector versus the sun.

Placement 3-1

Start the “test” mode (paragraph 2-3 “Test” function), in order to obtain a real simulation, keep out the protected area, and avoid any crossing into it.

After 30÷40 seconds without events, come in to the detection area and, looking the red LED, verify if the detector works correctly.

After the detection, wait at least 7÷8 seconds before the next detection. Refer to the coverage diagram to estimate the detection area (table 5 “Top view” and table 6 “Side view”).

Environmental conditions are important elements to be evaluated during the installation. Bump, bottomland or slops can modify the performances of the detector.

If into the detection area any medium size animal can walk, it is suggested to choose carefully the installation height in order to avoid false alarms.

The maximum coverage range, 12m, is reached when the detector is installed at about 120cm (height).

Do not obscure partially or completely the detector’s field of view.

Place the detector no less than 2m away from the Air2-BS200 transceiver.

Note

Installation procedure 3-2

1. Unscrew the screw for the cover enclosure (*table 2, J*).
2. Remove the cover with lens (*table 2, E*).
3. Unscrew the fixing screws (*table 2, M*) of the detector to the waterproof rear casing.
4. Fix the hermetic casing (*table 2, C*) on the wall, or on a pole (be sure the pole is stable and ripple free).
5. Fix the "L" shape bracket (*table 2, B*) behind the hermetic casing with one screw (*table 2, K*).

Use the upper hole to fix the case to the "L" shaped bracket.

6. Position the two "U" (*table 2, A*) shaped bracket around the pole.
7. Block them with the inner screws (*table 2, L*) and the external screws (*table 2, K*).
5. Perforate the wall in correspondence of the holes on the casing.
6. Insert the wall plugs into the holes.
7. Screw up the case with the screws. Pay attention to not damage anti tamper switch support knock-out.

Use the lower hole to fix the hermetic casing on the wall.

8. Enroll the detector (refer to Air2-BS200 transceiver installation manual).
9. Insert the o-ring gasket (*table 2, I*) into its seat located on the electronic holder (*table 2, D*).

Pay attention to not stretch out the o-ring gasket during its installation.

10. Couple the detector and the hermetic casing then screw (*table 2, M*).
11. Run the range settings (PIR 2 position adjustment and PIRs sensitivity). See *paragraph 2-1 Detection range*.
12. Close the detector with the front cover with Fresnel lens as shown opposite.
13. Screw up the metric screw (*table 2, J*).
14. Wait 30 seconds without moving the detector.
15. Proceed with the verification and programming phases.

POLE FIXING

Note

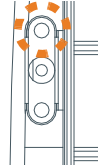

WALL FIXING

Note

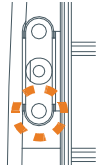

Note

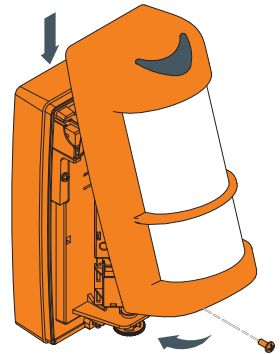

PROGRAMMING

4

In order to make the detector suitable for outdoor applications, a single sensor adjustment system has been implemented.

In the tables below are shown the DIP switch configurations (*table 3, U*):

Table 8: Infrared sensitivity adjustment

	OFF	ON
DIP 1	PIR 1 sensitivity LOW	PIR 1 sensitivity HIGH
DIP 2	PIR 2 sensitivity LOW	PIR 2 sensitivity HIGH

MAINTENANCE AND PERIODIC CHECKS

5

Keep the lens clean to guarantee proper operation of the detector. A lens which is not perfectly clean may cause detection problem. The cleaning must be done when necessary or when clearly dirty.

Clean the lid and the lens with a cloth dampened with water. Wipe with a dry cloth.

Do not use chlorine-based or abrasive products or alcohol to remove particularly noticeable dirt.

CLEANING PROCEDURE

ATTENTION!

DISPOSAL AND SCRAPPING

6

1. Unscrew the screws that fasten the front lid and remove it.
2. Disconnect the detector; disconnect all the terminals on the terminal block.
3. Divide the parts by type and dispose of them in accordance with applicable laws.

DISMANTLING

Do not dispose of the components or any other product material in the environment. Seek the assistance of companies authorised to dispose of and recycle waste materials.

ATTENTION!

SIMPLIFIED EU DECLARATION OF CONFORMITY

Hereby, INIM ELECTRONICS S.R.L. declares that the radio equipment type Air2-ODI100W is in compliance with Directive 2014/53/EU.

The full text of the EU declaration of conformity is available at the following internet address: www.inim.biz.

BG: С настоящото INIM ELECTRONICS S.R.L. декларира, че този тип радиосъоръжение Air2-ODI100W е в съответствие с Директива 2014/53/ЕС.

Цялостният текст на ЕС декларацията за съответствие може да се намери на следния интернет адрес: www.inim.biz

CS: Tímto INIM ELECTRONICS S.R.L. prohlašuje, že typ rádiového zařízení Air2-ODI100W je v souladu se směrnicí 2014/53/EU.

Úplné znění EU prohlášení o shodě je k dispozici na této internetové adrese: www.inim.biz

DA: Hermed erklærer INIM ELECTRONICS S.R.L., at radioudstyrstypen Air2-ODI100W er i overensstemmelse med direktiv 2014/53/EU. EU-overensstemmelseserklæringens fulde tekst kan findes på følgende internetadresse: www.inim.biz

DE: Hiermit erkläre INIM ELECTRONICS S.R.L., dass der Funkanlagentyp Air2-ODI100W der Richtlinie 2014/53/EU entspricht.

Der vollständige Text der EU-Konformitätserklärung ist unter der folgenden Internetadresse verfügbar: www.inim.biz

ET: Käesolevaga deklaratsioon INIM ELECTRONICS S.R.L., et käesolev raadioseadme tüüp Air2-ODI100W vastab direktiivi 2014/53/EL nõuetele.

ELi vastavusdeklaratsiooni täielik tekst on kättesaadav järgmisel internetiaadressil: www.inim.biz

EL: Με την παρούσα ο/η INIM ELECTRONICS S.R.L., δηλώνει ότι ο ραδιοεξοπλισμός Air2-ODI100W πληροί την οδηγία 2014/53/ΕΕ.

Το πλήρες κείμενο της δήλωσης συμμόρφωσης ΕΕ διατίθεται στην ακόλουθη ιστοσελίδα στο διαδίκτυο: www.inim.biz

ES: Por la presente, INIM ELECTRONICS S.R.L. declara que el tipo de equipo radioeléctrico Air2-ODI100W es conforme con la Directiva 2014/53/UE.

El texto completo de la declaración UE de conformidad está disponible en la dirección Internet siguiente: www.inim.biz

FI: INIM ELECTRONICS S.R.L. vakuuttaa, että radiolaitetyypin Air2-ODI100W on direktiivin 2014/53/EU mukainen.

EU-vaatimusten mukaisuusvakuutuksen täysimittainen teksti on saatavilla seuraavassa internetosoitteessa: www.inim.biz

FR: Le soussigné, INIM ELECTRONICS S.R.L., déclare que l'équipement radioélectrique du type Air2-ODI100W est conforme à la directive 2014/53/UE.

Le texte complet de la déclaration UE de conformité est disponible à l'adresse internet suivante: www.inim.biz

HR: INIM ELECTRONICS S.R.L. ovime izjavljuje da je radijska oprema tipa Air2-ODI100W u skladu s Direktivom 2014/53/EU.

Cjeloviti tekst EU izjave o skladnosti dostupan je na sljedećoj internetskoj adresi: www.inim.biz

HU: INIM ELECTRONICS S.R.L. igazolja, hogy a Air2-ODI100W típusú rádióberendezés megfelel a 2014/53/EU irányelvnek.

Az EU-megfelelőségi nyilatkozat teljes szövege elérhető a következők internetes címen: www.inim.biz

LT: Aš, INIM ELECTRONICS S.R.L., patvirtinu, kad radijo įrenginių tipas Air2-ODI100W atitinka Direktyvą 2014/53/ES.

Visas ES atitikties deklaracijos tekstas prieinamas šiuo interneto adresu: www.inim.biz

LV: Ar šo INIM ELECTRONICS S.R.L. deklarē, ka radioiekārta Air2-ODI100W atbilst Direktīvai 2014/53/ES.

Pilns ES atbilstības deklarācijas teksts ir pieejams šādā interneta vietnē: www.inim.biz

MT: B'dan, INIM ELECTRONICS S.R.L., niddikjara li dan it-tip ta' tagħmir tar-radju Air2-ODI100W huwa konformi mad-Direttiva 2014/53/UE.

It-test kollu tad-dikjarazzjoni ta' konformità tal-UE huwa disponibbli f'dan l-indirizz tal-Internet li ġej: www.inim.biz

NL: Hierbij verklaar ik, INIM ELECTRONICS S.R.L., dat het type radioapparatuur Air2-ODI100W conform is met Richtlijn 2014/53/EU.

De volledige tekst van de EU-conformiteitsverklaring kan worden geraadpleegd op het volgende internetadres: www.inim.biz

PL: INIM ELECTRONICS S.R.L. niniejszym oświadczam, że typ urządzenia radiowego Air2-ODI100W jest zgodny z dyrektywą 2014/53/UE.

Pełny tekst deklaracji zgodności UE jest dostępny pod następującym adresem internetowym: www.inim.biz

PT: O(a) abaixo assinado(a) INIM ELECTRONICS S.R.L. declara que o presente tipo de equipamento de rádio Air2-ODI100W está em conformidade com a Diretiva 2014/53/UE.

O texto integral da declaração de conformidade está disponível no seguinte endereço de Internet: www.inim.biz

RO: Prin prezenta, INIM ELECTRONICS S.R.L. declară că tipul de echipamente radio Air2-ODI100W este în conformitate cu Directiva 2014/53/UE.

Textul integral al declarației UE de conformitate este disponibil la următoarea adresă internet: www.inim.biz

SK: INIM ELECTRONICS S.R.L. týmto vyhlasuje, že rádiové zariadenie typu Air2-ODI100W je v súlade so smernicou 2014/53/EÚ.

Úplné EÚ vyhlásenie o zhode je k dispozícii na tejto internetovej adrese: www.inim.biz

SL: INIM ELECTRONICS S.R.L. potrjuje, da je tip radijske opreme Air2-ODI100W skladen z Direktivo 2014/53/EU.

Celotno besedilo izjave EU o skladnosti je na voljo na naslednjem spletnem naslovu: www.inim.biz

SV: Härmed försäkrar INIM ELECTRONICS S.R.L. att denna typ av radioutrustning Air2-ODI100W överensstämmer med direktiv 2014/53/EU. Den fullständiga texten till EU-försäkran om överensstämmelse finns på följande webbadress: www.inim.biz

Notes

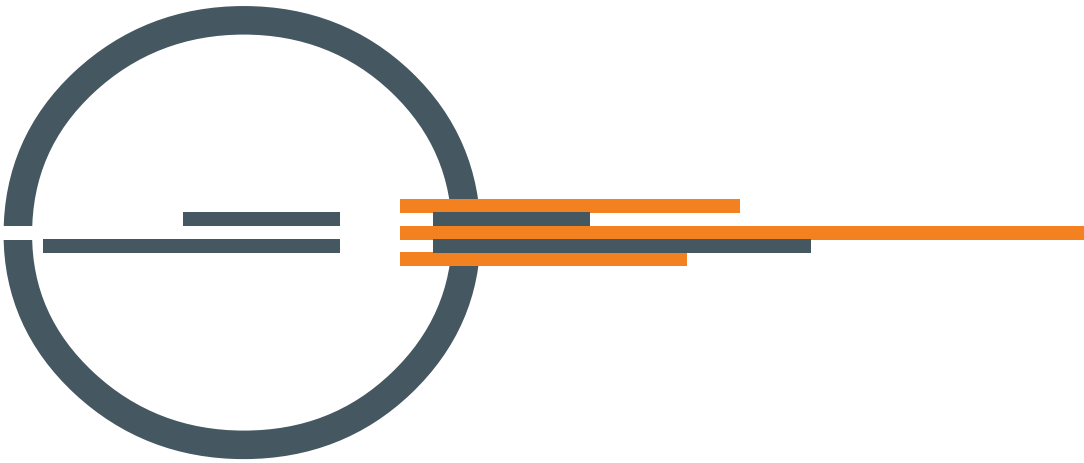

ISO 9001 Quality Management
certified by BSI with certificate number FM530352

Centobuchi, via Dei Lavoratori 10
63076 Montepredone (AP) Italy
Tel. +39 0735 705007 _ Fax +39 0735 704912

info@inim.biz _ www.inim.biz