

REDWALL® INSTALLATION INSTRUCTIONS

Unrivaled performance

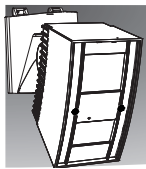

Synthesized Intelligent PIR



REDWALL-V series

FEATURES

- * Intelligent PIR Detection System
 - Three dual pyro-elements with patented Double Conductive Shielding
 - Detection of ambient temperature and illuminance for automatic sensitivity management
 - Advanced detection algorithm
- * Anti-vandalism functions
 - Max.4 m (13 ft.) installation height
 - Anti-rotation with 3-axis accelerometer
 - Anti-masking with photo-beam
- * Sensitivity selector for near/far area independently
- * Detection logic selector
- * Detection range selector
- * Independent N.C. and N.O. ALARM output
- * Adjustable alarm interval time
- * Reinforced polycarbonate housing

REDWALL-V



: Synthesized Intelligent PIR with creep zone

- SIP-3020/5
- SIP-4010/5
- SIP-404/5

1 PARTS IDENTIFICATION

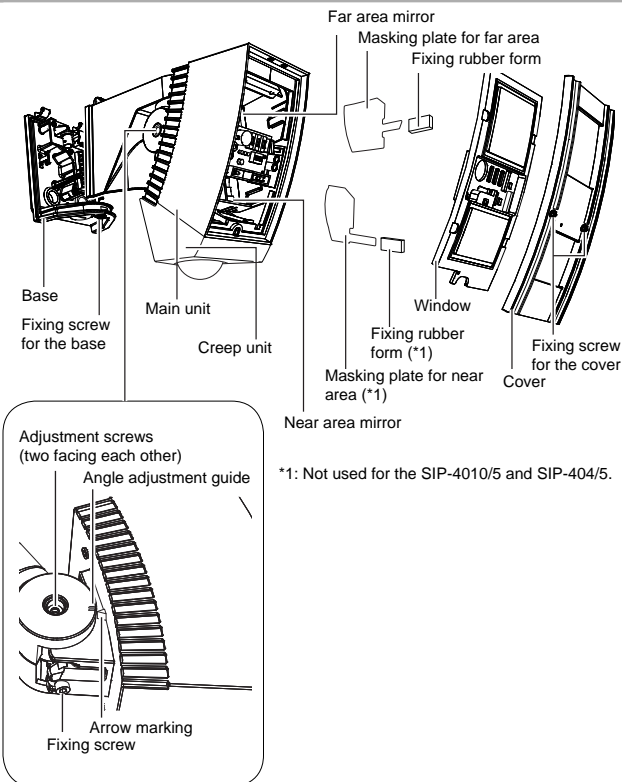

2 INSTALLATION AND MAINTENANCE NOTES

⚠Warning	⚠Caution
<p>Never repair or modify product</p>	<p>Hold the main unit securely when you install or service it. If you remove your hands from the main unit when cables are connected to it, the main unit may fall and the connector cables may break or the circuit board may be damaged.</p>
<p>Verify that the power is off before connecting the wiring.</p>	<p>When servicing, the sensor can be hooked onto the base using the nylon wire loop.</p>

2-1 INSTALLATION HINTS

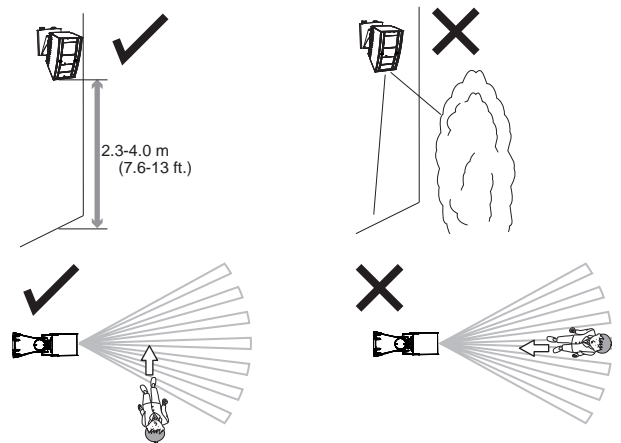

3 INSTALLATION AND ANGLE ADJUSTMENT

3-1 Wall Mounting

- (1) Attach the paper template (an accessory) onto the wall, and drill a 6-mm dia. mounting hole and a cabling hole. Insert the anchor bolt (an accessory) into the board mount hole.

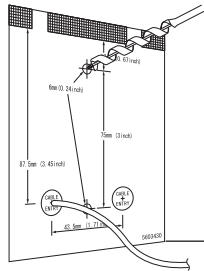

Distance from the ground to the bottom of the template must be between 2.3 m (7.6 ft.) and 4 m (13 ft.).

- (2) Using an allen key, remove the main unit from the base.

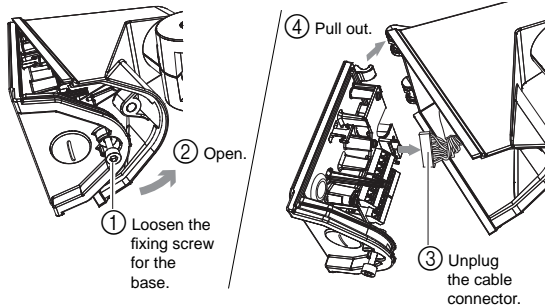

- (3) Drill through the bushing of the wiring hole, pass the cable through the hole, and secure the base to the wall.

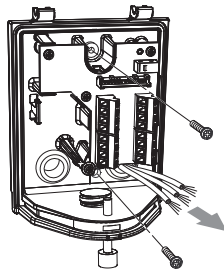

- (4) Connect the cable to the terminal block (see Step 3-3).

- (5) Mount the main unit onto the base.

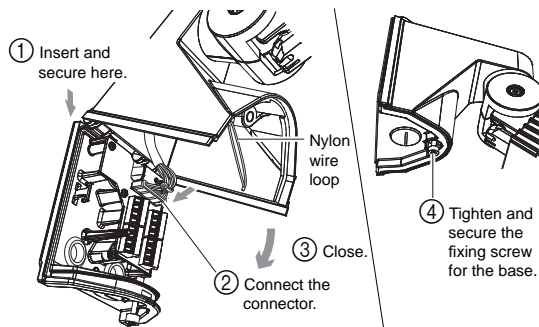

Cautions>>

When mounting the main unit, take care not to trap the nylon wire loop. Also, take care not to get your fingers caught.

- (6) Check to see that the various settings and operations are correct.

Caution>>

When the red LED flashes after the power turns on, this signifies that the system is warming up. Wait for approximately 60 seconds.

3-2 Inside View of the Base

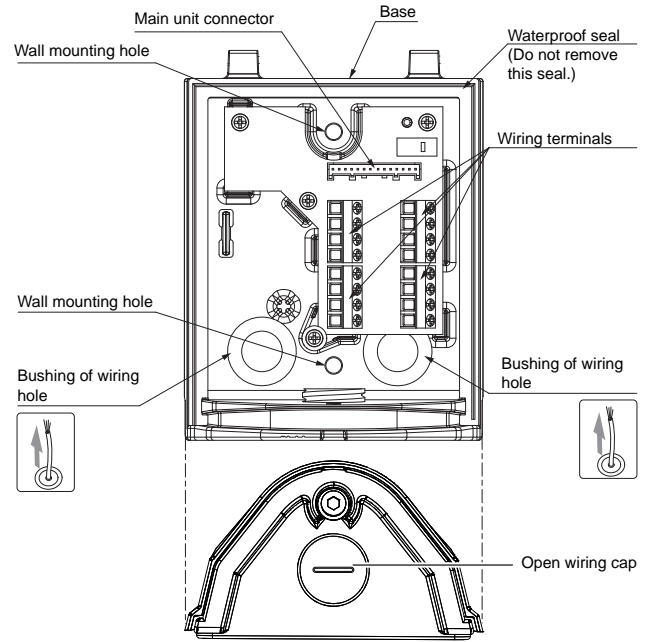

3-3 WIRING

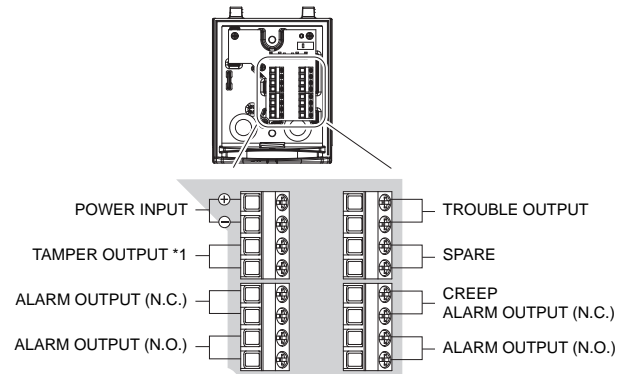

*1: TAMPER terminals to be connected to a 24 hour supervisory loop.

Name	Function
TROUBLE OUTPUT	Trouble out is used for anti-masking signal. When an object is placed close to the lens surface, for a period of more than 20 seconds (approx.), the IR anti-masking circuit will activate and generate a trouble signal.
TAMPER OUTPUT	It is detected when the cover is opened. It is detected when the main unit is removed from its base. Anti-Rotation: Damage sustained by the main unit is detected. When the system power switch is turned on while the cover is closed, the mounting position of the main unit itself will be determined and stored in memory after approximately 10 seconds. Then, if the main unit is impacted in a horizontal or vertical direction and if the position of the main unit has changed, damage sustained by the main unit will be detected. However, if you remove the cover while keeping the system power turned on, and if you close the cover again after correcting the position of the main unit, the new position of the main unit will be stored in memory after approximately 10 seconds.

Power wires should not exceed the following lengths.

WIRE GAUGE	SIP-3020/5, SIP-4010/5, SIP-404/5		
	12V DC	14V DC	24V AC
0.33 mm ² (AWG22)	580 (1900)	770 (2530)	1370 (4490)
0.52 mm ² (AWG20)	910 (2990)	1210 (3970)	2160 (7090)
0.83 mm ² (AWG18)	1450 (4760)	1930 (6330)	3450 (11320)

m (ft.)

4 DETECTION AREA SETTING

You can adjust the detection area by 90 degrees in a horizontal direction and by 10 degrees in a vertical direction. Correct the vertical detection angle according to the mounting height of the sensor unit.

Applicable models

SIP-3020/5

SIP-4010/5

SIP-404/5

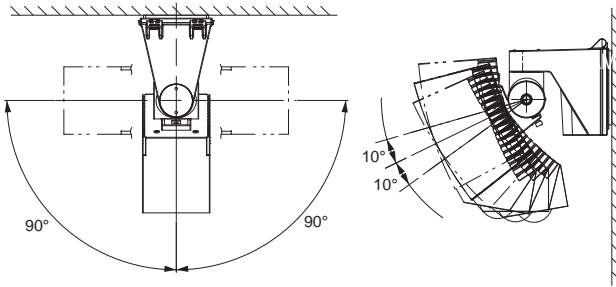

Cautions>>

To rotate the main unit counterclockwise, loosen the RH-side adjustment screw. To rotate the main unit clockwise, loosen the LH-side adjustment screw. Otherwise, you may find it difficult to tighten or you may find that you cannot tighten the adjustment screw when you are securing the main unit.

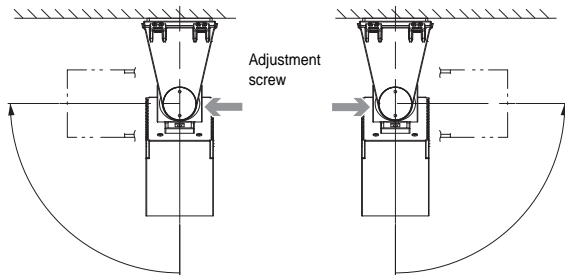

To rotate the unit counterclockwise

To rotate the unit clockwise

- (1) Adjust the angle of the main unit in a horizontal direction so that you can cover the desired detection area.

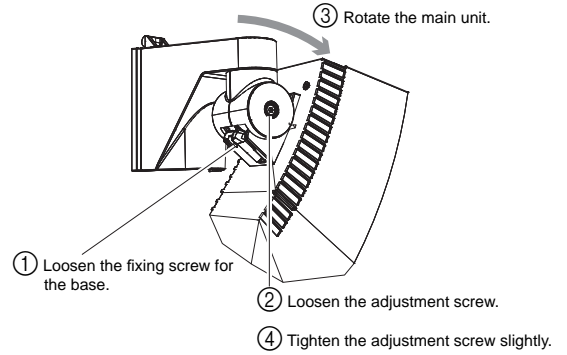

- (2) Adjust the angle of the main unit in a vertical direction so that you can cover the desired detection area.

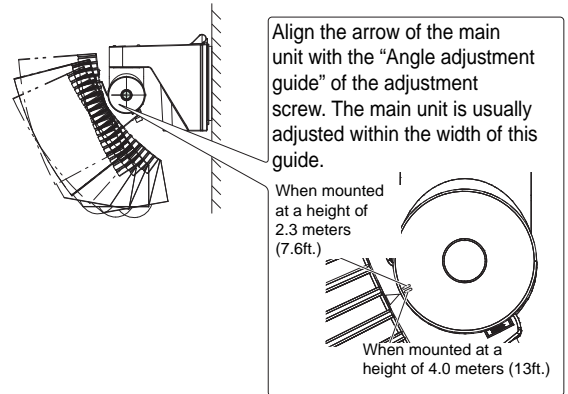

Cautions>>

If the mounting wall is at an angle, the arrow of the main unit may exceed the top or bottom limit of "Angle adjustment guide". Always check this using the area viewfinder or the walk tester. If the detection area is too high or too low, an object outside the detection area may be detected or incorrect object detection may occur.

- (3) Remove the cover.

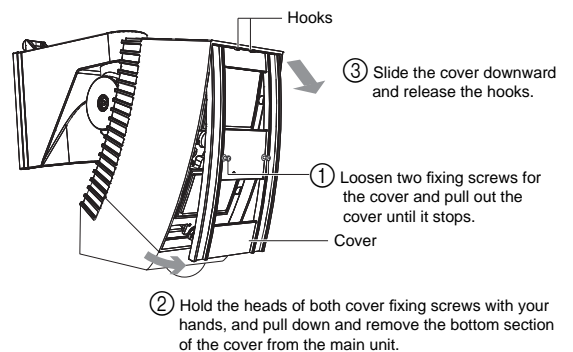

Cautions>>

The cover is linked to the main unit by nylon wire loop so that the cover does not fall. Do not pull the cover using excessive force.

(4) Mount the area viewfinder.

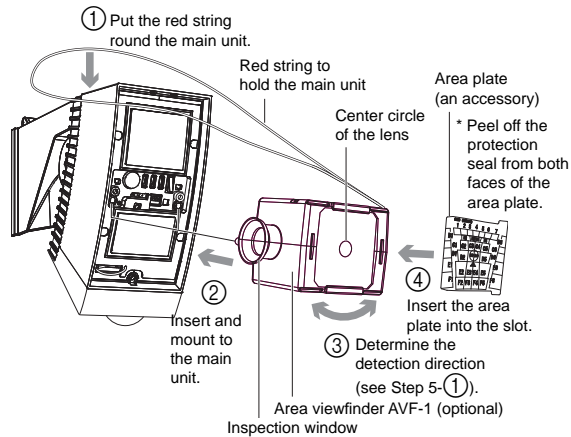

Mounting tips>>

- Engage the convex section of the area viewfinder fixing arms with the notches of the main unit, and insert and mount the arms.

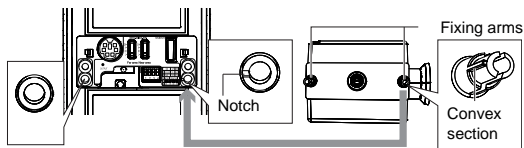

- Mount the area plate so that an arrow of the plate center section faces upward and the letter surface can be seen.
- Insert the area plate into the top and bottom grooves of the area viewfinder until the plate is stopped by the ribs.

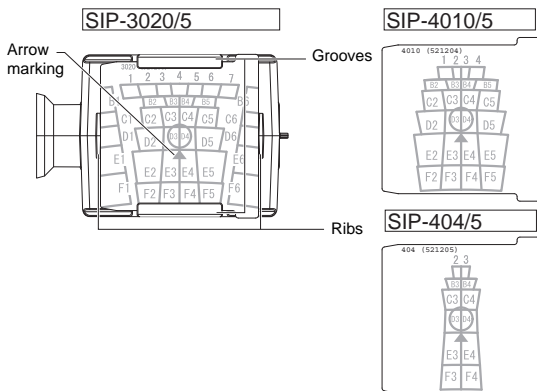

(5) Fine adjust the main unit angle in vertical and horizontal direction by observing the target area through the area viewfinder.

- To change the direction of the inspection window, rotate the area viewfinder in a horizontal direction until it clicks and stops.
- Move your face close to the viewfinder so that your eye comes within 5 mm of the inspection window (lens surface).

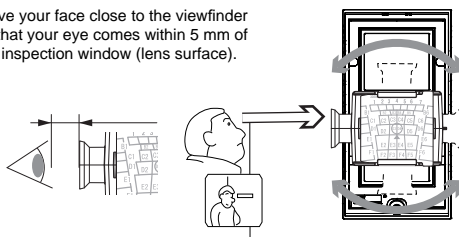

- Locate the center circle of the area plate on the center circle of the lens of the area viewfinder, and check the detection area pattern on the area plate and the background image.
 - * Each letter on the area plate corresponds to each mirror number (see Step 8-2).
 - * You cannot observe mirror numbers B1 to F1 and B6 to F6 (shown at right) of the SIP-3020 area plate through the inspection window. Check them using the walk tester.

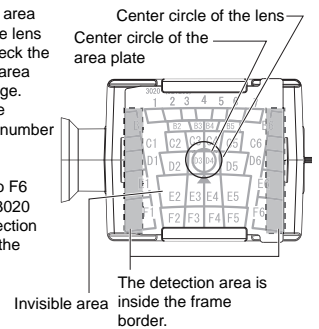

Adjusting tips>>

If you experience any of the following, see Step 11.

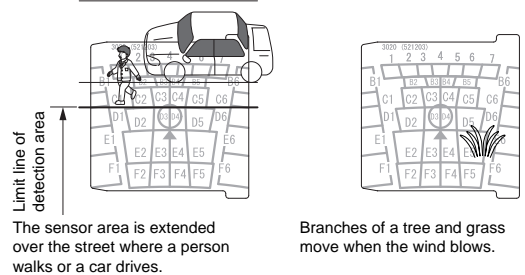

Cautions>>

- The area viewfinder is a supporting tool for detection area adjustment.
- After you have adjusted the detection area using the area viewfinder, always check the area using the walk tester.
- Never look directly into the sun through the area viewfinder.
- After you have used the area viewfinder, store it away from direct sunlight.

- Securely tighten the adjustment screw that you have loosened.

- Connect the walk tester (optional) to the sensor unit, and check that the detection area is correct.

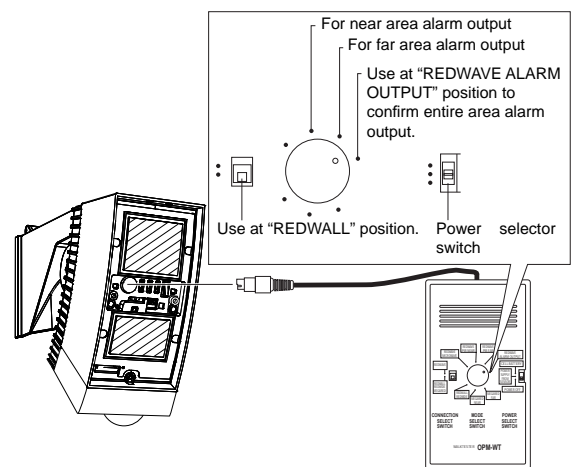

- When the power selector switch is turned to "POWER SUPPLY FROM SENSOR" position after plugging the cable into the walk tester connector, a continuous beeping sound will be heard.
- When a pedestrian first enters the detection area, the strong and weak beeps will sound alternately.
- When the entirety of a pedestrian's body is detected, the strong beep will sound continuously.

Cautions>>

When you are checking the detection area, take care not to cover the shaded area of the window with the walk tester or its cable. If infrared beams to the sensor are partially shielded, the detection sensitivity will drop and the detection operation may fail.

If it is difficult to detect an object>>

1. Set the detection logic switch to the "OR" position (see Step 5-2).
If the sensor is OK when you have completed the walk test, return the logic switch to the "AND" position.
2. Adjust the sensor sensitivity switch (see Step 5-1).

To mask the detection area>>

Detection area	How to mask the area	Reference
Far area	Use the switch.	5-3
	Use the masking plate (mounted in the main unit).	Step 7
Near area	Use the masking plate (mounted in the main unit).	8-1
	Attach the masking seal (an accessory) to the area mirror surface.	8-2

- Creep zone cannot be masked.

5 FUNCTION SETTING

Applicable models **SIP-3020/5 SIP-4010/5 SIP-404/5**

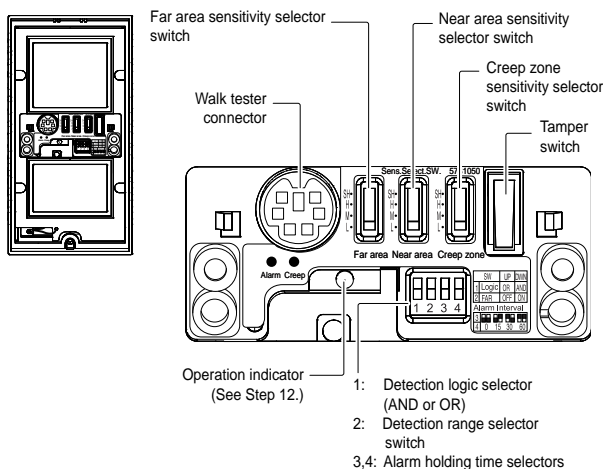

5-2 Detection Logic Selector Switch Dip switch 1

Applicable models **SIP-3020/5 SIP-4010/5 SIP-404/5**

The near area sensor has two dual-element devices, and it covers two types of plane areas alternately using the two devices.

SELECTOR POSITION	STATUS	FUNCTION
UP	OR (Factory default)	A sensor signal is output when an object is detected in either of the two detection areas. * Use this mode when you adjust the detection area. Switch to AND mode after you have finished the detection area adjustment.
DWN	AND	Use this mode to reduce instances of incorrect detection of objects. The sensor signal is output only when an object is detected within the two detection areas. If any objects are blocking multiple detection areas, use OR mode.

5-3 Detection Range Selector Switch Dip switch 2

Applicable models **SIP-3020/5 SIP-4010/5 SIP-404/5**

SELECTOR POSITION	STATUS	FUNCTION
UP	OFF	Cancels the far area detection. The detection area is reduced as shown below.
DWN	ON (Factory default)	Enables the far area detection.

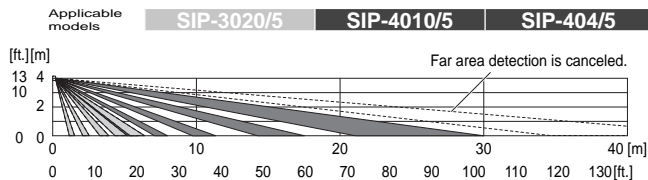
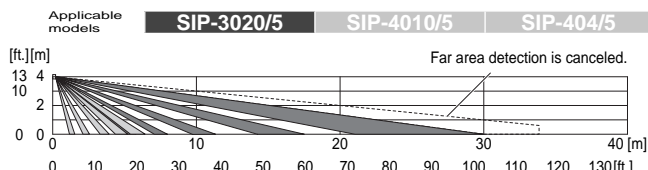

Cautions>>

If you cancel the far area detection, the detection distance is limited to approximately 20 meters (65ft.). Be sure to readjust and check the detection area using the area viewfinder and the walk tester.

5-1 Sensitivity Selector Switch for Near and Far Area

Applicable models **SIP-3020/5 SIP-4010/5 SIP-404/5**

You can change the sensitivity for far area detection and near area detection independently.

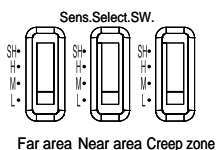

SELECTOR POSITION	FUNCTION
SH	Suitable for sites requiring a level of sensitivity higher than "H"
H	Suitable for sites requiring a level of sensitivity higher than "M"
M (Factory default)	Suitable for standard applications
L	Suitable for hostile and narrow area

5-4 Alarm Interval Switch Dip switch 3-4

Applicable models **SIP-3020/5 SIP-4010/5 SIP-404/5**

You can set an interval (4 different times) to suspend the alarm signal output. For example, if you set this interval to 30 seconds, no more alarm signals will be output for 30 seconds after the output of the first alarm signal. If no pedestrians are detected for more than 30 seconds, the system returns to the standby mode. Then, when a pedestrian is detected, the alarm signal will be output.

SELECTOR POSITION	FUNCTION
ON (Factory default)	0 sec
	15 sec
	30 sec
	60 sec

6 DETECTION AREA

Applicable models: **SIP-3020/5** SIP-4010/5 SIP-404/5

TOP VIEW (Installation height 4.0 m (13ft.))

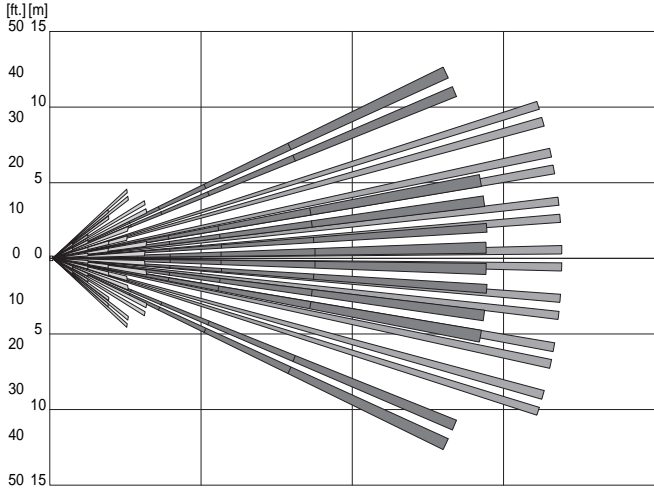

SIDE VIEW (Installation height 4.0 m (13ft.))

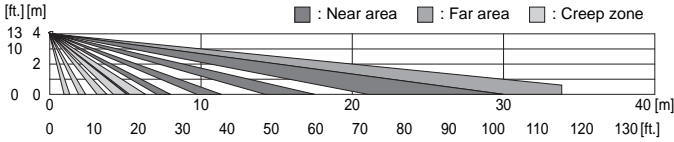

Applicable models: **SIP-3020/5** **SIP-4010/5** SIP-404/5

TOP VIEW (Installation height 4.0 m (13ft.))

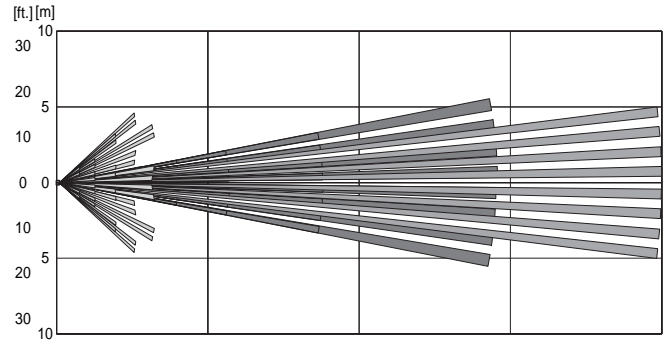

SIDE VIEW (Installation height 4.0 m (13ft.))

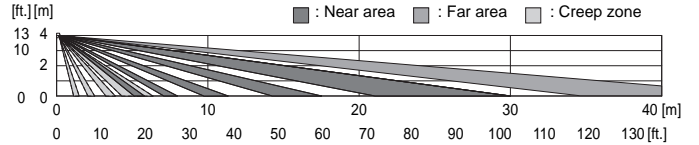

Applicable models: **SIP-3020/5** SIP-4010/5 **SIP-404/5**

TOP VIEW (Installation height 2.3 m (7.6ft.))

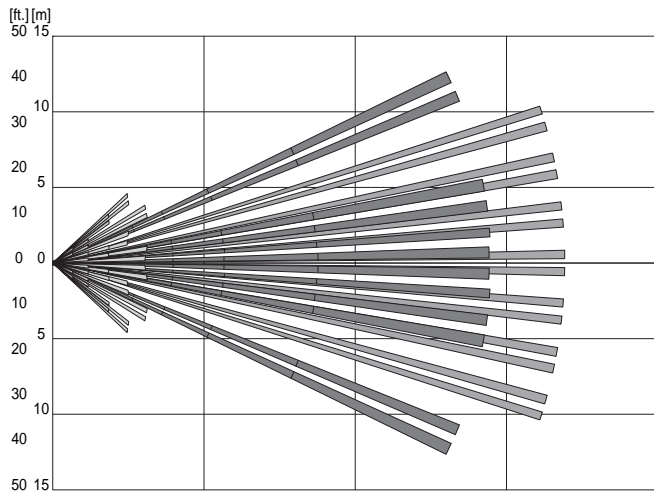

SIDE VIEW (Installation height 2.3 m (7.6ft.))

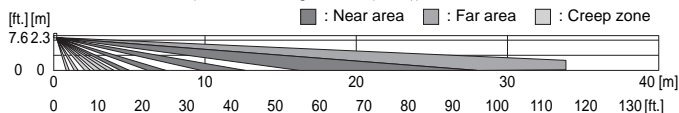

Applicable models: **SIP-3020/5** **SIP-4010/5** **SIP-404/5**

TOP VIEW (Installation height 2.3 m (7.6ft.))

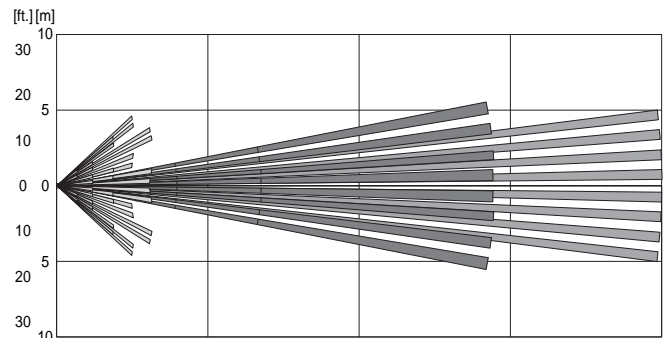

SIDE VIEW (Installation height 2.3 m (7.6ft.))

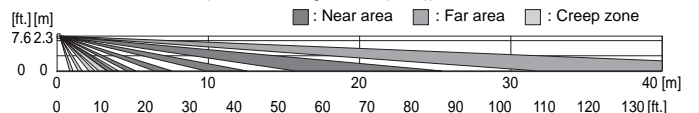

7 Masking the Far Area Sensor

Applicable models

SIP-3020/5

SIP-4010/5

SIP-404/5

TOP VIEW (Installation height 4.0 m (13ft.))

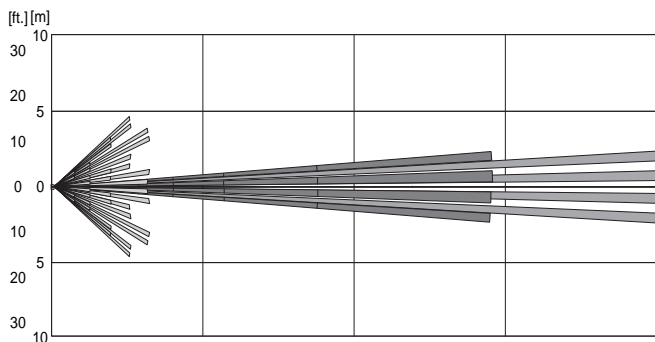

SIDE VIEW (Installation height 4.0 m (13ft.))

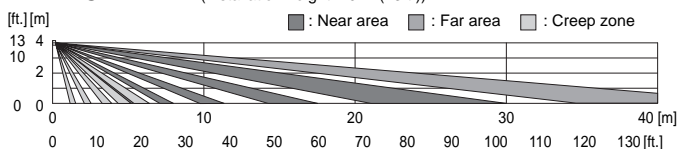

Applicable models

SIP-3020/5

SIP-4010/5

SIP-404/5

TOP VIEW (Installation height 2.3 m (7.6ft.))

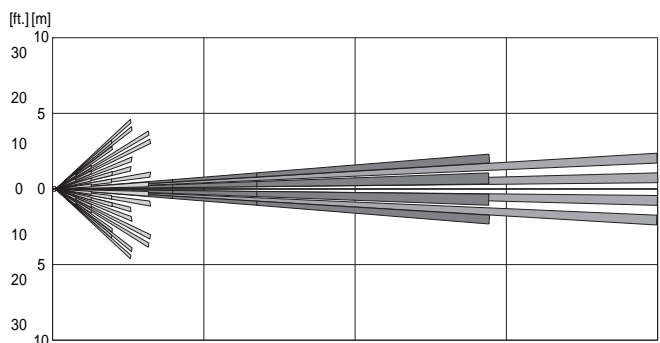

SIDE VIEW (Installation height 2.3 m (7.6ft.))

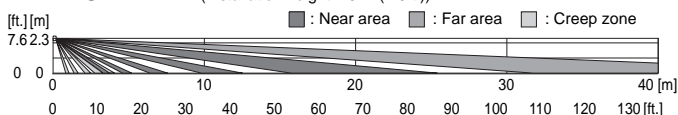

The far area mirror mounted in the main unit has 2 far masking plates; one at the right side of this mirror and the other at the left side of this mirror. You can mask the detection area by changing the position of these masking plates.

Cautions>>

- You can only mask the detection area from its outside to its inside using the masking plates. You cannot mask only the inside detection area.
- However, if you need to mask the inside detection area only, use the white space (margin) of the near area attaching a masking seal (an accessory) for the masking. Attach the seal and mask all mirrors that you need to shield.

Cautions>>

- The window is linked to the main unit by nylon wire loop so that the window does not fall. Do not pull the window using excessive force.
- After you have masked the detection areas, mount the window and place the excessive nylon wire loop inside the main unit.

How to remove the window>>

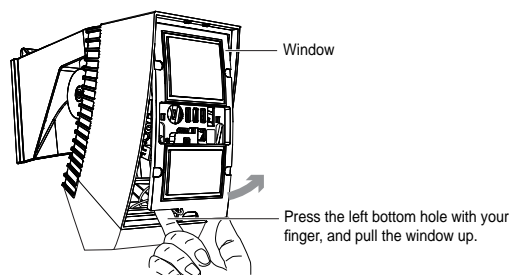

Applicable models

SIP-3020/5

SIP-4010/5

SIP-404/5

- 1 Remove the masking plate from the storage, and check the detection area and the mirror you use by referring to the area chart.

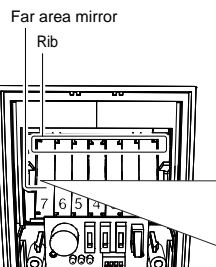

- 2 Attach the masking plate to the mirror, and secure it to the ribs.

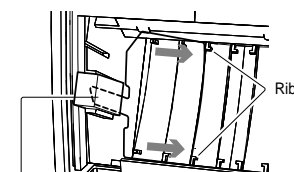

- 3 Insert the fixing rubber form to secure the knob of the masking plate.

50 40 30 20 10 0 10 20 30 40 50 [ft.]
15 10 5 0 5 10 15 [m]

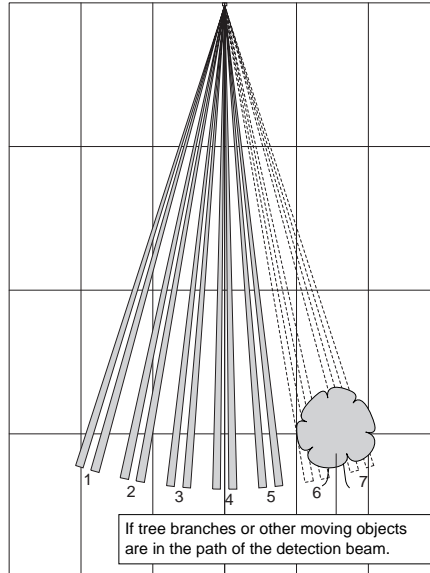

If tree branches or other moving objects are in the path of the detection beam.

8 MASKING THE NEAR AREA SENSOR

Applicable models

SIP-3020/5

SIP-4010/5

SIP-404/5

- 1 Remove the masking plate from the storage, and check the detection area and the mirror you use by referring to the area chart.

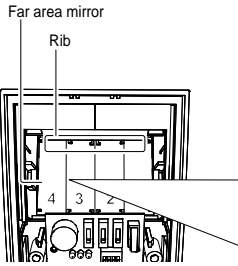

- 2 Attach the masking plate to the mirror, and secure it to the ribs.

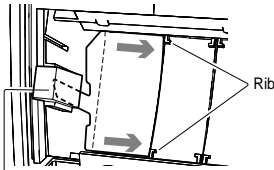

- 3 Insert the fixing rubber form to secure the knob of the masking plate.

SIP-4010/5

SIP-404/5

10 0 10 [ft.] 10 0 10 [ft.]
5 0 5 [m] 5 0 5 [m]

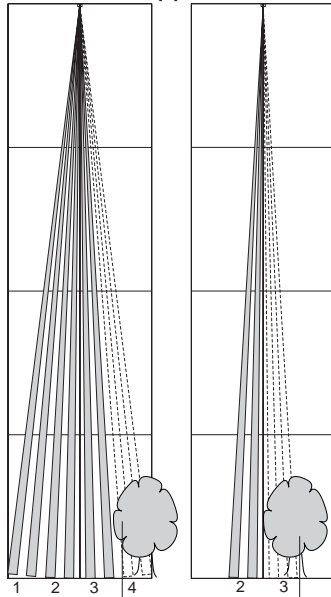

If tree branches or other moving objects are in the path of the detection beam.

8-1 Masking the Detection Areas using Masking Plates

The near area mirror mounted in the main unit has 2 near masking plates; one at the right side of this mirror and another at the left side of this mirror. You can mask the detection area by changing the position of these masking plates.

Cautions>>

You can mask the outside detection areas only; they are areas 1 and 6. Use the area masking seals (an accessory) to mask the other detection areas (see Step 8-2).

Applicable models

SIP-3020/5

SIP-4010/5

SIP-404/5

- 1 Remove the masking plate from the storage, and check the detection area and the mirror you use by referring to the area chart.

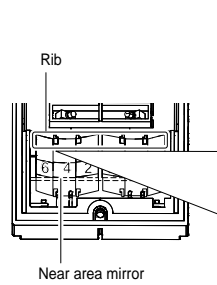

- 2 Attach the masking plate to the mirror, and secure it to the ribs.

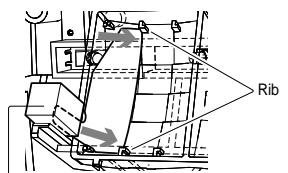

- 3 Insert the fixing rubber form to secure the knob of the masking plate.

50 40 30 20 10 0 10 20 30 40 50 [ft.]
15 10 5 0 5 10 15 [m]

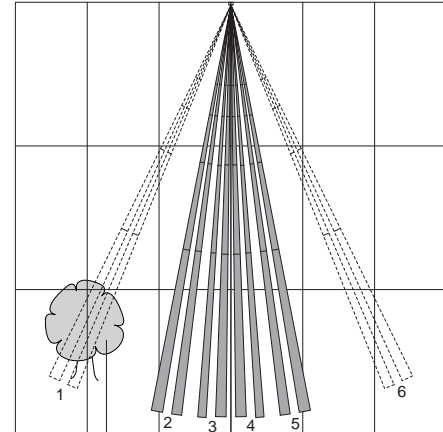

If tree branches or other moving objects are in the path of the detection beam.

9 ADJUSTING THE CREEP ZONE

8-2 Masking the Detection Areas using Masking Seals

Using the tweezers (an accessory), carefully attach the area masking seals (an accessory) to the near area mirror.

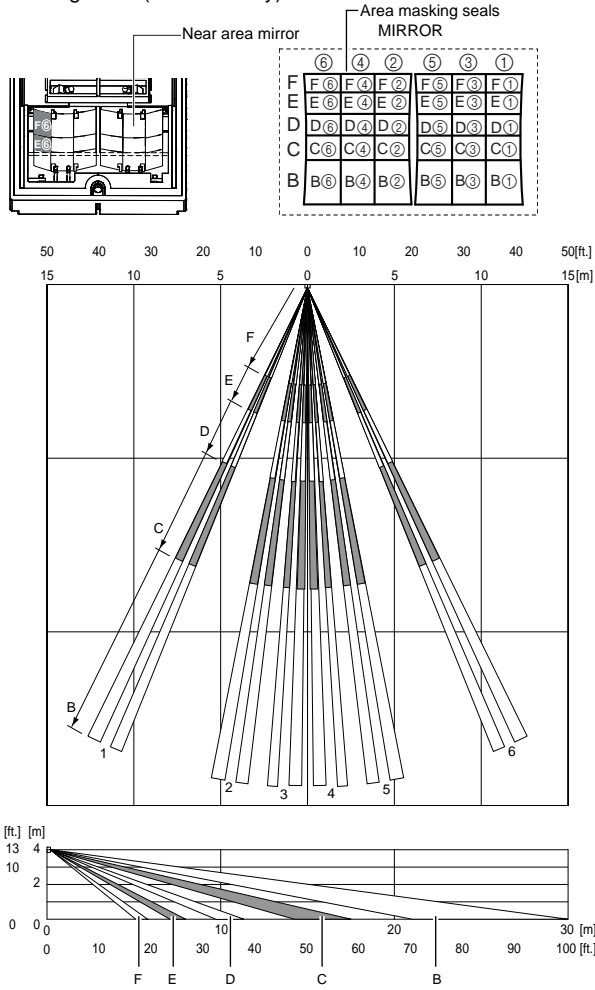

9-1 Adjusting the creep zone horizontally

The creep zone detection area can be adjusted between -90° and 90° horizontally.

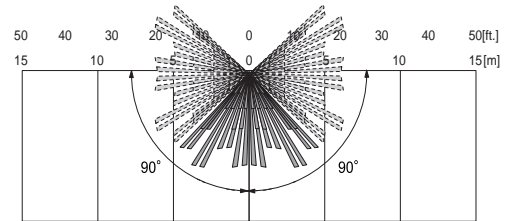
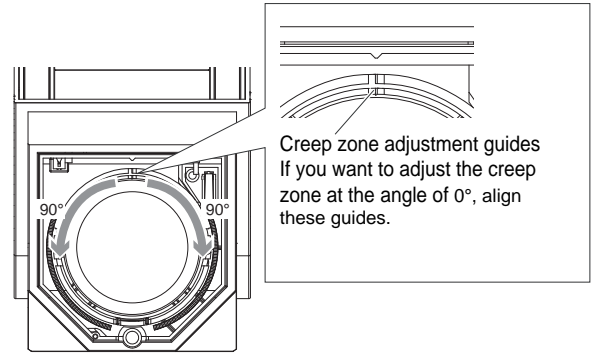

9-2 Adjusting the creep zone vertically

The creep zone detection area can be adjusted between -3° and 3° vertically.

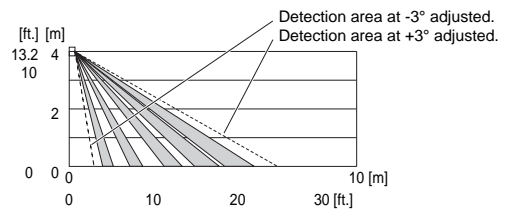
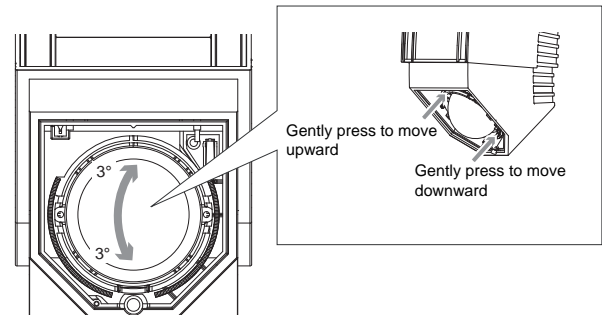

10 TERMINATION PROCEDURE

- (1) After you have adjusted all sensor items, securely tighten all adjustment screws that you have loosened. Finally, securely tighten the bottom fixing screws.

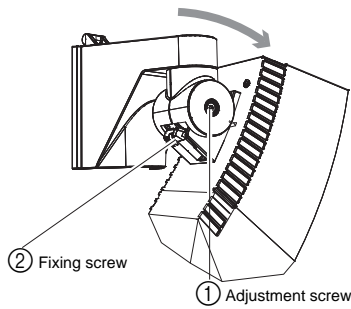

Cautions>>

- If you need to adjust the detection area again, be sure to loosen the fixing screw. If you try to move the main unit without loosening the fixing screw, the unit may be damaged.
- When you mount the cover, place the excessive nylon wire loop in the main unit. If the wire has been pinched by the window and the cover, rain drops may be able to enter into the main unit.

- (2) Mount the cover.

11 OPERATION TEST

11-1 If There is a Public Street Where a People Walk or Cars Drive by the Detection Area

Points>>

Reduce the size of the detection area so that it does not include any public streets.

- (1) Check to see that the arrow of the main unit is within the width of "Angle adjustment guide" on the adjustment screw.
- (2) Using the area viewfinder, check to see that the detection area does not include any public streets.
- (3) If the detection area does go beyond a public street, correct the vertical angle of the main unit. However, exercise care so that the arrow does not move away significantly from the "Angle adjustment guide" position.



If the arrow does move away significantly from the "Angle adjustment guide" position:

Mask the far area detection area using the masking plate or by using the far area masking switch. You may be required to also mask the near area detection area under specific sensor installation conditions (see Steps 5 and 8).

- (4) When a person walks along the street or a car drives along it, check the detection area using the walk tester.

Points>>

You cannot mount and use both the area viewfinder and walk tester simultaneously.

Cautions>>

The detection area may increase if there is a large difference in temperature between the moving object and the background.

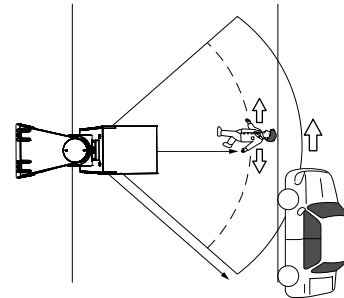

Cautions>>

A heat source beyond the detection area may cause a false alarm due to the reflection of heat off the ground. Examples of types of surfaces that reflect include water (puddles), wet roads, smooth concrete surfaces and asphalt roads.

If the source of the heat is strong and/or the reflection rate is high, the detection distance will be longer than required and may detect unnecessary objects beyond the target area. Therefore, select the detection range position according to the ground conditions of the installation site.

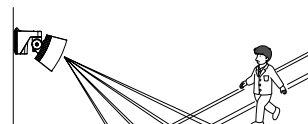

13 SPECIFICATIONS

11-2 If Tree Branches or Grass are Detected When They Move Within the Detection Area

Points>>

Adjust the detection area so that it does not cover tree branches or grass that move when the wind blows.

- (1) Check to see that the arrow of the main unit is within the width of "Angle adjustment guide" on the adjustment screw.
 - (2) Using the area viewfinder, check to see that the detection area does not cover tree branches or grass that may move when the wind blows.
 - (3) Use the walk tester to listen for sound level changes when there is no apparent activity in the detection area. Adjust the detection area so that it does not detect unwanted areas.
- ↓
- If the sound level changes, some part of the detection area must be active (i.e.: an object is moving).
- (4) Use the walk tester and locate the part of the detection area that is active. Change the walk tester selector switch position and determine whether the active part of the detection area is far or near.
 - (5) Using the area viewfinder again, locate the active detection area.
 - (6) Mask the active detection area. To do this, mask the area using the masking plate or the masking seal. Otherwise mask the area using the far area masking switch (see Steps 5, 7, and 8). Creep zone cannot be masked. Adjust the detection area again (see Steps 9).
 - (7) Using the walk tester again, check that the sound level changes. If the sound level does not change excessively, you can finish the adjustment.

Points>>

You cannot mount and use both the area viewfinder and the walk tester simultaneously.

12 LED FUNCTIONS

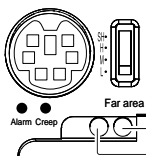

Creep zone operation indicator - Red LED
Far/near area operation indicator - Red LED

DETECTOR STATUS	If the cover is removed
During power ON	Blinks.
During standby	Turns OFF.
When detected (in far/near area)	Lights.
When detected (in creep zone)	Lights.

13-1 Specifications of the Main Unit

Applicable models

SIP-3020/5

SIP-4010/5

SIP-404/5

Model	SIP-3020/5	SIP-4010/5	SIP-404/5
Detection method	Passive infrared		
Detection area	30 x 20m (100 x 65ft.) wide	40 x 10m (130 x 33ft.) wide	40 x 4m (130 x 13ft.) narrow
Number of detection zones	74 zones	48 zones	24 zones
Mounting height	2.3 to 4m (7.6 to 13ft.)		
Power input	11 - 16V DC 22 - 26V AC		
Current draw	40mA max. (12V DC) 75mA max. (24V AC)		
Operation indicator	RED ALARM		
Warm-up period	Approx. 60 sec.		
Detection range	Far area: ON / OFF		
Alarm interval period	Off / 15 / 30 / 60 sec.		
Detection logic	AND/OR		
Tamper output	N.C. 28V DC, 0.1A max.		
Trouble output	N.C. 28V DC, 0.2A max.		
Alarm output	N.C.28V DC, 0.2A max. N.O.28V DC, 0.2A max.		
Sensitivity	SH / H / M / L		
Operating temperature	-25 to +60°C, -40 to +60°C with optional heating unit (-13 to +140°F, -40 to +140°F with optional heating unit)		
IP rating	Main unit :IP65 Chassis :IP55		
Dimensions (H x W x D)	247 x 102 x 264mm (9.7 x 4.0 x 10.4 in.)		
Weight	1.35kg (47.6 oz.)		
Accessories	Screws, paper template, allen key, area masking seal, tweezers, instruction manual, area plate, fixing rubber form		

DIMENSION

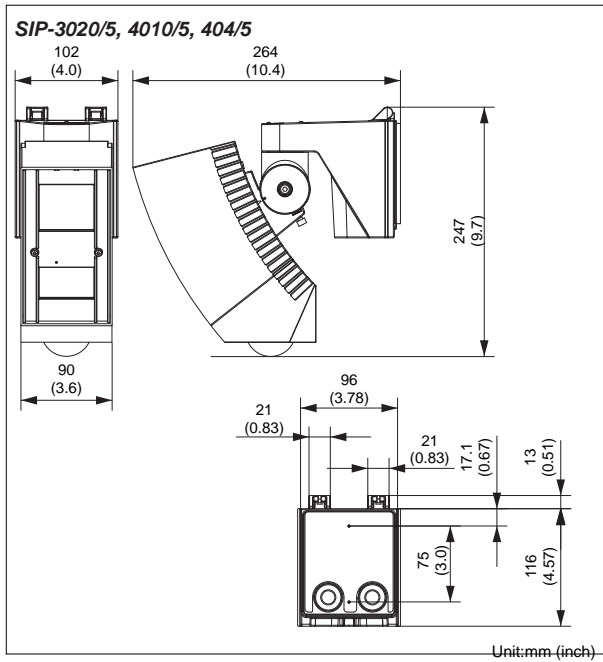

OPTION

- OPM-WT -Audio Walk Tester
- AVF-1 -Area View Finder
- SIP-MIDIHOOD -Sun/Snow shield
- SIP-HU -Heating unit

These units are designed to detect movement to activate CCTV system. Being only part of a complete surveillance system, we cannot accept responsibility for any damage or other consequences resulting from the activation of the unit.

Specifications and design are subject to change without prior notice.



OPTEX CO., LTD. (JAPAN)

(ISO 9001 Certified by LRQA) (ISO 14001 Certified by JET)

5-8-12 Ogoto Otsu Shiga 520-0101 JAPAN

TEL:+81-77-579-8670 FAX:+81-77-579-8190

URL:<http://www.optex.co.jp/e/>

OPTEX INCORPORATED (USA)

TEL:+1-909-993-5770

Tech:(800)966-7839

URL:<http://www.optexamerica.com>

OPTEX SECURITY SAS (FRANCE)

TEL:+33-437-55-50-50

URL:<http://www.optex-security.com>

OPTEX (EUROPE) LTD. (UK)

TEL:+44-1628-631000

URL:<http://www.optex-europe.com>

OPTEX SECURITY Sp.z o.o. (POLAND)

TEL:+48-22-598-06-55

URL:<http://www.optex.com.pl>