

Client:

Date:

 / /

Delivery desired date:

 / /

01. INSTALLATION AREA

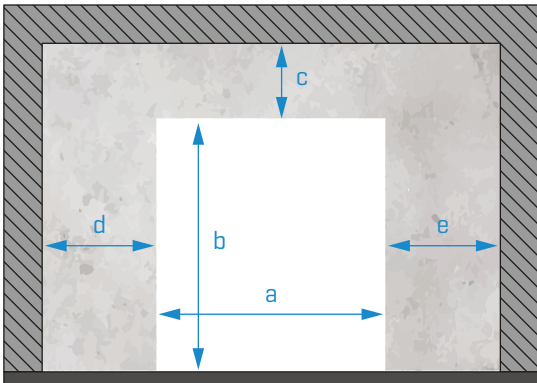

Quantity



Local dimensions [mm]:



MANDATORY FILLING



a

b

c

d

e

PVC color:



5013

6026

1003

7037

9016

5002

3002

1015

7038

5015

2004

9005

7035

Other:

Additional devices:



Magnetic loop

Model

Radars

Model

Remote control

Tunnel kit

STANDARD COLOR - RAL9010

Textured finishing

OTHER COLORS / FINISHINGS

If you wish another color or type of finishing:

Other Options:



OBSERVATIONS:



IN THIS SPACE YOU SHOULD DESCRIBE EVERYTHING YOU FIND RELEVANT TO THE AUTOMATISM PRODUCTION]

MOTOR AND CONTROL BOARD POSITION:

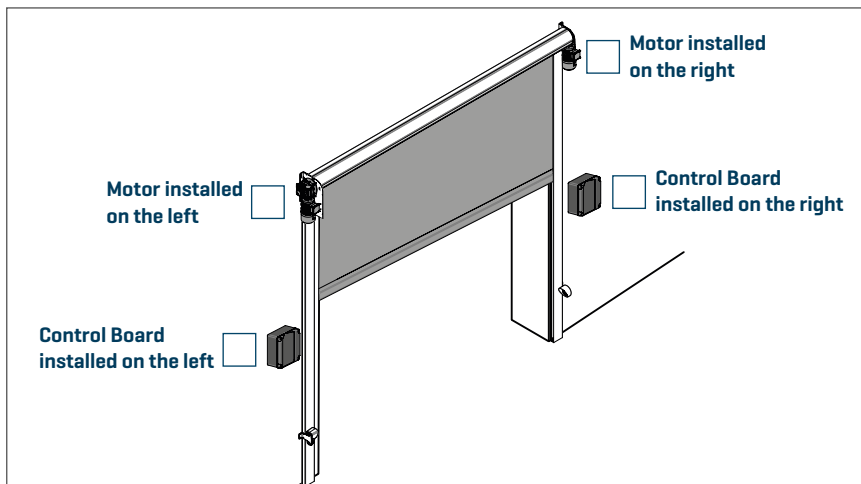

IN THIS SPACE YOU SHOULD DRAW EVERYTHING YOU FIND RELEVANT TO THE AUTOMATISM PRODUCTION]



02. TECHNICAL DRAWING [DOORS UP TO 3500mm WIDTH AND/OR HEIGHT]

Dimensions in mm

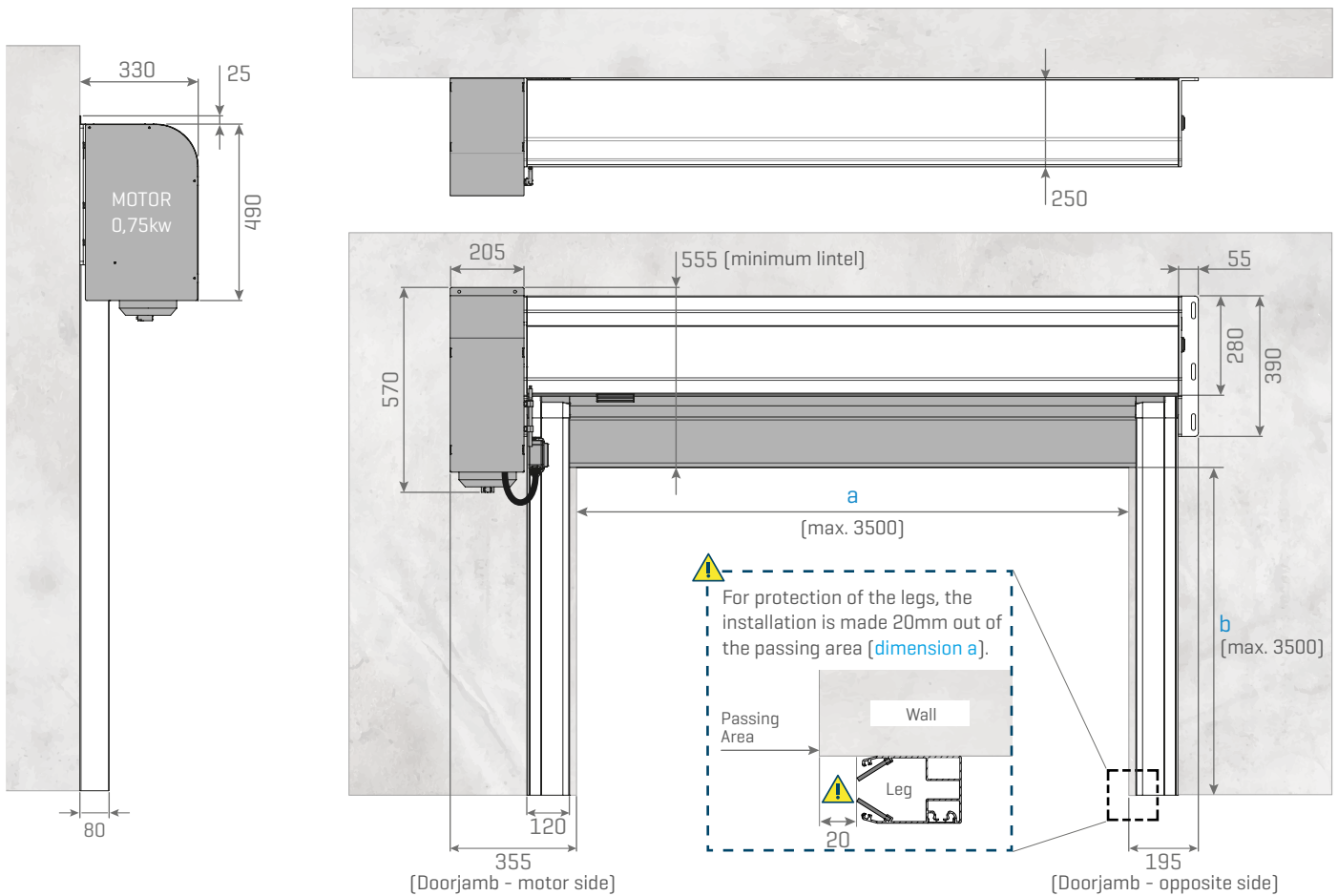

02. TECHNICAL DRAWING [DOORS OVER 3500mm WIDTH AND/OR HEIGHT]

Dimensions in mm

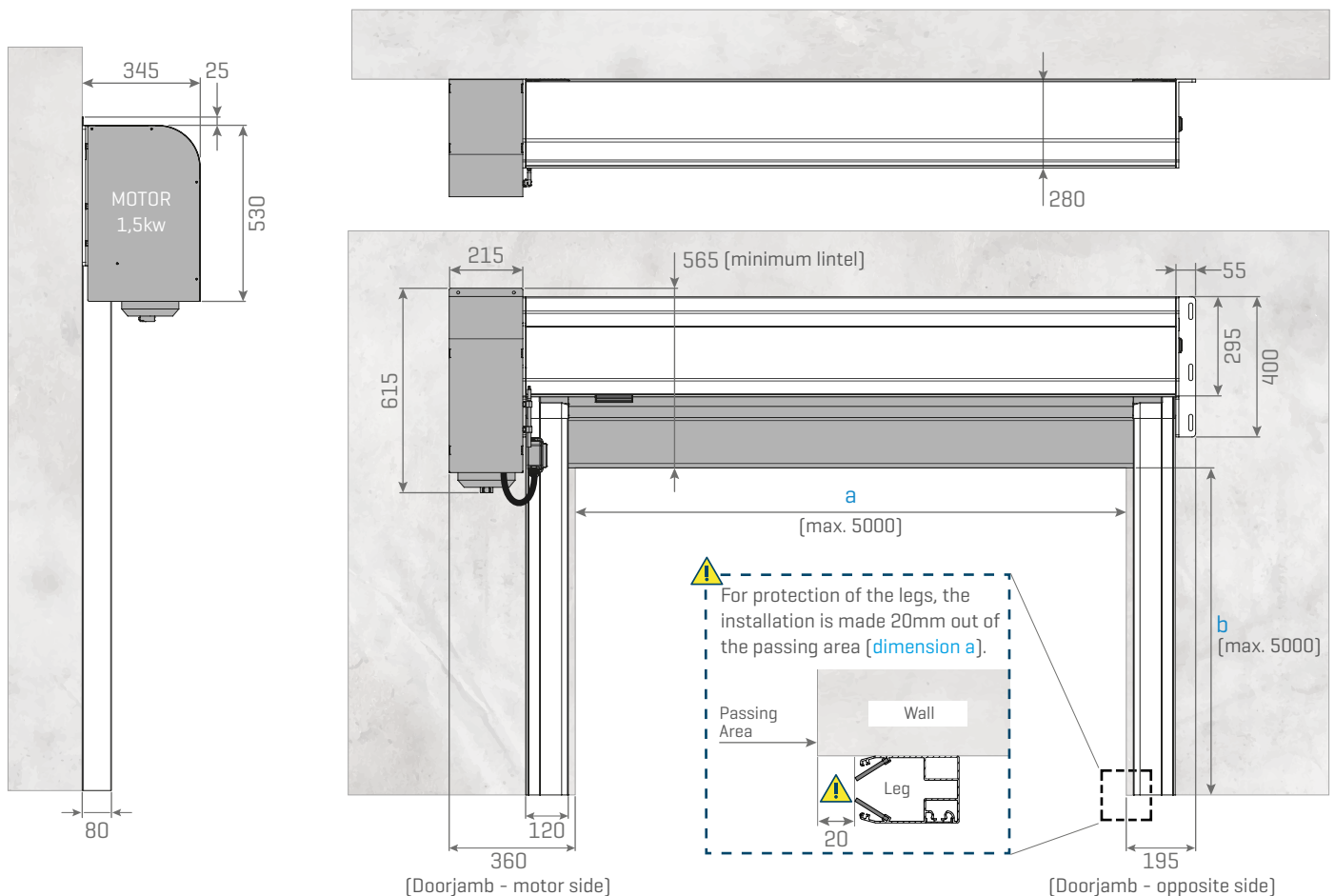

04. TECHNICAL DRAWING - TUNNEL KIT (DOORS UP TO 3500mm WIDTH AND/OR HEIGHT)

Dimensions in mm

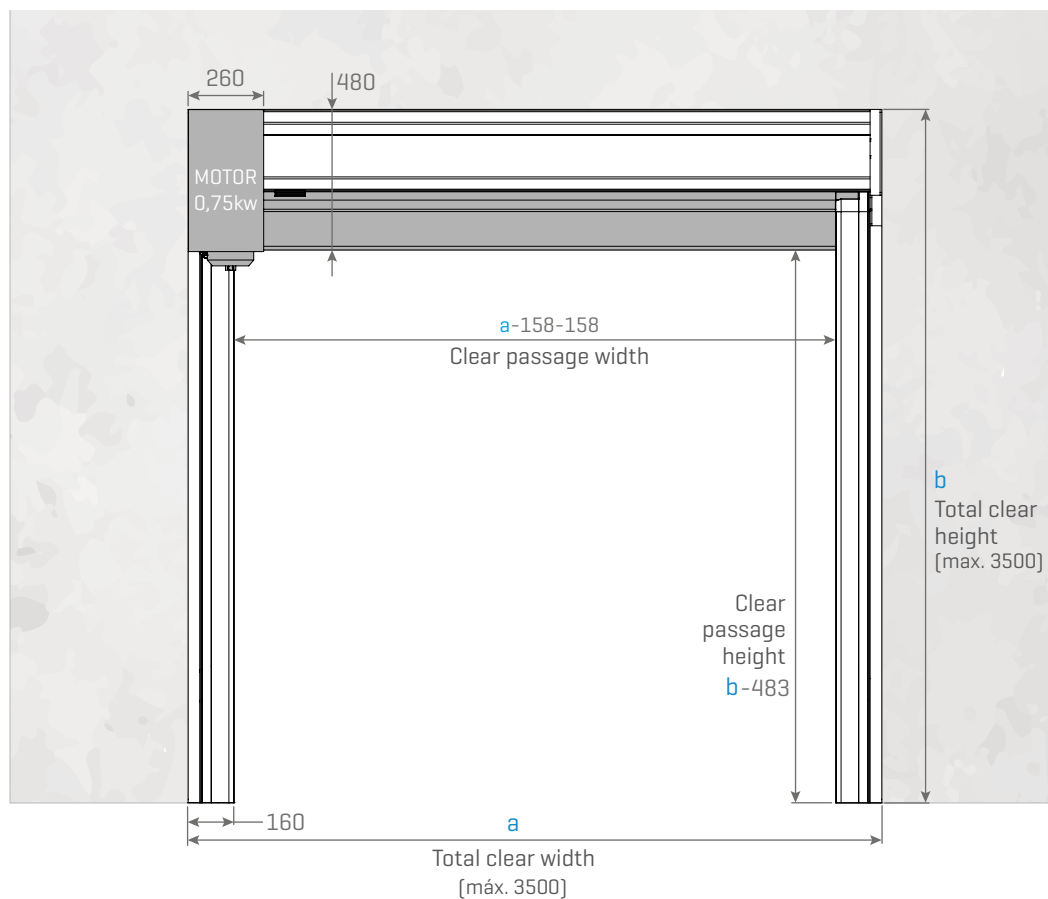
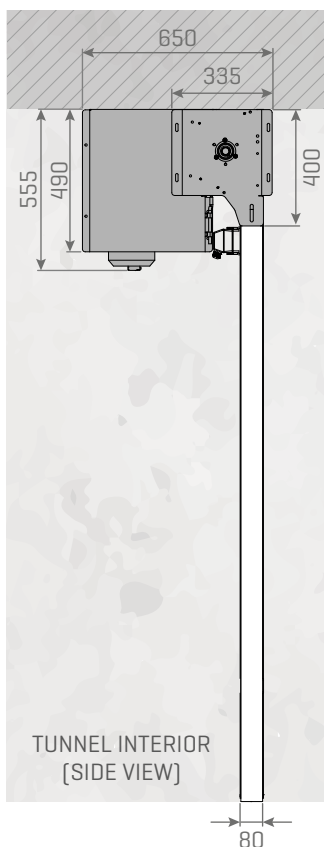

05. TECHNICAL DRAWING - TUNNEL KIT (DOORS OVER 3500mm WIDTH AND/OR HEIGHT)

Dimensions in mm

