

DORCAS-50N305-424

Incuietoare electromagnetica incastrata cu monitorizare

Imagine



Descriere

DORCAS-50N305-424 este o incuietoare electromagnetica de tip strike, fail secure, cu monitorizare (NO/NC/COM). Avand o forta de retinere de 800kgf, este ideala pentru montarea pe usi grele.

Caracteristici

•Functionare:	Normala (se deschide la alimentare)
•Limba ajustabila:	Da
•Simetrica:	Da
•Zavor radial:	Nu
•Memorie mecanica:	Nu
•Rezistent la apa:	Nu
•Rezistent la foc:	Nu
•Monitorizare:	Da(NO/NC/COM)
•Aplicabilitate:	Usi grele, trafic intens
•Suport compatibil:	EZR-25, EZH-25, EZH-4C, GX-INOX F101-L, F102-R, GU-L, GU-R

Specificatii

•Tensiune de alimentare:	24V DC
•Curent absorbit:	120mA
•Rezistenta:	230 Ohm
•Fora de retinere:	7800 N/ 800kg-f
•Durata de viata:	500.000 de deschideri
•Temperatura:	-15°C ~ +40°C
•Dimensiuni:	75(H) x 21(L) x 28(A)mm
•Masa bruta:	0,22 kg

Dimensiuni

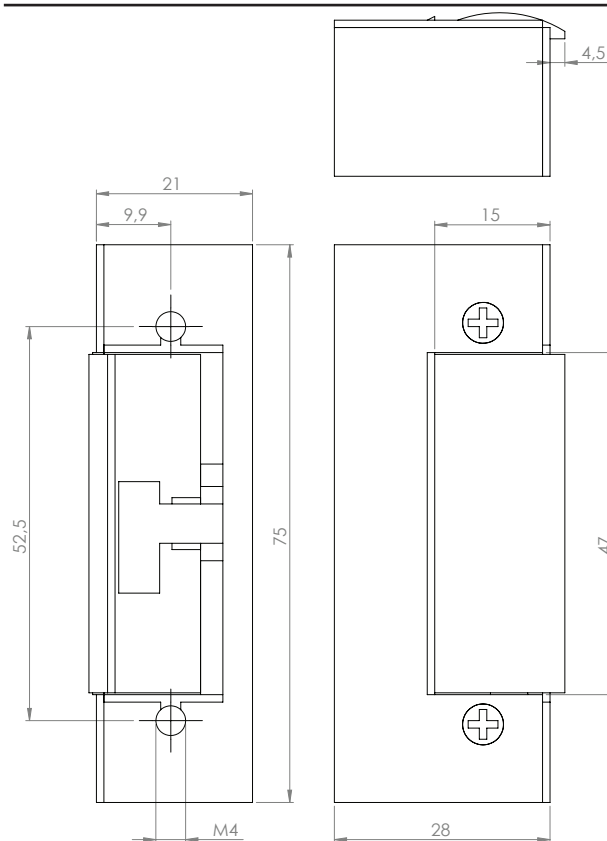

Schita de montaj

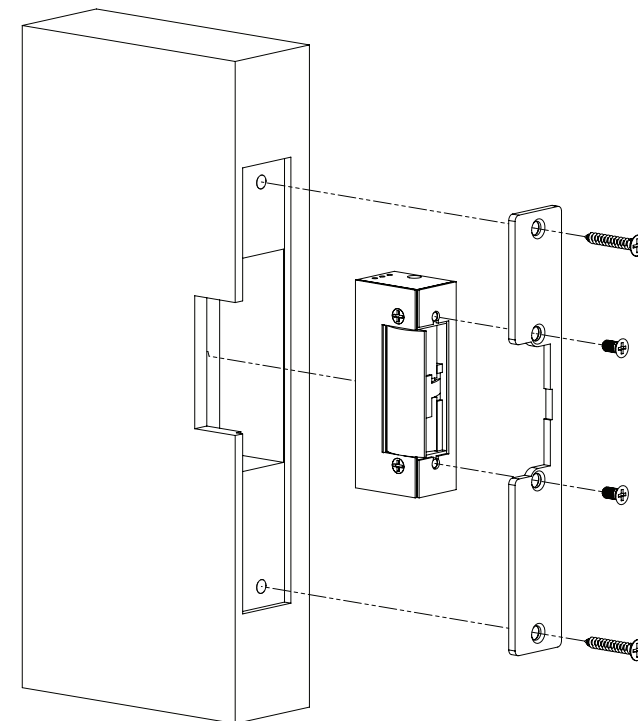

Observatii



EEE FAC OBIECTUL UNEI
COLECTARI SEPARATE