

PRODUCT DATASHEET

SG350-IS

WIRELESS INTRINSICALLY SAFE HEAT DETECTOR

The SG350-IS Intrinsically Safe Wireless Optical Heat Detector is a fully intelligent device which is compatible with all of the Argus Wireless Translator and Expander Modules and has been approved for use in Category 1, 2 or 3 hazardous atmospheres. Its fully wireless capability means it requires no special wiring or barriers making installation quick, safe and cost effective. The Argus range of wireless detectors are third party approved to EN54 and utilise the latest cutting edge technologies and features. The well proven adaptive radio signal processing algorithms combined with the latest detector design ensure the highest levels of life safety and system reliability.

Important Note: Translators/Expanders must be sited in safe areas. Refer to Argus Security Application Guide for IS Wireless Devices to aid safe implementation.



KEY FEATURES

- ATEX & IECEx Type Approved
- ATEX Code: Ex II 1G
- Classification: Ex ia IIC T4 Ga (-10°C ≤ Ta ≤ +55°C)
- Bi-directional wireless communication
- Certified to EN54
- Up to 3 year battery life
- 5 year product warranty
- Uses standard low cost lithium battery
- Quick and safe installation

TECHNICAL INFORMATION

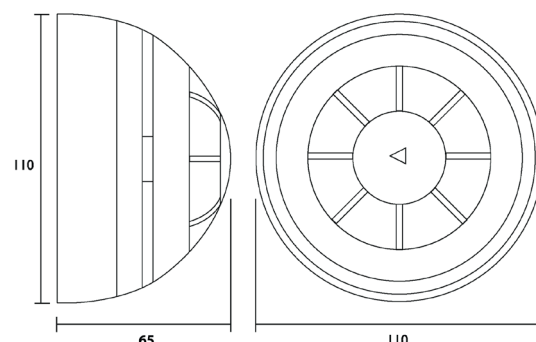

TECHNICAL SPECIFICATION

- | | |
|--|-------------------------|
| ■ Operating frequency range | 868 – 870 MHz |
| ■ Max radiated power | 5dBm (3mW) |
| ■ Operating channels | Multiple |
| ■ Dimensions | 110mm x 65mm |
| ■ Primary battery | CR123A (3 V & 1.2 Ah) |
| ■ Secondary battery | CR2032A (3 V & 0.24 Ah) |
| ■ Weight (without batteries) | 190g |
| ■ Operating Temperature (no icing) | -10°C to +55°C |
| ■ Max humidity (non condensing) | 95% RH |
| ■ IP rating | 40 |
| ■ Primary battery lifespan (typical) | 3 years |
| ■ Secondary battery lifespan (typical) | 2 months |

STANDARDS & APPROVALS

- BS EN 54-5: Heat Detectors - Point Detectors
- BS EN 54-25: Components using radio links and system requirements



Baseefa16ATEX0111X



Note: Certified device performance may vary depending on the approval body.

PRODUCT DATASHEET : SG350-IS

CERTIFICATION REQUIREMENTS

- IEC 60079-0:2011 / EN 60079-0:2012+A11:2013
- IEC 60079-11:2011 / EN 60079-11:2012
- IEC 60079-28:2015 / EN 60079-28:2015

SYSTEM DESIGN

Example of Wireless System Design Using Ex IS Certified Devices

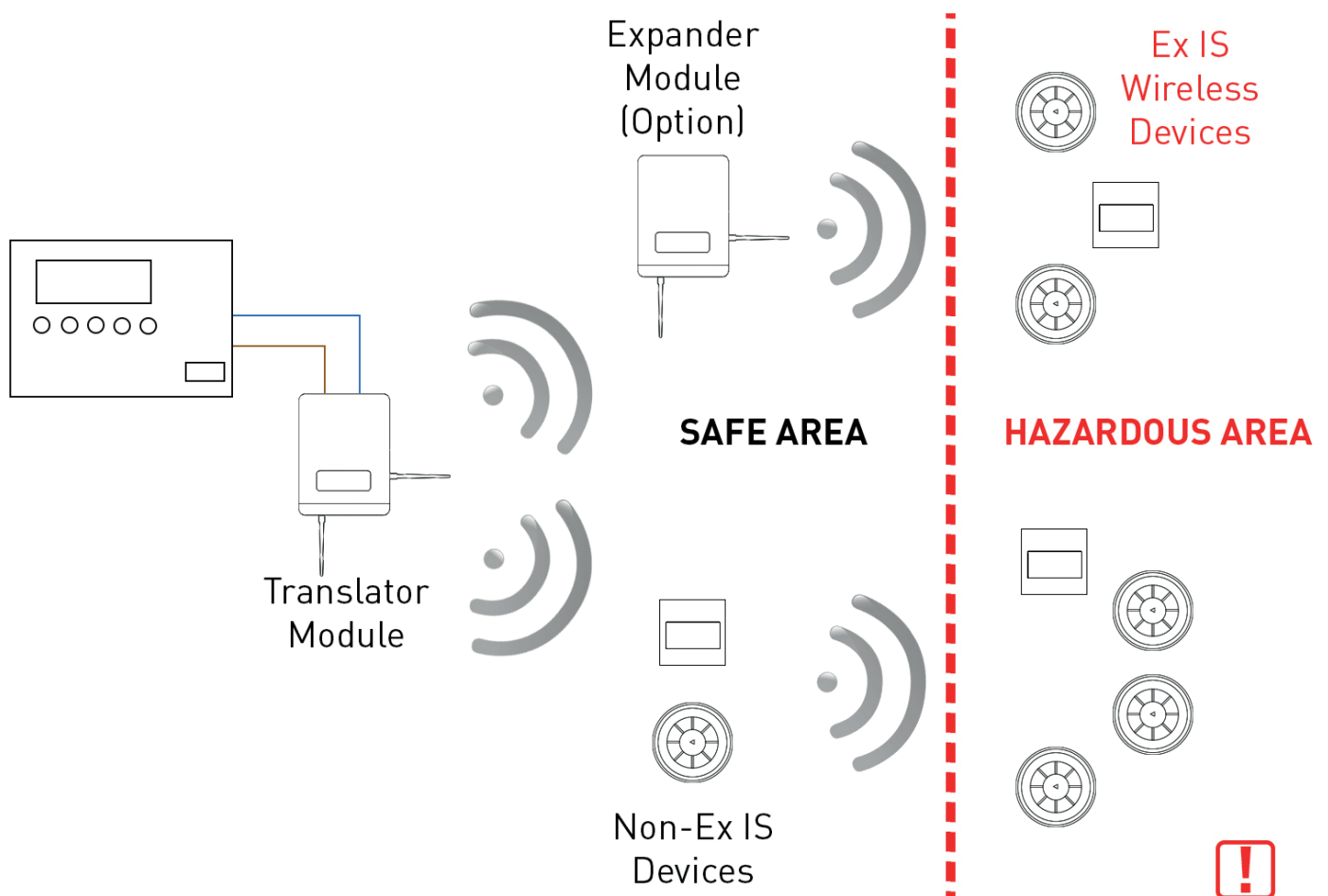

PRODUCT DATASHEET : SG350-IS

LED INDICATION

The device is equipped with a tri-colour LED (red/green/amber) that provides visual indication for functional conditions and battery levels as indicated in the sections below:

OPERATIONAL STATUS INDICATIONS

Status	Amber LED	Green LED	Red LED
Switching in to operating mode		Short flashes	-
Switching in to programming mode	-	-	4 short flashes
Self-adjustment mode	-	-	1 Second On & 0.1 Second Off
Normal condition	-	-	-
Alarm condition	-	-	0.5 Second On & 0.5 Second Off
Program failure	-	-	On Constantly
Main battery fault	-	-	0.1 Second On & 5 Seconds Off
Secondary battery fault	-	0.1 Second On & 5 Seconds Off	-
Both batteries fault	-	-	Sequential bi-colour flashing
Loss of radio link with Translator/ Expander	0.5 Second On & 2 Seconds Off	-	-

COMMUNICATION QUALITY ASSESSMENT

It is possible to assess the wireless communication quality between the device and translator or expander using the built in test facility. After successful programming of the device, changing the "Program" switch to the "ON" position will set the device into test mode and the LED will start blinking according to the table below:

Communication Quality (dB)	Level	Green LED	Red LED
No connection	Fail - 0 - No Connection	-	Two flashes
Link margin is less than 10 dB	Fail - 2 - Very Poor	-	One flash
Communication with link margin from 10 dB to 20 dB	Fail - 3 - Poor	One flash	
Robust communication with link margin over 20 dB	Pass - 4	Two flashes	

Note: The "program" switch must be returned to the 1 position for normal device operation